

W6D910-GB01-01

AC axial fan - HyBlade®

sickled blades (S series)

with full square nozzle

ASIA PACIFIC SHENGRUI LIMITED

Phone +00852 56261528

info@apacfan.com

www.apacfan.com

Limited partnership · Headquarters Mulfingen
County court Stuttgart · HRA 590344

General partner Elektrobau Mulfingen GmbH · Headquarters Mulfingen
County court Stuttgart · HRB 590142



Nominal data

Type	W6D910-GB01-01		
Motor	M6D138-NA		
Phase		3~	3~
Nominal voltage	VAC	400	400
Connection		Δ	Y
Frequency	Hz	50	50
Type of data definition		ml	ml
Valid for approval / standard		CE	CE
Speed	min ⁻¹	920	760
Power input	W	2020	1390
Current draw	A	4.62	2.6
Max. back pressure	Pa	160	105
Max. ambient temperature	°C	60	60
Starting current	A	18.6	6.2

ml = max. load · me = max. efficiency · fa = running at free air · cs = customer specs · cu = customer unit
Subject to alterations

Data according to ErP directive

		Actual	Request 2013	Request 2015
Installation category	A			
Efficiency category	Static			
Variable speed drive	No			
Specific ratio*	1.00			
Overall efficiency η_{es}		38.4	31.5	35.5
Efficiency grade N		42.9	36	40
Power input P_e	kW	1.96		
Air flow q_v	m ³ /h	18720		
Pressure increase p_{fs}	Pa	145		
Speed n	min ⁻¹	925		

Data established at point of optimum efficiency

* Specific ratio = $1 + p_b / 100\,000\text{ Pa}$



ebmpapst

W6D910-GB01-01

AC axial fan - HyBlade®

sickled blades (S series)

with full square nozzle

Technical features

Mass	52.4 kg
Size	910 mm
Surface of rotor	Cast in aluminium
Material of terminal box	PP plastic
Material of blades	Aluminium sheet insert, sprayed with PP plastic
Material of wall ring	Sheet steel, pre-galvanised and coated in black plastic (RAL 9005)
Material of guard grille	Steel, coated in black plastic (RAL9005)
Number of blades	5
Blade angle	-5°
Direction of air flow	"V"
Direction of rotation	Clockwise, seen on rotor
Type of protection	IP 54
Insulation class	"F"
Humidity class	F3-1
Max. permissible ambient motor temp. (transp./ storage)	+ 80 °C
Min. permissible ambient motor temp. (transp./storage)	- 40 °C
Mounting position	Any
Condensate discharge holes	On rotor and stator sides
Operation mode	S1
Motor bearing	Ball bearing
Touch current acc. IEC 60990 (measuring network Fig. 4, TN system)	<= 3.5 mA
Electrical leads	Via terminal box
Motor protection	Thermal overload protector (TOP) brought out
Cable exit	Axial
Protection class	I (if protective earth is connected by customer)
Product conforming to standard	EN 60034; EN 61800-5-1; CE
Approval	VDE



W6D910-GB01-01

AC axial fan - HyBlade®

sickled blades (S series)

with full square nozzle

Product drawing

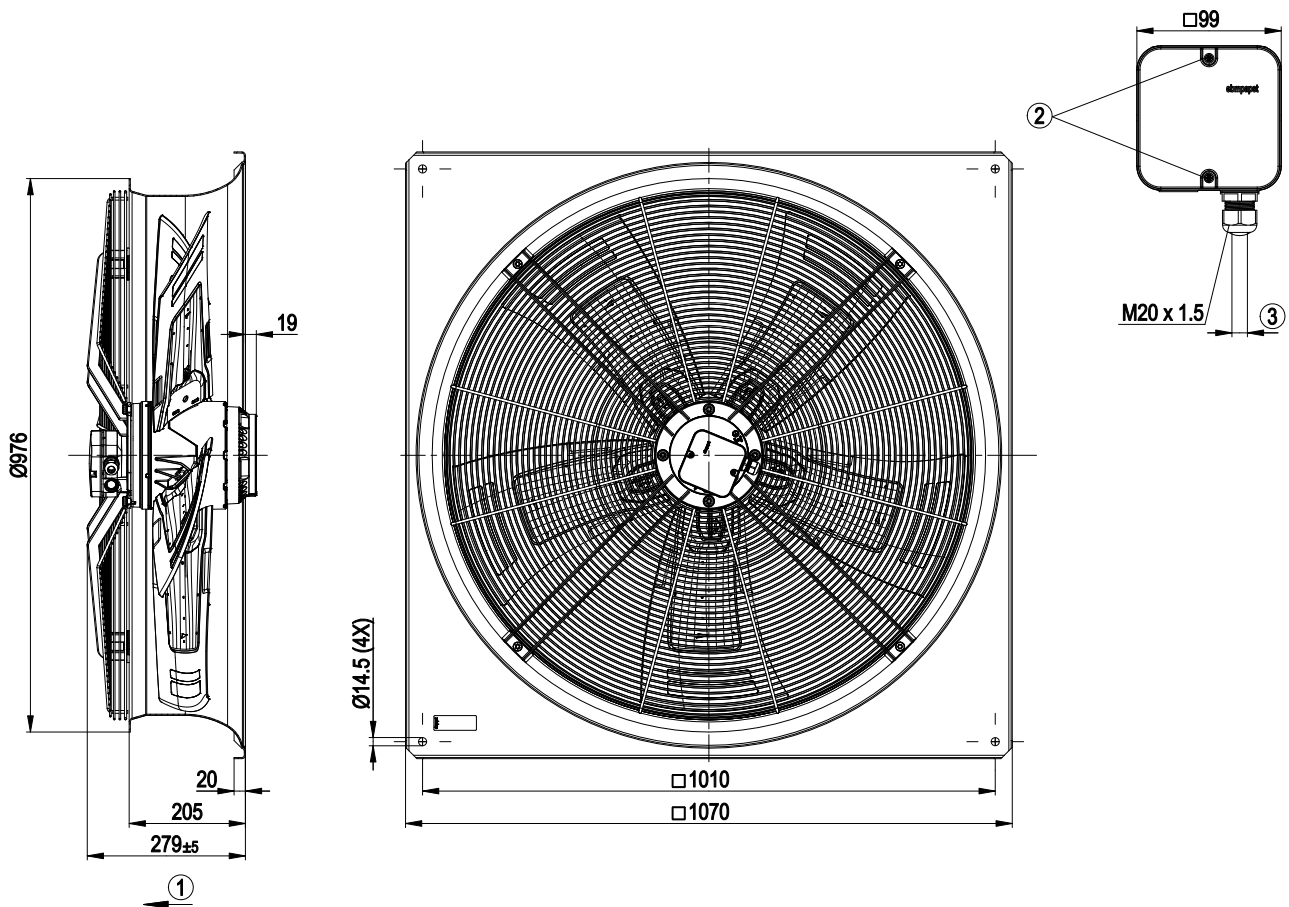

1	Direction of air flow "V"
2	Tightening torque 1.5 ± 0.2 Nm
3	Cable diameter: min. 7 mm, max. 14 mm; tightening torque: 2 ± 0.3 Nm



AC axial fan - HyBlade®

sickled blades (S series)

with full square nozzle

Connection screen

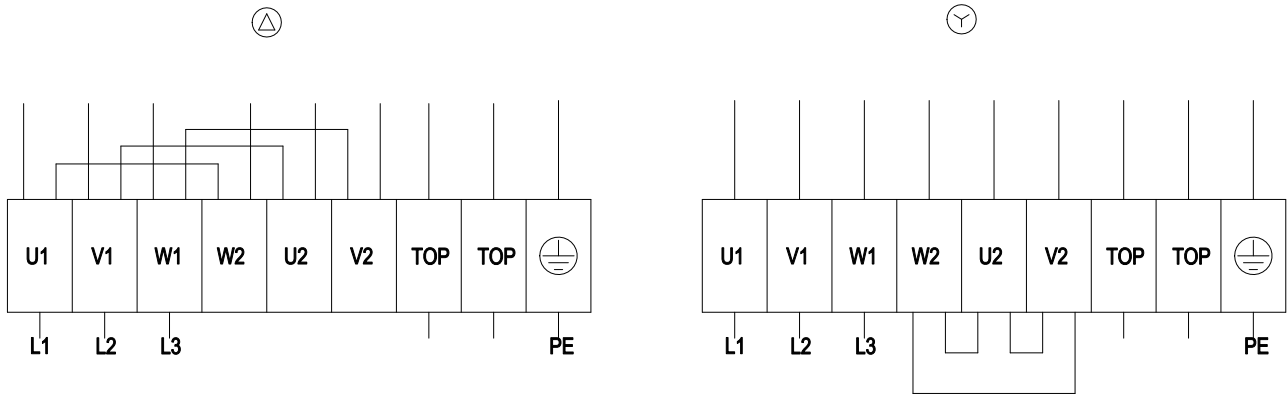

Δ	Delta connection	Y	Star connection	L1	= U1 = black
L2	= V1 = blue	L3	= W1 = brown	W2	yellow
U2	green	V2	white	TOP	2 x grey
PE	green/yellow				

Charts: Air flow 50 Hz

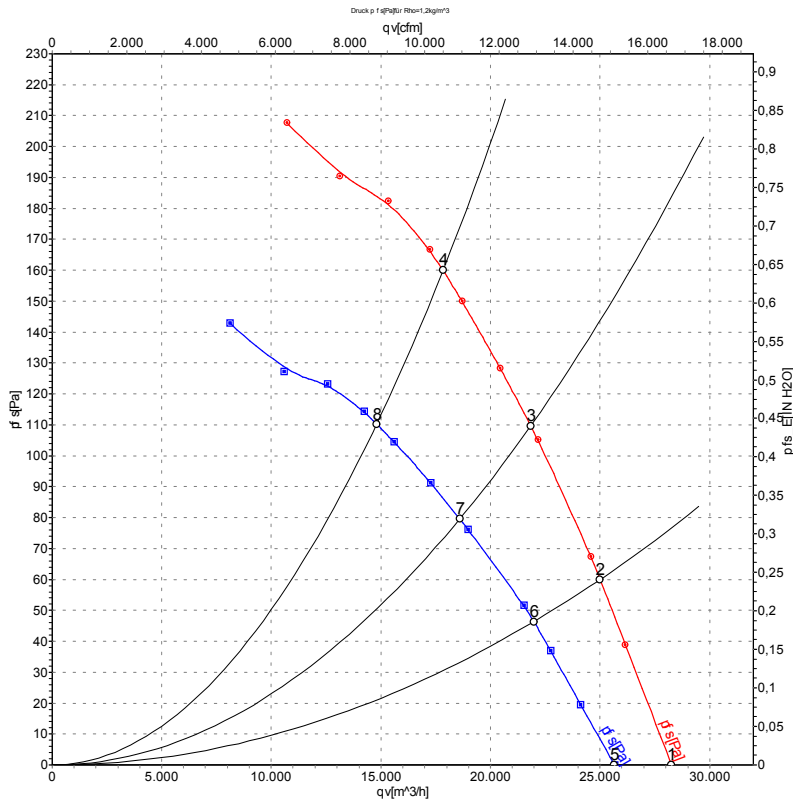

Measurement: LU-117505
Measurement: LU-119168

Air performance measured as per ISO 5801 Installation category A. For detailed information on the measuring set-up, please contact ebm-papst. Suction-side noise levels: LwA measured as per ISO 13347 / LpA measured with 1m distance to fan axis. The values given are valid under the measuring conditions mentioned above and may vary according to the actual installation situation. With any deviation from the standard set-up, the specific values have to be checked and reviewed with the unit installed.

Measured values

	Conn.	U	f	n	P _e	I	LpA _{in}	LwA _{in}	LwA _{out}	qv	p _{fs}
		V	Hz	min ⁻¹	W	A	dB(A)	dB(A)	dB(A)	m³/h	Pa
1	Δ	400	50	955	1288	3.97	72	79	79	28260	0
2	Δ	400	50	940	1577	4.18	69	77	76	25000	60
3	Δ	400	50	930	1800	4.40	69	76	76	21830	110
4	Δ	400	50	920	2020	4.62	72	79	78	17840	160
5	Y	400	50	865	1000	1.88	69	76	76	25660	0
6	Y	400	50	825	1186	2.18	66	73	73	21980	46
7	Y	400	50	795	1305	2.40	65	72	72	18600	80
8	Y	400	50	760	1390	2.60	66	74	73	14810	110

Conn. = Connection · U = Supply voltage · f = Frequency · n = Speed · P_e = Power input · I = Current draw · LpA_{in} = Sound pressure level inlet side · LwA_{in} = Sound power level inlet side
LwA_{out} = Sound power level outlet side · qv = Air flow · p_{fs} = Pressure increase



Charts: Air flow 60 Hz

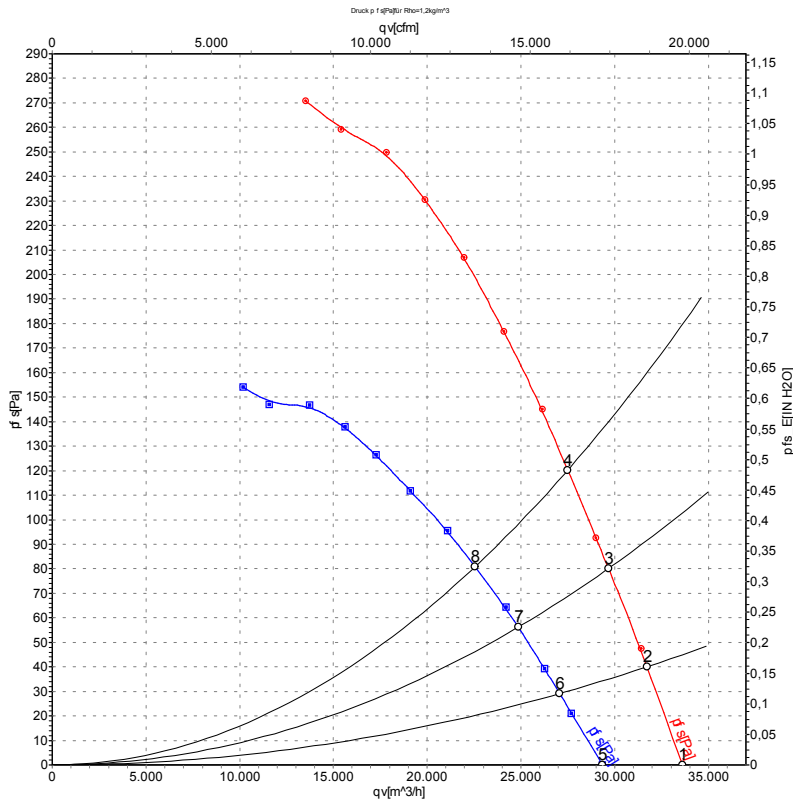

Measurement: LU-117508
Measurement: LU-118399

Air performance measured as per ISO 5801 Installation category A. For detailed information on the measuring set-up, please contact ebm-papst. Suction-side noise levels: LwA measured as per ISO 13347 / LpA measured with 1m distance to fan axis. The values given are valid under the measuring conditions mentioned above and may vary according to the actual installation situation. With any deviation from the standard set-up, the specific values have to be checked and reviewed with the unit installed.

Measured values

	Conn.	U	f	n	P _e	I	LpA _{in}	LwA _{in}	LwA _{out}	qv	p _{fs}
		V	Hz	min ⁻¹	W	A	dB(A)	dB(A)	dB(A)	m ³ /h	Pa
1	Δ	480	60	1130	2114	4.34	76	84	83	33610	0
2	Δ	480	60	1120	2334	4.59	75	82	82	31720	40
3	Δ	480	60	1115	2541	4.80	74	81	81	29670	80
4	Δ	480	60	1100	2770	5.03	74	81	81	27500	120
5	Y	480	60	995	1586	2.45	73	80	80	29350	0
6	Y	480	60	965	1738	2.68	70	78	78	27060	29
7	Y	480	60	935	1856	2.87	69	76	76	24860	56
8	Y	480	60	900	1960	3.05	68	75	75	22550	81

Conn. = Connection · U = Supply voltage · f = Frequency · n = Speed · P_e = Power input · I = Current draw · LpA_{in} = Sound pressure level inlet side · LwA_{in} = Sound power level inlet side · LwA_{out} = Sound power level outlet side · qv = Air flow · p_{fs} = Pressure increase

