

W6D800-KG13-01

# AC axial fan - AxiBlade

sickle-shaped blades (S series)

with square full nozzle

ASIA PACIFIC SHENGRUI LIMITED

Phone +00852 56261528

info@apacfan.com

www.apacfan.com

Limited partnership · Headquarters Mulfingen

Amtsgericht (court of registration) Stuttgart · HRA 590344

General partner Elektrobau Mulfingen GmbH · Headquarters Mulfingen

Amtsgericht (court of registration) Stuttgart · HRB 590142

## Nominal data

Type	W6D800-KG13-01		
Motor	M6D138-HF		
Phase		3~	3~
Nominal voltage	VAC	400	400
Wiring		Δ	Y
Frequency	Hz	50	50
Method of obtaining data		ml	ml
Valid for approval/standard		CE	CE
Speed (rpm)	min <sup>-1</sup>	870	650
Power consumption	W	1430	840
Current draw	A	2.8	1.6
Max. back pressure	Pa	155	80
Max. back pressure	in. wg	0.62	0.32
Min. ambient temperature	°C	-25	-25
Max. ambient temperature	°C	60	60
Starting current	A	9	3

ml = Max. load · me = Max. efficiency · fa = Free air · cs = Customer specification · ce = Customer equipment  
Subject to change

## Data according to Commission Regulation (EU) 327/2011

		Actual	Req. 2015
01 Overall efficiency $\eta_{es}$	%	41.8	34.5
02 Measurement category		A	
03 Efficiency category		Static	
04 Efficiency grade N		47.3	40
05 Variable speed drive		No	

Data obtained at optimum efficiency level.

The ErP data is determined using a motor-impeller combination in a standardized measurement setup.

09 Power consumption $P_e$	kW	1.33
09 Air flow $q_v$	m <sup>3</sup> /h	14615
09 Pressure increase $p_{fs}$	Pa	138
10 Speed (rpm) n	min <sup>-1</sup>	880
11 Specific ratio*		1.00

\* Specific ratio =  $1 + p_{fs} / 100\,000\text{ Pa}$

LU-179026



ebmpapst

W6D800-KG13-01

# AC axial fan - AxiBlade

sickle-shaped blades (S series)

with square full nozzle

## Technical description

<b>Weight</b>	44 kg
<b>Fan size</b>	800 mm
<b>Rotor surface</b>	Cast in aluminum
<b>Terminal box material</b>	PP plastic
<b>Blade material</b>	PP plastic
<b>Fan housing material</b>	Sheet steel, galvanized and coated with black plastic (RAL 9005)
<b>Guard grille material</b>	Steel, coated with black plastic (RAL 9005)
<b>Number of blades</b>	5
<b>Blade pitch</b>	0°
<b>Airflow direction</b>	"V"
<b>Direction of rotation</b>	Clockwise, viewed toward rotor
<b>Degree of protection</b>	IP54
<b>Insulation class</b>	"F"
<b>Moisture (F) / Environmental (H) protection class</b>	H2
<b>Ambient temperature note</b>	Occasional start-up between -40°C and -25°C is permissible. For continuous operation at temperatures below -25°C (e.g. refrigeration applications) we recommend our fan design with special low-temperature bearings.
<b>Max. permitted ambient temp. for motor (transport/storage)</b>	+80 °C
<b>Min. permitted ambient temp. for motor (transport/storage)</b>	-40 °C
<b>Installation position</b>	Any
<b>Condensation drainage holes</b>	On rotor and stator sides
<b>Mode</b>	S1
<b>Motor bearing</b>	Ball bearing
<b>Touch current according to IEC 60990 (measuring circuit Fig. 4, TN system)</b>	<= 3.5 mA
<b>Electrical hookup</b>	Via terminal box
<b>Motor protection</b>	Thermal overload protector (TOP) with basic insulation
<b>Protection class</b>	I (with customer connection of protective earth)
<b>Conformity with standards</b>	EN 60034-1 (2010); EN 61800-5-1; CE
<b>Approval</b>	VDE; EAC



W6D800-KG13-01

# AC axial fan - AxiBlade

sickle-shaped blades (S series)

with square full nozzle

## Product drawing

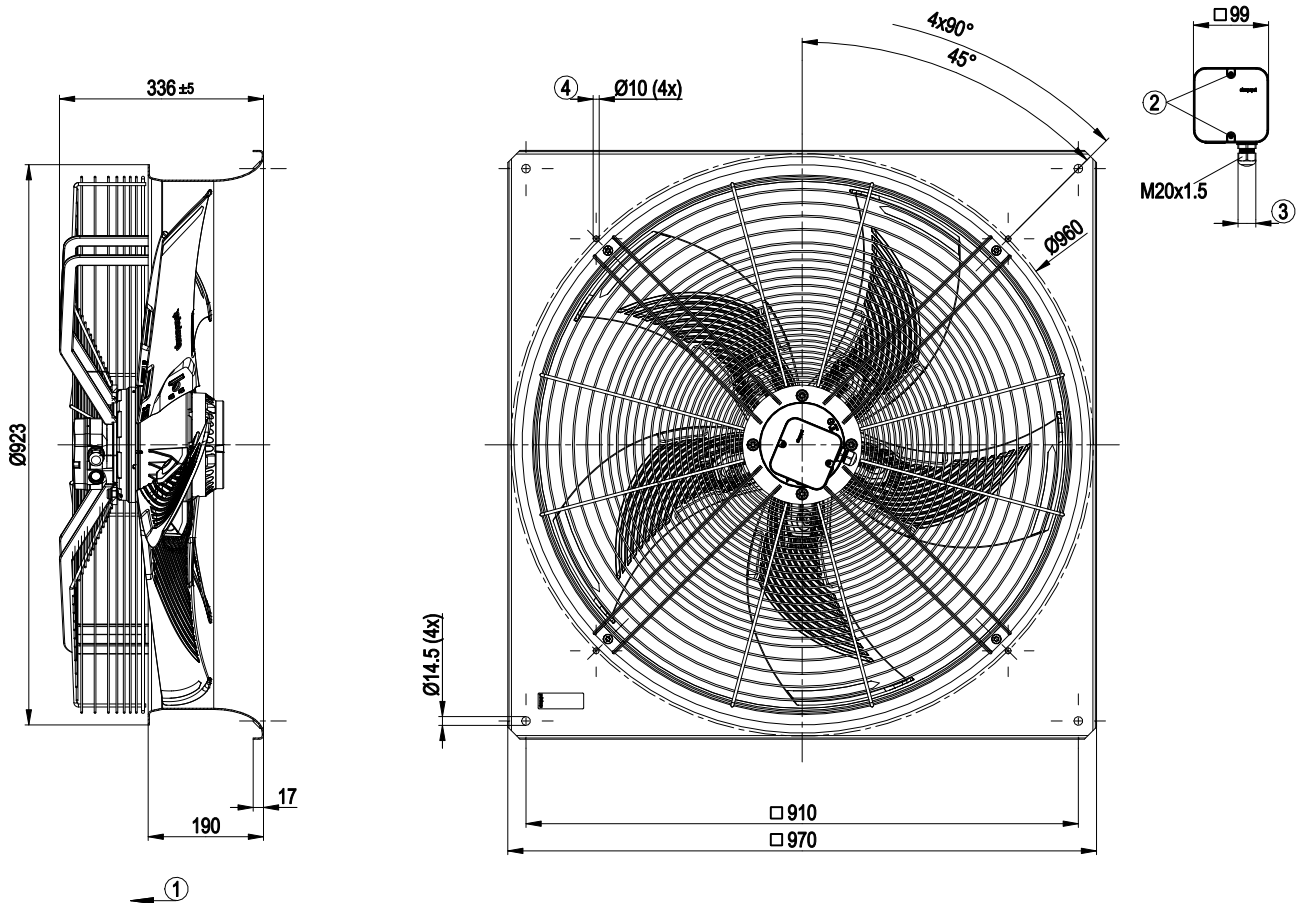

1	Airflow direction "V"
2	Tightening torque $1.5 \pm 0.2$ Nm
3	Cable diameter: min. 7 mm, max. 14 mm, tightening torque $2 \pm 0.3$ Nm
4	Mounting holes for FlowGrid



# AC axial fan - AxiBlade

sickle-shaped blades (S series)

with square full nozzle

## Connection diagram

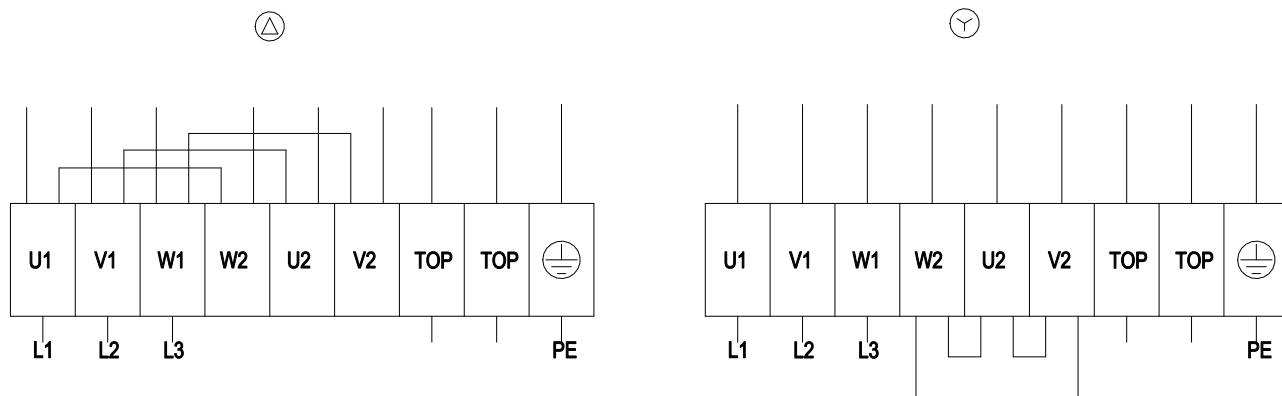

Δ	Delta connection	Y	Star connection	L1	= U1 = black
L2	= V1 = blue	L3	= W1 = brown	W2	yellow
U2	green	V2	white	TOP	2x gray
PE	green/yellow				

# AC axial fan - AxiBlade

sickle-shaped blades (S series)

with square full nozzle

## Curves: Air performance 50 Hz

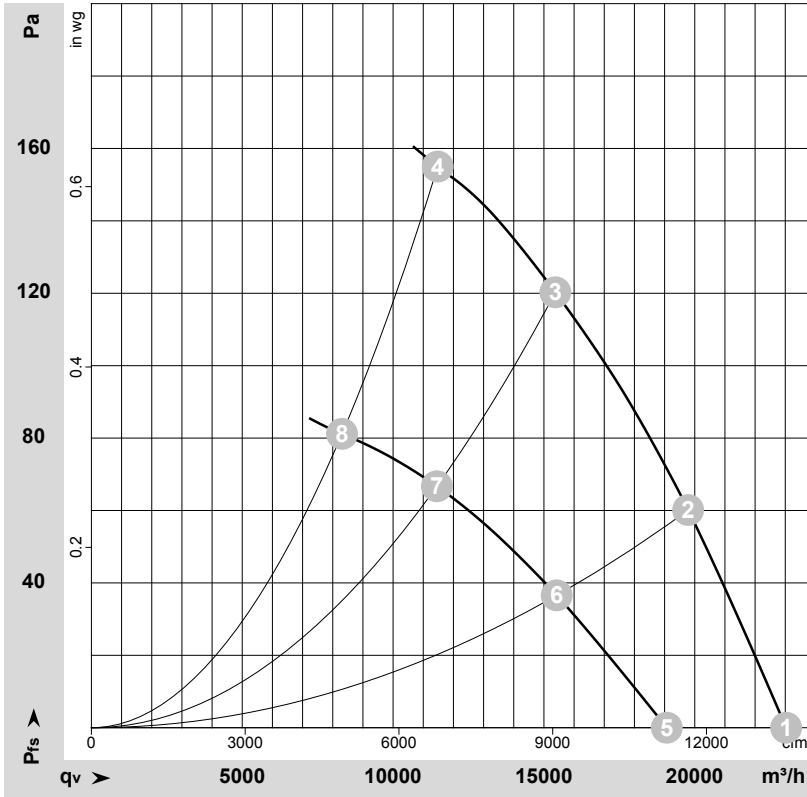

$\rho = 1.15 \text{ kg/m}^3 \pm 2 \%$

Measurement: LU-178965-1  
Measurement: LU-179021-1

Air performance measured according to ISO 5801 installation category A. For detailed information on the measurement setup, contact ebmpapst. Intake sound level: Sound power level according to ISO 13347 / sound pressure level measured at 1 m distance from fan axis. The values given are valid under the specified measuring conditions and may vary due to conditions of installation. For deviations from the standard configuration, the parameters have to be checked on the installed unit.

## Measured values

	Wired	U	f	n	P <sub>e</sub>	I	LpA <sub>in</sub>	LwA <sub>in</sub>	LwA <sub>out</sub>	q <sub>v</sub>	p <sub>fs</sub>	q <sub>v</sub>	p <sub>fs</sub>
		V	Hz	min <sup>-1</sup>	W	A	dB(A)	dB(A)	dB(A)	m <sup>3</sup> /h	Pa	cfm	in. wg
1	Δ	400	50	925	962	2.27	67	74	75	23030	0	13555	0.00
2	Δ	400	50	900	1163	2.50	66	73	73	19780	60	11645	0.24
3	Δ	400	50	880	1334	2.71	66	73	74	15380	120	9050	0.48
4	Δ	400	50	870	1430	2.80	74	82	83	11480	155	6755	0.62
5	Y	400	50	755	692	1.29	62	69	69	19070	0	11225	0.00
6	Y	400	50	700	776	1.47	61	67	67	15425	37	9080	0.15
7	Y	400	50	655	830	1.59	59	66	66	11450	67	6740	0.27
8	Y	400	50	650	840	1.60	64	72	72	8305	81	4890	0.33

Wired = Wiring · U = Power supply · f = Frequency · n = Speed (rpm) · P<sub>e</sub> = Power consumption · I = Current draw · LpA<sub>in</sub> = Sound pressure level intake side · LwA<sub>in</sub> = Sound power level intake side  
LwA<sub>out</sub> = Sound power level outlet side · q<sub>v</sub> = Air flow · p<sub>fs</sub> = Pressure increase

