

## ASIA PACIFIC SHENGRUI LIMITED

Phone +00852 56261528

info@apacfan.com

www.apacfan.com



## Nominal data

Type	W6D800-GD01-01		
Motor	M6D138-LA		
Phase		3~	3~
Nominal voltage	VAC	400	400
Connection		Δ	Y
Frequency	Hz	50	50
Type of data definition		ml	ml
Valid for approval / standard		CE	CE
Speed	min <sup>-1</sup>	880	670
Power input	W	1940	1210
Current draw	A	3.9	2.23
Max. back pressure	Pa	160	92
Min. ambient temperature	°C	-40	-40
Max. ambient temperature	°C	60	60
Starting current	A	13	4.3

ml = Max. load · me = Max. efficiency · fa = Running at free air · cs = Customer specs · cu = Customer unit  
Subject to alterations

## Data according to ErP directive

Installation category	A
Efficiency category	Static
Variable speed drive	No
Specific ratio*	1.00

\* Specific ratio =  $1 + p_{fs} / 100\,000\text{ Pa}$

		Actual	Request 2013	Request 2015
Overall efficiency $\eta_{es}$	%	35.2	31.2	35.2
Efficiency grade N		40	36	40
Power input $P_e$	kW	1.72		
Air flow $q_v$	m <sup>3</sup> /h	17215		
Pressure increase $p_{fs}$	Pa	124		
Speed n	min <sup>-1</sup>	905		

Data definition with optimum efficiency. LU-122313  
The ErP data is determined using a motor-impeller combination in a standardised measurement configuration.



## Technical features

<b>Mass</b>	44 kg
<b>Size</b>	800 mm
<b>Surface of rotor</b>	Cast in aluminium
<b>Material of terminal box</b>	PP plastic
<b>Material of blades</b>	Aluminium sheet insert, sprayed with PP plastic
<b>Material of wall ring</b>	Sheet steel, pre-galvanised and coated in black plastic (RAL 9005)
<b>Material of guard grille</b>	Steel, coated in black plastic (RAL9005)
<b>Number of blades</b>	5
<b>Blade angle</b>	0
<b>Direction of air flow</b>	"V"
<b>Direction of rotation</b>	Clockwise, seen on rotor
<b>Type of protection</b>	IP 54
<b>Insulation class</b>	"F"
<b>Humidity class</b>	F3-1
<b>Max. permissible ambient motor temp. (transp./ storage)</b>	+ 80 °C
<b>Min. permissible ambient motor temp. (transp./storage)</b>	- 40 °C
<b>Mounting position</b>	Any
<b>Condensate discharge holes</b>	On rotor and stator sides
<b>Operation mode</b>	S1
<b>Motor bearing</b>	Ball bearing
<b>Touch current acc. IEC 60990 (measuring network Fig. 4, TN system)</b>	<= 3.5 mA
<b>Electrical leads</b>	Via terminal box
<b>Motor protection</b>	Thermal overload protector (TOP) brought out
<b>Cable exit</b>	Axial
<b>Protection class</b>	I (if protective earth is connected by customer)
<b>Product conforming to standard</b>	EN 60034; EN 61800-5-1; CE
<b>Approval</b>	EAC; VDE

# AC axial fan - HyBlade®

sickled blades (S series)

with full square nozzle

## Product drawing

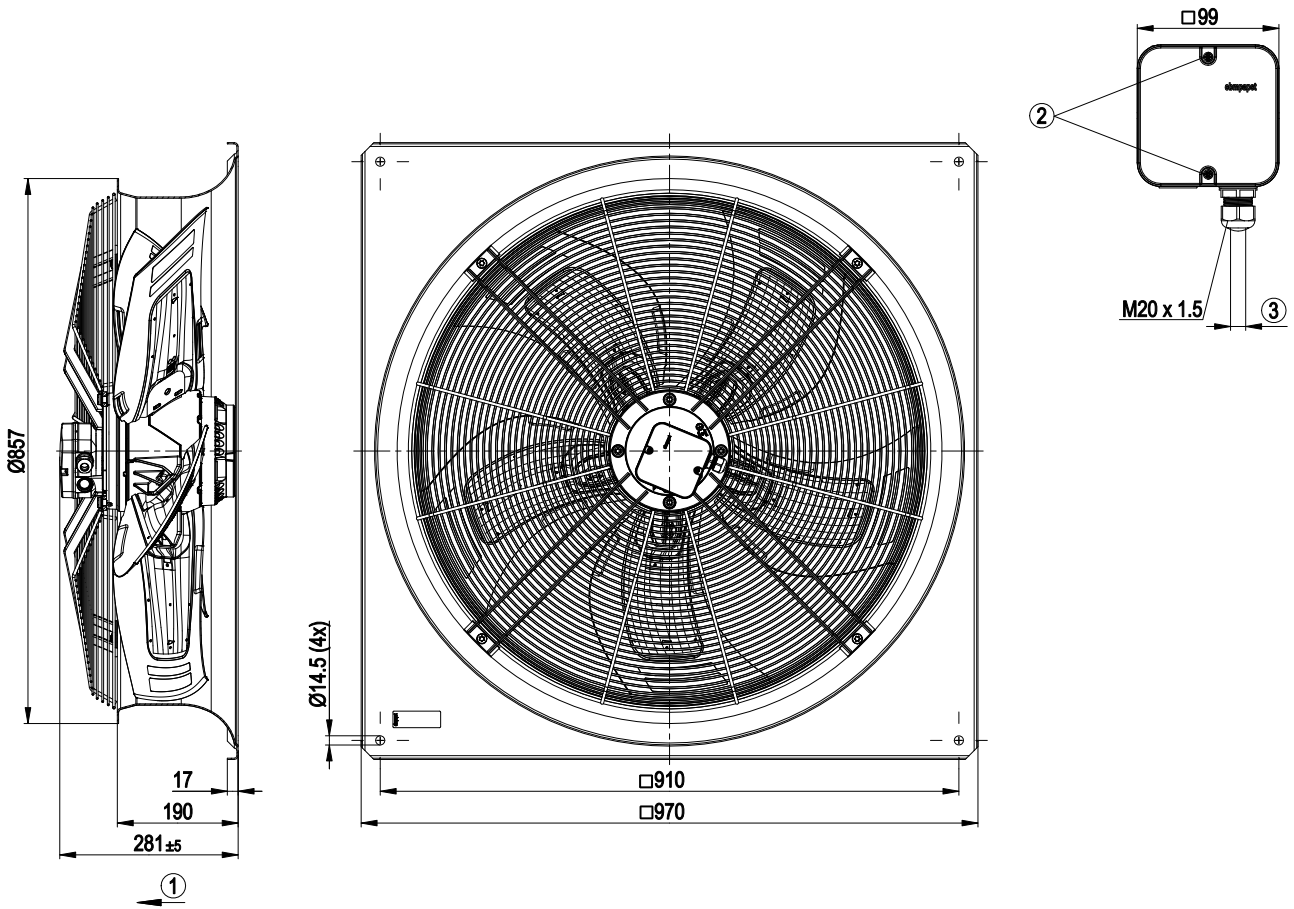

1	Direction of air flow "V"
2	Tightening torque $1.5 \pm 0.2$ Nm
3	Cable diameter: min. 7 mm, max. 14 mm, tightening torque: $2 \pm 0.3$ Nm

# AC axial fan - HyBlade®

sickled blades (S series)

with full square nozzle

## Connection screen

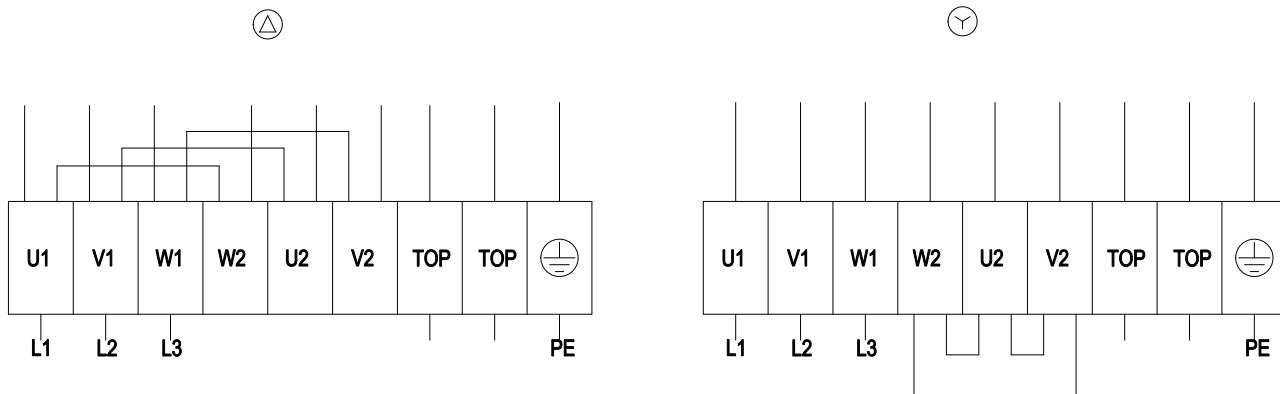

Δ	Delta connection	Y	Star connection	L1	= U1 = black
L2	= V1 = blue	L3	= W1 = brown	W2	yellow
U2	green	V2	white	TOP	2 x grey
PE	green/yellow				

## Charts: Air flow 50 Hz

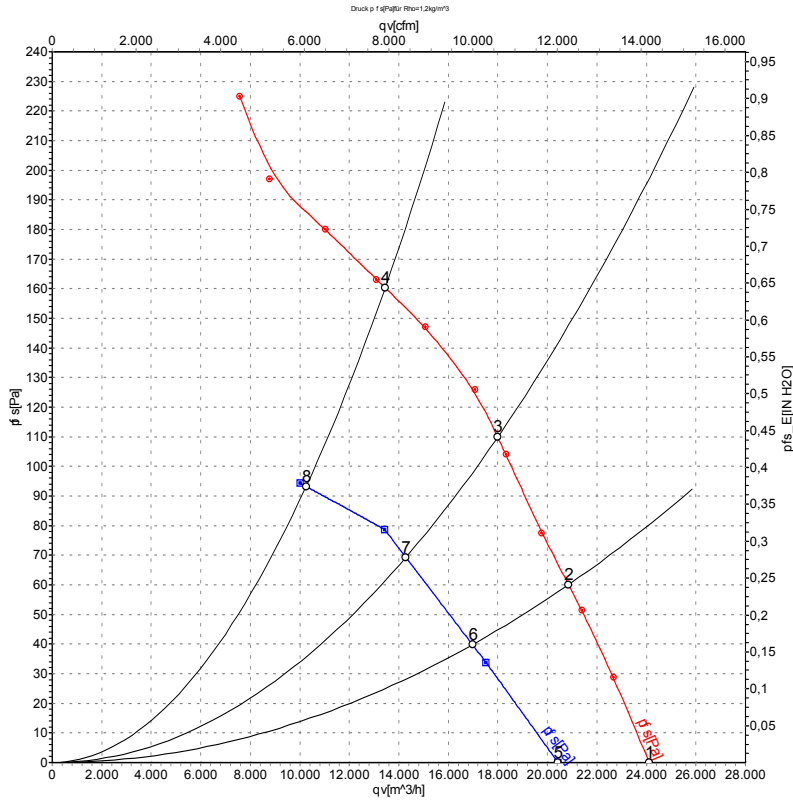

Air performance measured as per ISO 5801 Installation category A. For detailed information on the measuring set-up, please contact ebm-papst. Suction-side noise levels: LwA measured as per ISO 13347 / LpA measured with 1m distance to fan axis. The values given are valid under the measuring conditions mentioned above and may vary according to the actual installation situation. With any deviation from the standard set-up, the specific values have to be checked and reviewed with the unit installed.

## Measured values

	Conn.	U	f	n	P <sub>e</sub>	I	LpA <sub>in</sub>	LwA <sub>in</sub>	LwA <sub>out</sub>	qv	p <sub>fs</sub>
		V	Hz	min <sup>-1</sup>	W	A	dB(A)	dB(A)	dB(A)	m³/h	Pa
1	Δ	400	50	925	1380	3.30	65	72	72	24110	0
2	Δ	400	50	910	1581	3.44	65	72	71	20850	60
3	Δ	400	50	900	1720	3.60	66	73	72	17990	110
4	Δ	400	50	880	1940	3.90	70	77	76	13450	160
5	Y	400	50	780	1000	1.85	61	68	67	20430	0
6	Y	400	50	740	1079	1.98	60	66	66	16980	40
7	Y	400	50	710	1129	2.08	60	67	66	14290	69
8	Y	400	50	670	1210	2.23	62	70	69	10250	92

Conn. = Connection · U = Supply voltage · f = Frequency · n = Speed · P<sub>e</sub> = Power input · I = Current draw · LpA<sub>in</sub> = Sound pressure level inlet side · LwA<sub>in</sub> = Sound power level inlet side · LwA<sub>out</sub> = Sound power level outlet side · qv = Air flow · p<sub>fs</sub> = Pressure increase