



ASIA PACIFIC SHENGRUI LIMITED

Phone +00852 56261528

info@apacfan.com

www.apacfan.com



Nominal data

Type	W3G300-BV25-23	
Motor	M3G084-BF	
Nominal voltage	VDC	26
Nominal voltage range	VDC	16 .. 32
Type of data definition		fa
Speed	min ⁻¹	3940
Power input	W	380
Current draw	A	14.6
Min. ambient temperature	°C	-40
Max. ambient temperature	°C	85/110

ml = Max. load · me = Max. efficiency · fa = Running at free air · cs = Customer specs · cu = Customer unit
Subject to alterations

Data according to ErP directive

Installation category	A
Efficiency category	Static
Variable speed drive	Yes
Specific ratio*	1.00

* Specific ratio = $1 + p_b / 100\,000\text{ Pa}$

		Actual	Request 2013	Request 2015
Overall efficiency η_{es}	%	44.8	27.5	31.5
Efficiency grade N		53.3	36	40
Power input P_e	kW	0.46		
Air flow q_v	m ³ /h	2205		
Pressure increase p_{fs}	Pa	306		
Speed n	min ⁻¹	3720		

Data definition with optimum efficiency.
The ErP data is determined using a motor-impeller combination in a standardised measurement configuration.



Technical features

Mass	2 kg
Size	300 mm
Material of impeller	PA plastic
Material of wall ring	PA plastic
Number of blades	7
Direction of air flow	"V"
Direction of rotation	Clockwise, seen on rotor
Type of protection	IP 24 KM; (Motor); electronics IP 66 / 69 K
Insulation class	"B"
Humidity class	F4-1
Max. permissible ambient motor temp. (transp./ storage)	+110 °C
Min. permissible ambient motor temp. (transp./storage)	-40 °C
Mounting position	Any
Condensate discharge holes	None, open rotor
Operation mode	S1
Motor bearing	Ball bearing
Technical features	<ul style="list-style-type: none"> - Direction of rotation selection counter-clockwise / clockwise - Fault output (high-side switch max. 30 mA) - Output limit - Motor current limit - Soft start
EMC directives	ECE R10 Rev.3
Electrical leads	With plug
Motor protection	Reverse polarity and locked-rotor protection
Cable exit	Lateral

Product drawing

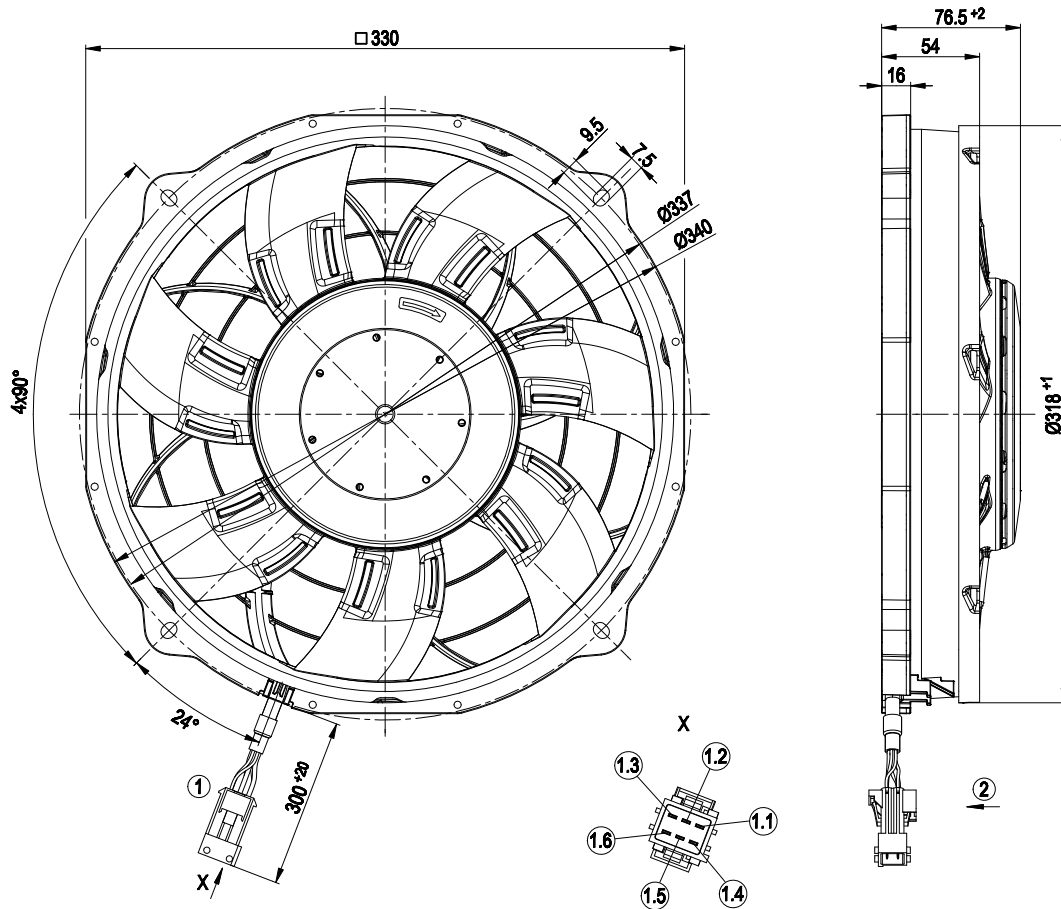

1	Connection line with plug AMP Junior Power Timer, 6-pole, coded Accessory part: connection line (460 mm) with mating connector Part No. 02002-4-1021 not included in the standard scope of delivery
1.1	+ UB (black)
1.2	GND (brown)
1.3	PWMLIN (yellow) optional LIN-BUS
1.4	INVLIN (orange)
1.5	Reverse (blue)
1.6	Diagnostic output (white)
2	Direction of air flow "V"

Connection screen

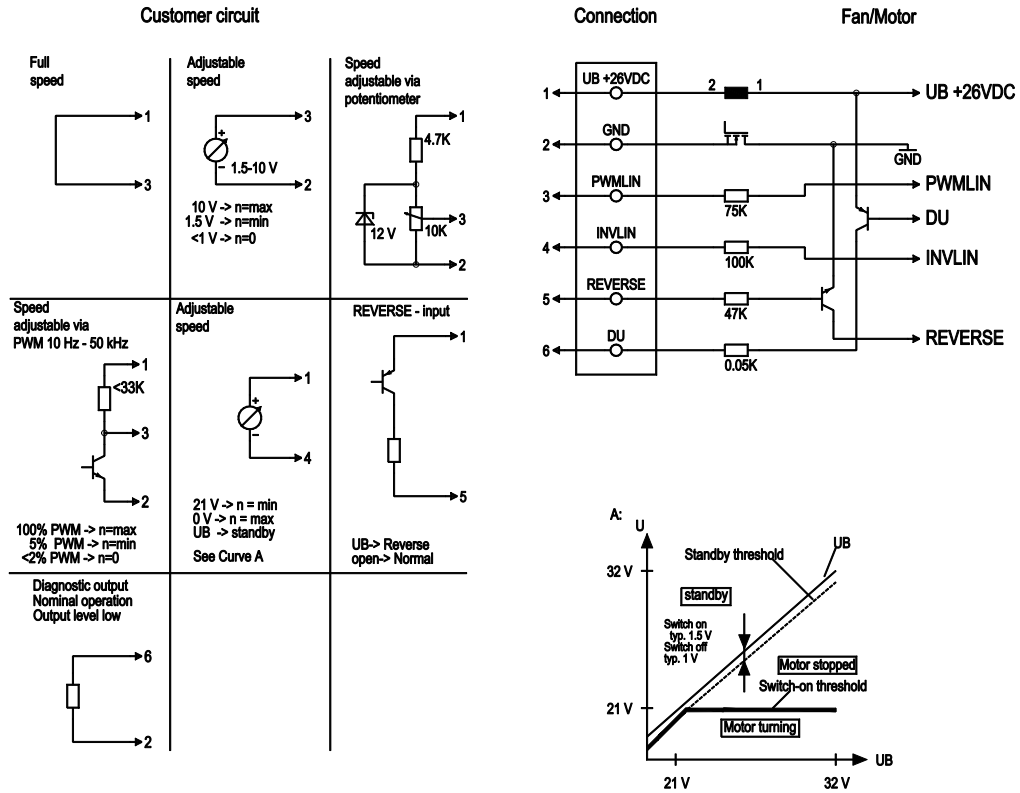

No.	Pin	Signal	Function / assignment
	1	UB +26 VDC	Power supply 26 VDC
	2	GND	Power supply GND, reference ground
	3	PWMLIN	Analogue voltage control input 0-10 V or PWM
	4	INVLIN	Control input, inverse linear
	5	REVERSE	Input for changing direction of rotation
	6	DU	Diagnostic output

Charts: Air flow

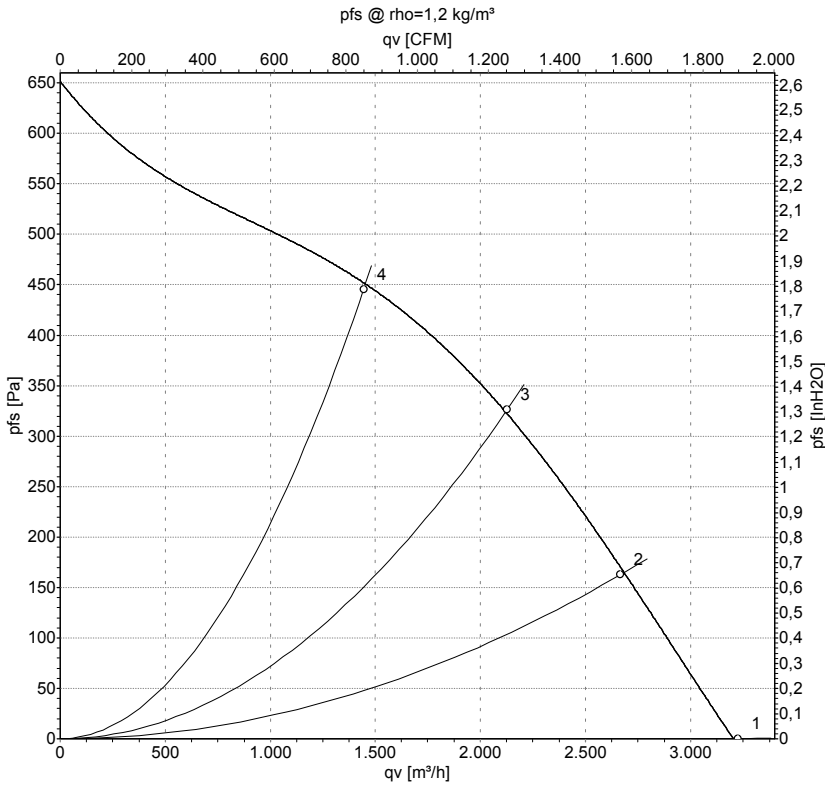

Measurement: LU-141116

Air performance measured as per ISO 5801 Installation category A. For detailed information on the measuring set-up, please contact ebm-papst. Suction-side noise levels: LwA measured as per ISO 13347 / LpA measured with 1m distance to fan axis. The values given are valid under the measuring conditions mentioned above and may vary according to the actual installation situation. With any deviation from the standard set-up, the specific values have to be checked and reviewed with the unit installed.

Measured values

	U	n	P _{ed}	I	LpA _{in}	LwA _{in}	qv	p _{fs}
	V	min ⁻¹	W	A	dB(A)	dB(A)	m³/h	Pa
1	26	3940	380	14.60	79	87	3225	0
2	26	3815	408	15.68	79	87	2665	160
3	26	3715	462	17.74	78	85	2130	325
4	26	3630	495	19.01	81	88	1445	445

U = Supply voltage · n = Speed · P_{ed} = Power input · I = Current draw · LpA_{in} = Sound pressure level inlet side · LwA_{in} = Sound power level inlet side · qv = Air flow · p_{fs} = Pressure increase