

ASIA PACIFIC SHENGRUI LIMITED

Phone +00852 56261528

info@apacfan.com

www.apacfan.com

Nominal data

Type	W3G200-HD01-03	
Motor	M3G055-BD	
Phase		1~
Nominal voltage	VAC	230
Nominal voltage range	VAC	200 .. 240
Frequency	Hz	50/60
Type of data definition		ml
Speed	min ⁻¹	2900
Power input	W	54
Current draw	A	0.55
Max. back pressure	Pa	96
Min. ambient temperature	°C	-25
Max. ambient temperature	°C	60

ml = Max. load · me = Max. efficiency · fa = Running at free air · cs = Customer specs · cu = Customer unit
Subject to alterations



Technical features

Mass	1.7 kg
Size	200 mm
Surface of rotor	Thick layer passivated
Material of blades	PP plastic
Number of blades	7
Direction of air flow	"V"
Direction of rotation	Counter-clockwise, seen on rotor
Type of protection	IP 54; Depending on installation and position
Insulation class	"B"
Max. permissible ambient motor temp. (transp./ storage)	+ 80 °C
Min. permissible ambient motor temp. (transp./storage)	- 40 °C
Mounting position	Any
Condensate discharge holes	None, open rotor
Operation mode	S1
Motor bearing	Ball bearing
Technical features	<ul style="list-style-type: none"> - Output 10 VDC, max. 1.1 mA - Tach output - Motor current limit - Soft start - Control input 0-10 VDC / PWM - Control interface with SELV potential safely disconnected from the mains - Over-temperature protected electronics / motor
EMC interference immunity	Acc. to EN 61000-6-2 (industrial environment)
EMC harmonics	Acc. to EN 61000-3-2/3
EMC interference emission	Acc. to EN 55022 (Class B, household environment), on account of the installation conditions, ferritic damping in the connection line may be required for the application.
Touch current acc. IEC 60990 (measuring network Fig. 4, TN system)	<= 3.5 mA
Electrical leads	Via terminal strip
Motor protection	Locked-rotor protection
Cable exit	Variable
Protection class	I (if protective earth is connected by customer)
Product conforming to standard	EN 60335-1; CE
Approval	UL 2111; CSA C22.2 Nr.77

EC axial compact fan

sickled blades (S series)

Product drawing

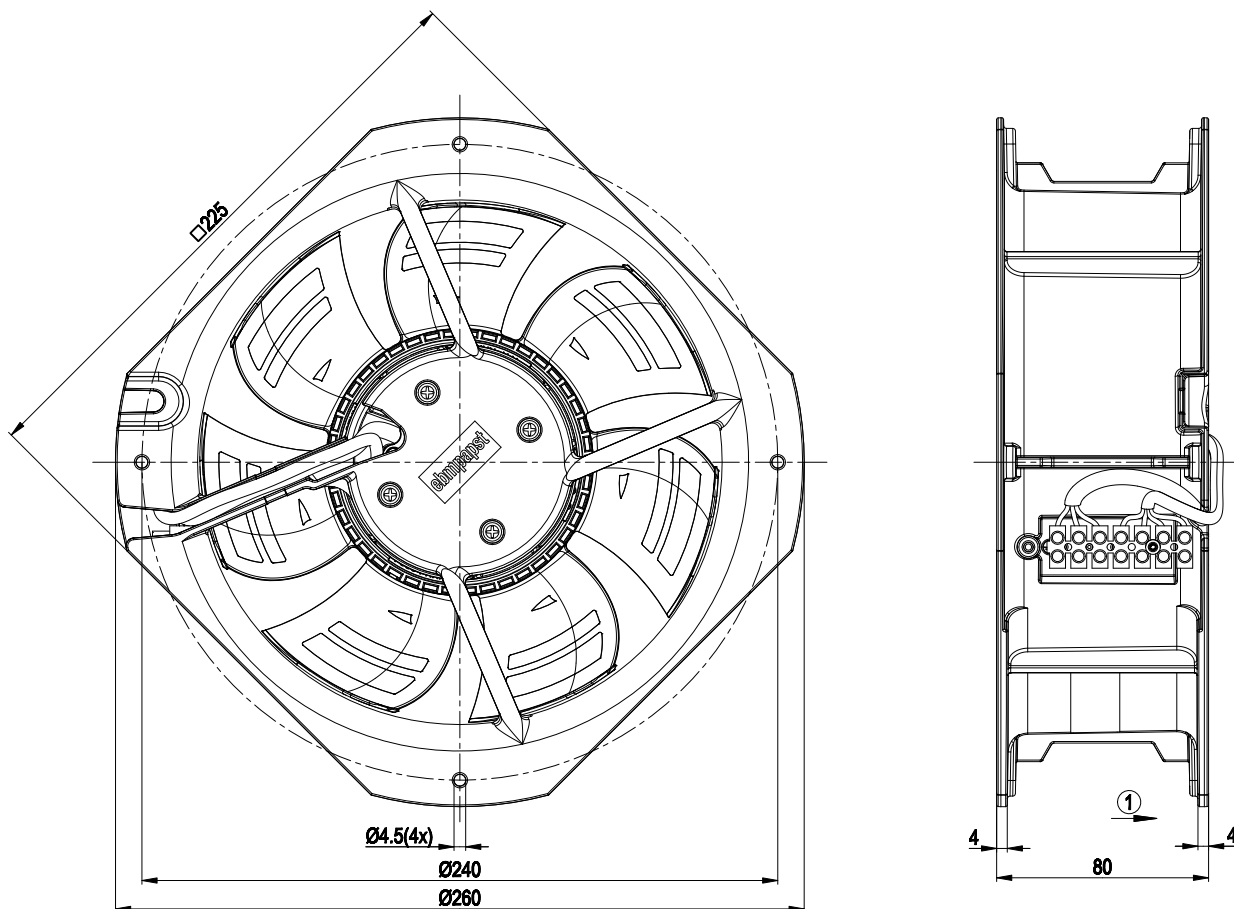

1 Direction of air flow "V"



Connection screen

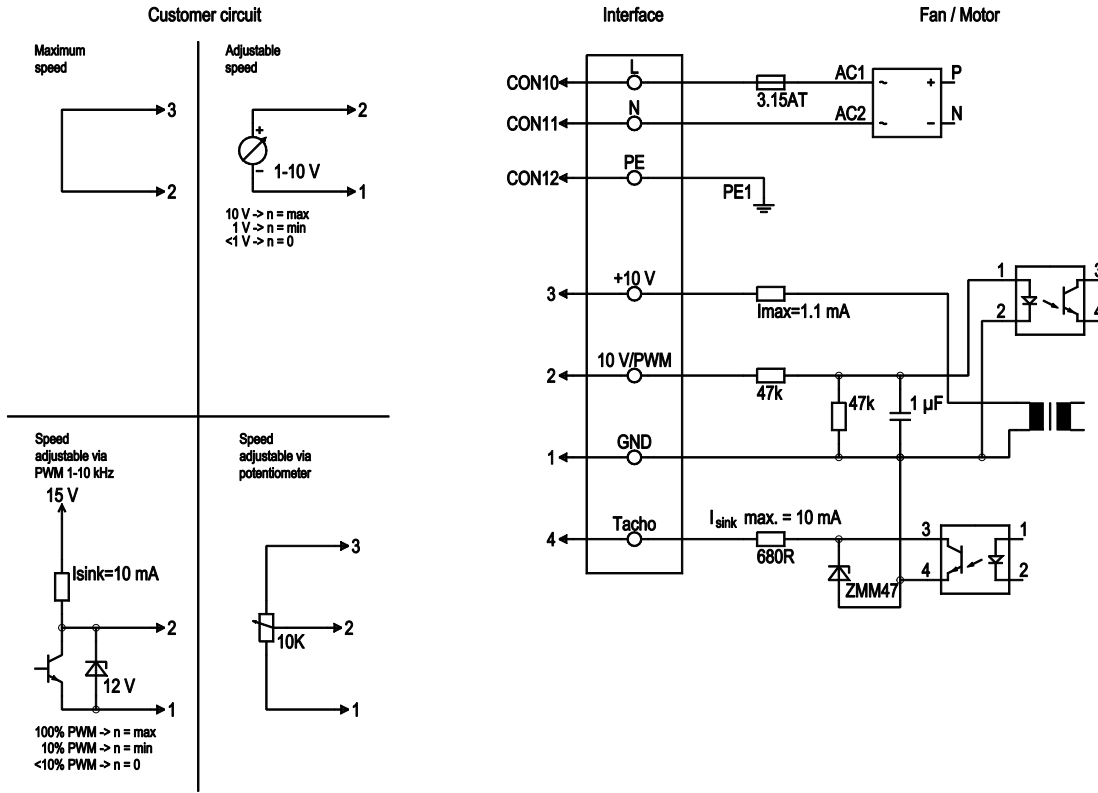

No.	Conn.	Designation	Colour	Function / assignment
	CON10	L	black	Power supply 230 VAC, 50-60 Hz, for voltage range refer to rating plate
	CON11	N	blue	Neutral conductor
	CON12	PE	green/yellow	Protective earth
	1	GND	blue	GND - Connection for control interface
	2	0- 10V PWM	yellow	Control input 0 - 10 V or PWM, electrically isolated
	3	10V/ max 1.1mA	red	Voltage output 10 V / 1.1 mA, electrically isolated, not short-circuit-proof
	4	Tach	white	Tach output: open collector, 1 pulse per revolution, electrically isolated, Isink max = 10 mA

Charts: Air flow 50 Hz

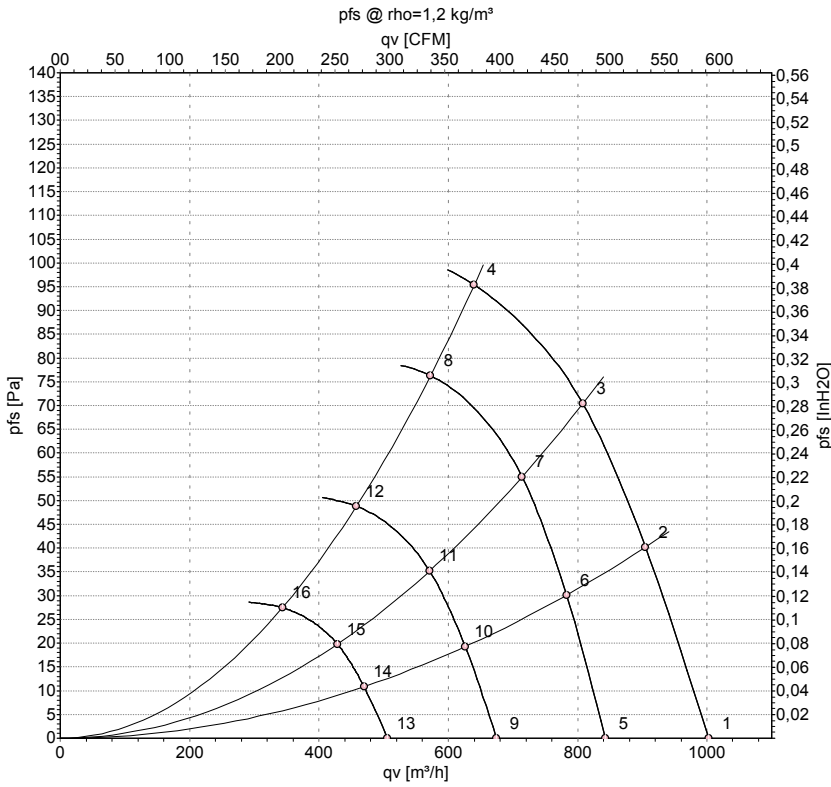

Measurement: LU-155339

Air performance measured as per ISO 5801 Installation category A. For detailed information on the measuring set-up, please contact ebm-papst. Suction-side noise levels: LwA measured as per ISO 13347 / LpA measured with 1m distance to fan axis. The values given are valid under the measuring conditions mentioned above and may vary according to the actual installation situation. With any deviation from the standard set-up, the specific values have to be checked and reviewed with the unit installed.

Measured values

	U	f	n	P _{ed}	I	LpA _{in}	LwA _{in}	qv	p _{fs}
	V	Hz	min ⁻¹	W	A	dB(A)	dB(A)	m ³ /h	Pa
1	230	50	2970	50	0.49	58	65	1000	0
2	230	50	2890	54	0.53	57	64	905	40
3	230	50	2830	58	0.56	58	65	810	70
4	230	50	2900	54	0.55	62	70	640	96
5	230	50	2500	29	0.29	54	61	845	0
6	230	50	2500	35	0.34	53	61	785	30
7	230	50	2500	40	0.39	55	62	715	56
8	230	50	2500	41	0.40	59	67	570	77
9	230	50	2000	15	0.15	48	55	675	0
10	230	50	2000	18	0.18	48	55	625	19
11	230	50	2000	21	0.20	49	56	570	36
12	230	50	2000	21	0.21	54	61	460	49
13	230	50	1500	6.0	0.06	41	48	505	0
14	230	50	1500	8.0	0.07	41	48	470	11
15	230	50	1500	9.0	0.08	42	49	430	20
16	230	50	1500	9.0	0.09	46	54	345	28

U = Supply voltage · f = Frequency · n = Speed · P_{ed} = Power input · I = Current draw · LpA_{in} = Sound pressure level inlet side · LwA_{in} = Sound power level inlet side · qv = Air flow
 p_{fs} = Pressure increase

