

ASIA PACIFIC SHENGRUI LIMITED
 Phone +00852 56261528
 info@apacfan.com
 www.apacfan.com

Nominal data

Type	W2E142-BB01-01		
Motor	M2E052-BA		
Phase		1~	1~
Nominal voltage	[V]	230	230
Frequency	[Hz]	50	60
Type of data definition		rfa	rfa
Valid for approval / standard		CE	CE
Speed	[min ⁻¹]	2800	3350
Power input	[W]	27	28
Current draw	[A]	0.12	0.13
Motor capacitor	[μF]	1	1
Capacitor voltage	[VDB]	400	400
Capacitor standard		P0 (CE)	P0 (CE)
Max. ambient temperature	[°C]	55	65

ml = max. load · me = max. efficiency · rfa = running at free air · cs = customer specs · cu = customer unit
 Subject to alterations

Technical features

Leakage current	< 0.75 mA
Size	142 mm
Operation mode	S1
Direction of rotation	Counter-clockwise, seen on rotor
Mounting position	Any
Electrical leads	With plug
Direction of air flow	"V"
Insulation class	"B"
Condensate discharge holes	None
Bearing motor	Ball bearing
Mass	0.8 kg
Material of impeller	Sheet steel, coated in black
Material of wall ring	Die-cast aluminium, coated in black
Motor protection	Thermal overload protector (TOP) wired internally
Product conforming to standard	CE; EN 60335-1
Surface of rotor	Coated in black
Number of blades	7
Type of protection	IP 22; Depending on installation and position
Protection class	I (if earth wire is connected by customer)
Max. permissible ambient motor temp. (transp./ storage)	+ 80 °C
Min. permissible ambient motor temp. (transp./storage)	- 40 °C
Approval	CCC; CSA C22.2 Nr.113; GOST; UL 507; VDE

Product drawing

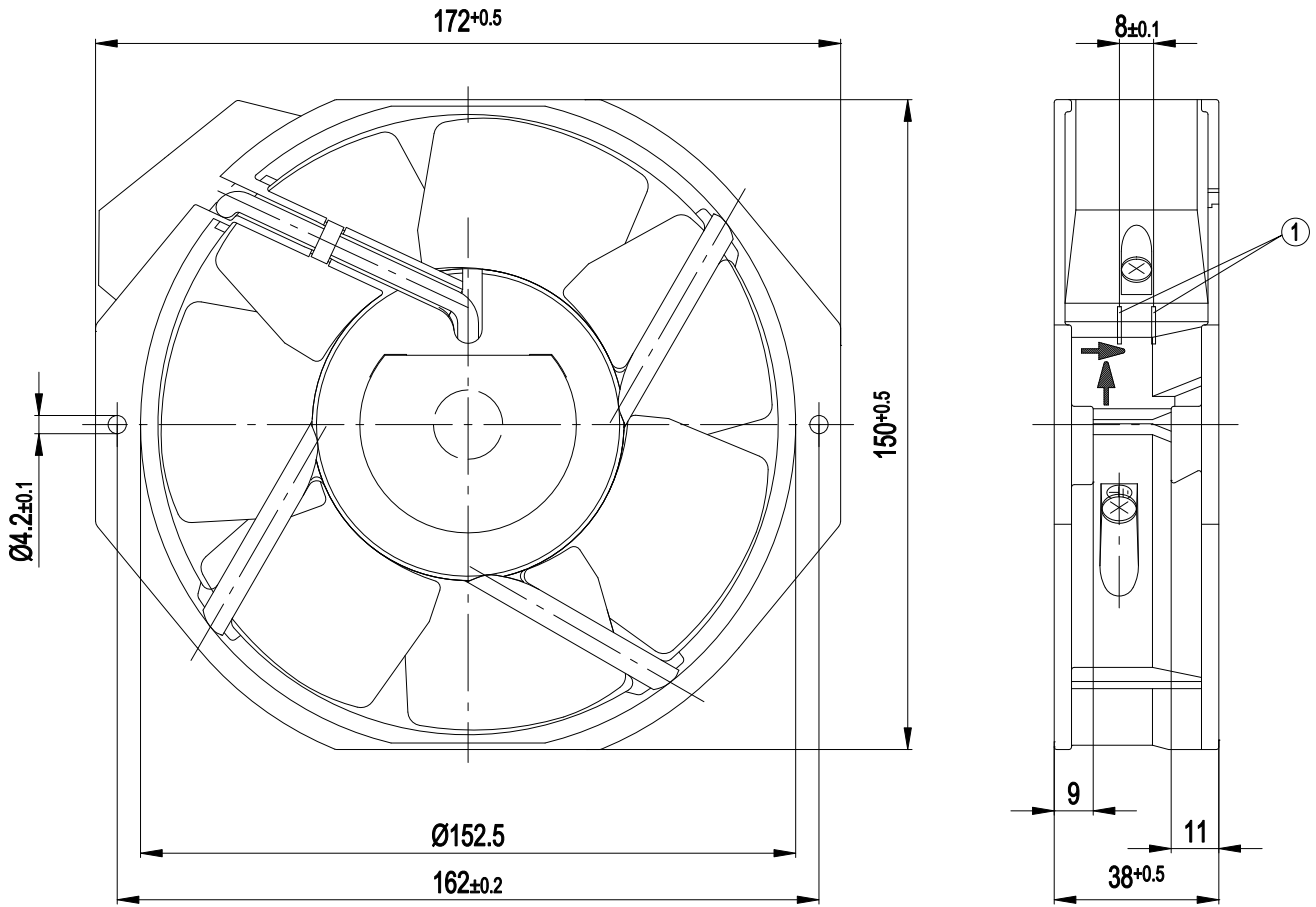

1 2x flat plug 2.8 x 0.5 mm

Connection screen

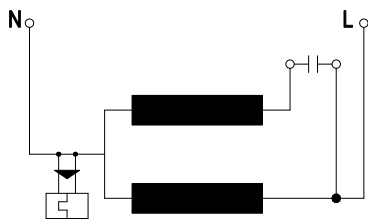

Charts: Air flow 50 Hz

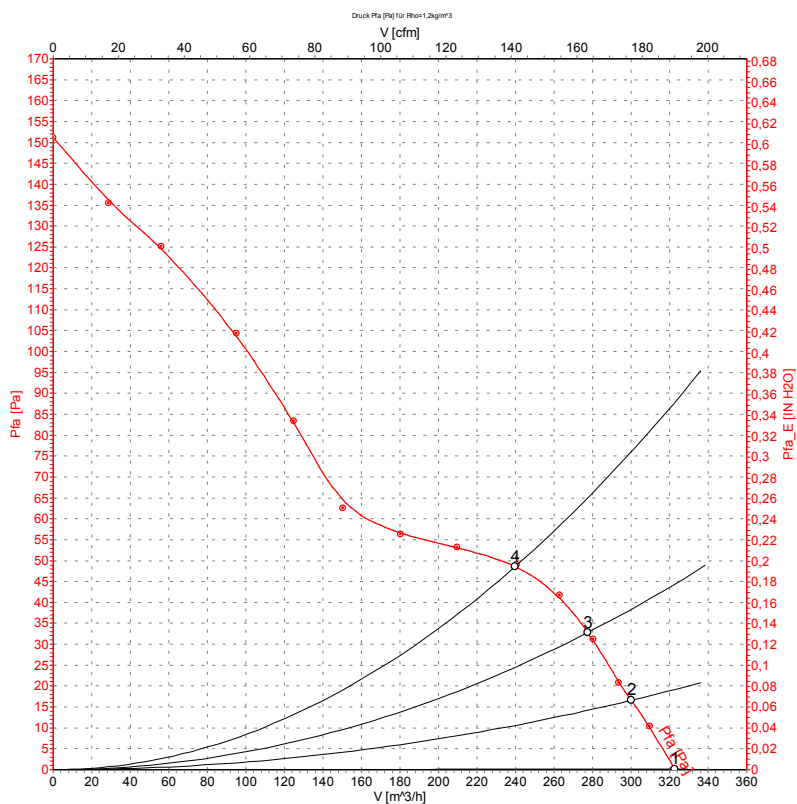

Measurement: LU-63820

Measured values

	U	f	n	P ₁	I	Ŷ	P _{fa}
	[V]	[Hz]	[min ⁻¹]	[W]	[A]	[m ³ /h]	[Pa]
1	230	50	2830	27	0.12	320	0
2	230	50	2810	27	0.12	300	17
3	230	50	2795	27	0.12	275	33
4	230	50	2775	27	0.12	240	50

Charts: Air flow 60 Hz

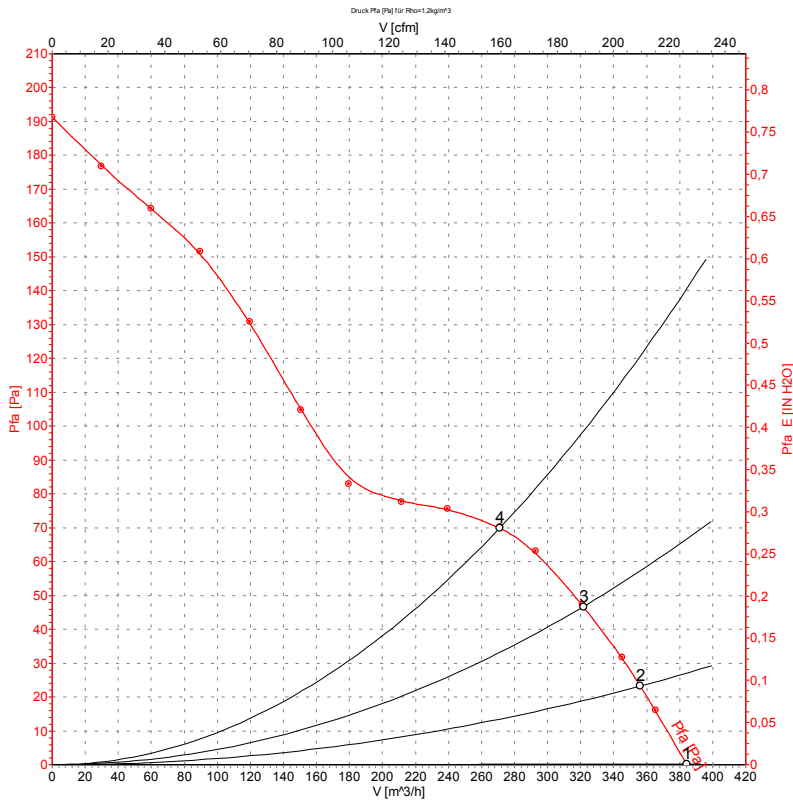

Measurement: LU-63821

Measured values

	U	f	n	P ₁	I	\hat{V}	P _{fa}
	[V]	[Hz]	[min ⁻¹]	[W]	[A]	[m ³ /h]	[Pa]
1	230	60	3350	28	0.13	385	0
2	230	60	3310	29	0.13	355	23
3	230	60	3270	30	0.13	320	47
4	230	60	3230	31	0.14	270	70