

AC axial fan

straight blades (A series)

with full square nozzle

ASIA PACIFIC SHENGRUI LIMITED

Phone +00852 56261528

info@apacfan.com

www.apacfan.com



Nominal data

Type	W2D250-GA02-07		
Motor	M2D068-DF		
Phase		3~	3~
Nominal voltage	VAC	400	400
Connection		Y	Y
Frequency	Hz	50	60
Type of data definition		fa	fa
Valid for approval / standard		CE	CE
Speed	min ⁻¹	2700	3000
Power input	W	112	180
Current draw	A	0.23	0.27
Max. back pressure	Pa	280	280
Max. ambient temperature	°C	60	50
Starting current	A	0.78	0.75

ml = max. load · me = max. efficiency · fa = running at free air · cs = customer specs · cu = customer unit
Subject to alterations

Data according to ErP directive

		Actual	Request 2013	Request 2015
Installation category	A			
Efficiency category	Static			
Variable speed drive	No			
Specific ratio*	1.00			
Overall efficiency η_{es}		28.1	24.1	28.1
Efficiency grade N		40	36	40
Power input P_e	kW	0.13		
Air flow q_v	m ³ /h	1050		
Pressure increase p_{fs}	Pa	121		
Speed n	min ⁻¹	2600		

Data established at point of optimum efficiency

* Specific ratio = $1 + p_b / 100\,000\text{ Pa}$



AC axial fan

straight blades (A series)

with full square nozzle

Technical features

Mass	2.9 kg
Size	250 mm
Surface of rotor	Coated in black
Material of impeller	Sheet steel, coated in black
Material of mounting ring	Steel, phosphated and coated in black plastic
Material of wall ring	Sheet steel, galvanised
Number of blades	5
Direction of air flow	"A"
Direction of rotation	Clockwise, seen on rotor
Type of protection	IP 44; Depending on installation and position
Insulation class	"B"
Humidity class	F1-2
Max. permissible ambient motor temp. (transp./ storage)	+ 80 °C
Min. permissible ambient motor temp. (transp./storage)	- 40 °C
Mounting position	Any
Condensate discharge holes	None
Operation mode	S1
Motor bearing	Ball bearing
Touch current acc. IEC 60990 (measuring network Fig. 4, TN system)	< 0.75 mA
Cable exit	Lateral
Protection class	I (if earth wire is connected by customer)
Product conforming to standard	EN 60335-1, motor does not have factory-installed overheating protection

AC axial fan

straight blades (A series)
with full square nozzle

Product drawing

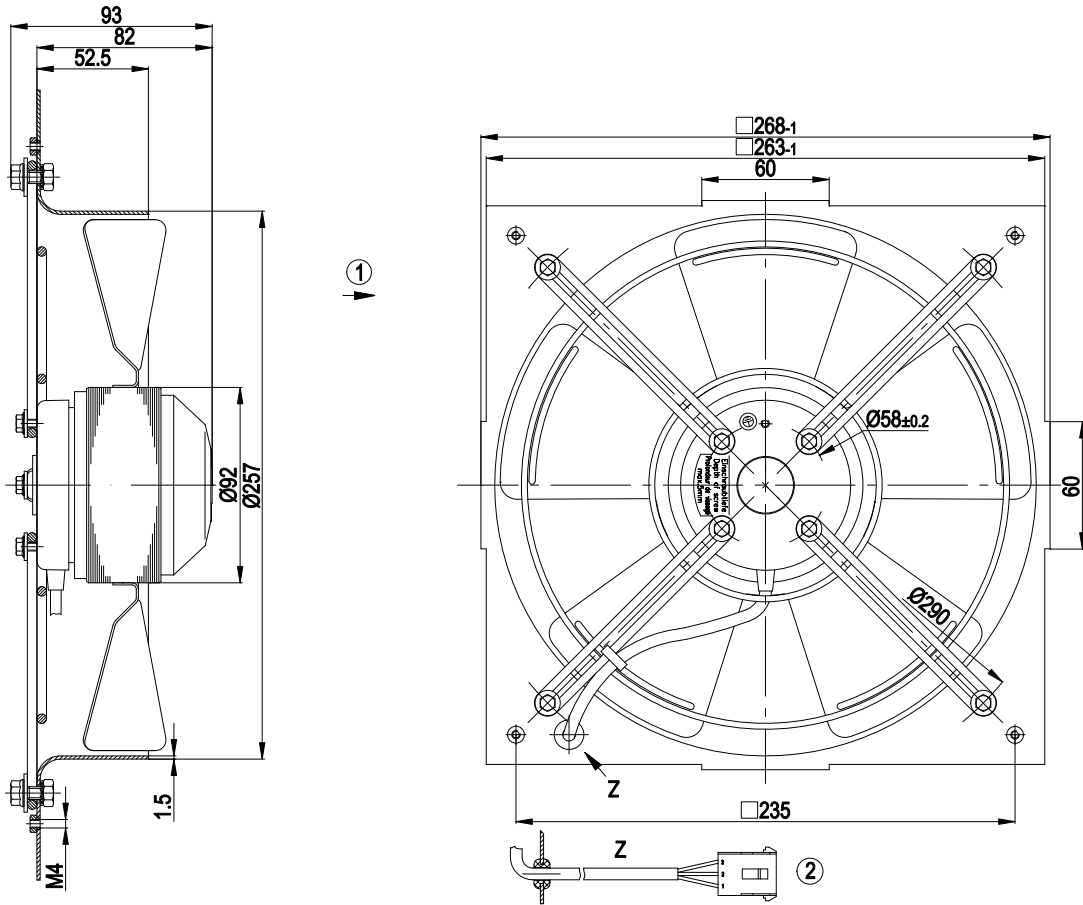

1	Direction of air flow "A"
2	Connection line PVC 3X 0.5 mm ² , length starting at stator bush 250 mm, connector housing Molex No. 350 767-1 crimped
Plug assignment:	
1	black = U1
2	blue = V1
3	brown = W1



AC axial fan

straight blades (A series)
with full square nozzle

Connection screen

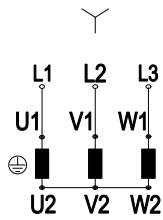

Note: Direction of rotation changes when two phases are reversed

Y	Star connection	L1	black	L2	blue
L3	brown	U1	black	V1	blue
W1	brown	U2	green	V2	white
W2	yellow				

AC axial fan

straight blades (A series)
with full square nozzle

Charts: Air flow 50 Hz Y

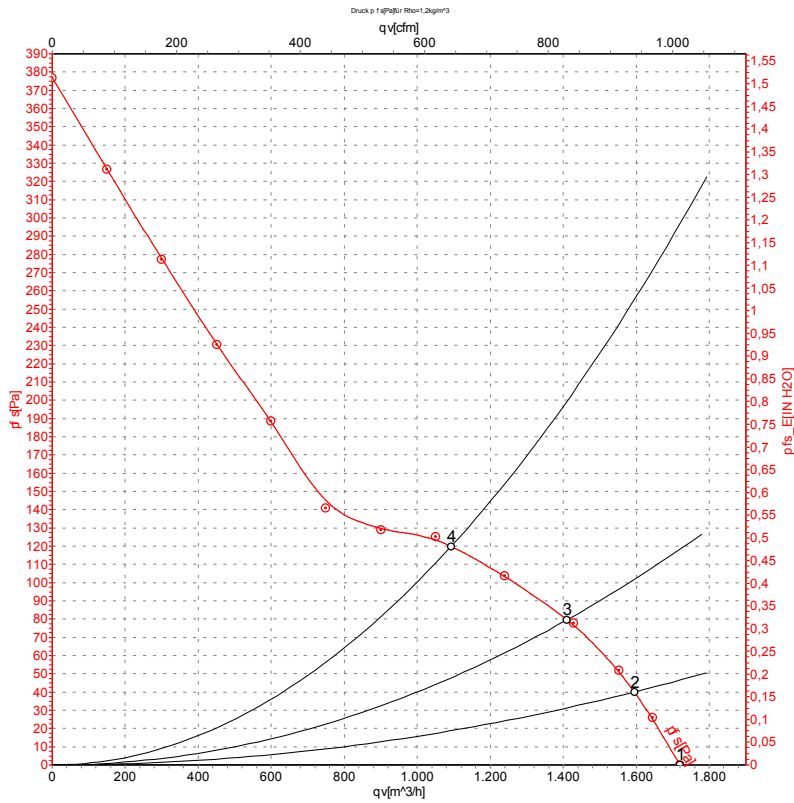

Measurement: LU-69121

Air performance measured as per ISO 5801 Installation category A. For detailed information on the measuring set-up, please contact ebm-papst. Suction-side noise levels: L_{wA} measured as per ISO 13347 / L_{pA} measured with 1m distance to fan axis. The values given are valid under the measuring conditions mentioned above and may vary according to the actual installation situation. With any deviation from the standard set-up, the specific values have to be checked and reviewed with the unit installed.

Measured values

	Conn.	U	f	n	P _e	I	qv	p _{fs}
		V	Hz	min ⁻¹	W	A	m ³ /h	Pa
1	Y	400	50	2650	110	0.22	1720	0
2	Y	400	50	2620	126	0.23	1595	40
3	Y	400	50	2600	131	0.24	1410	80
4	Y	400	50	2595	131	0.24	1090	120

Conn. = Connection · U = Supply voltage · f = Frequency · n = Speed · P_e = Power input · I = Current draw · qv = Air flow · p_{fs} = Pressure increase



AC axial fan

straight blades (A series)
with full square nozzle

Charts: Air flow 60 Hz Y

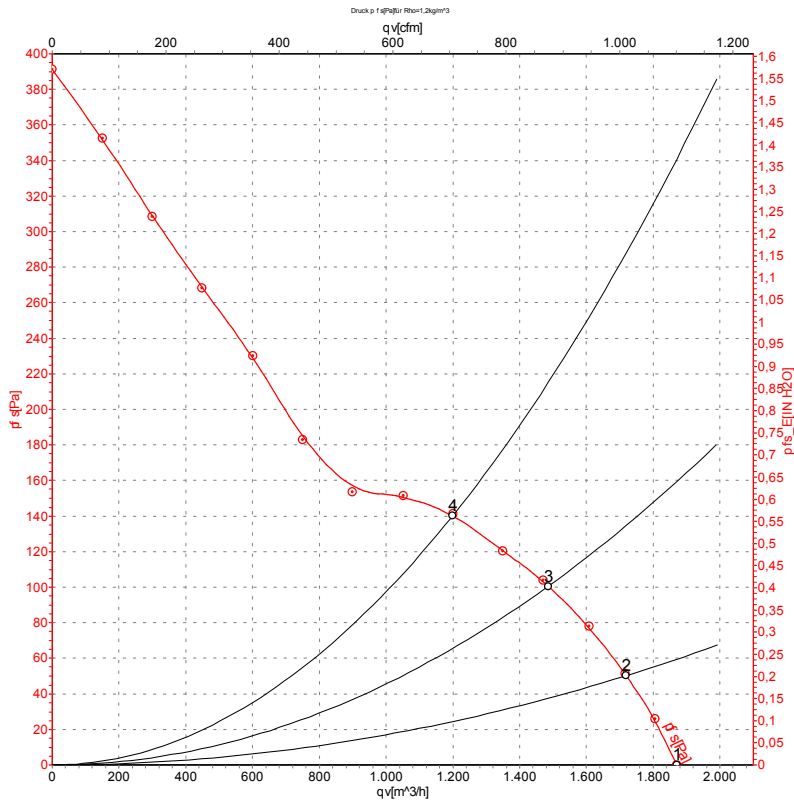

Measurement: LU-69123

Air performance measured as per ISO 5801 Installation category A. For detailed information on the measuring set-up, please contact ebm-papst. Suction-side noise levels: L_{wA} measured as per ISO 13347 / L_{pA} measured with 1m distance to fan axis. The values given are valid under the measuring conditions mentioned above and may vary according to the actual installation situation. With any deviation from the standard set-up, the specific values have to be checked and reviewed with the unit installed.

Measured values

	Conn.	U	f	n	P _e	I	qv	p _{fs}
		V	Hz	min ⁻¹	W	A	m ³ /h	Pa
1	Y	400	60	2950	160	0.26	1870	0
2	Y	400	60	2850	177	0.28	1720	50
3	Y	400	60	2810	184	0.29	1485	100
4	Y	400	60	2805	184	0.29	1200	140

Conn. = Connection · U = Supply voltage · f = Frequency · n = Speed · P_e = Power input · I = Current draw · qv = Air flow · p_{fs} = Pressure increase

