

S4E350-AP06-30

# AC axial fan

sickled blades (S series)  
with guard grille for short nozzle



## ASIA PACIFIC SHENGRUI LIMITED

Phone +00852 56261528  
info@apacfan.com  
www.apacfan.com



### Nominal data

Type	S4E350-AP06-30		
Motor	M4E074-DF		
Phase		1~	1~
Nominal voltage	VAC	230	230
Frequency	Hz	50	60
Type of data definition		fa	fa
Valid for approval / standard		CE	CE
Speed	min <sup>-1</sup>	1400	1590
Power input	W	130	190
Current draw	A	0.58	0.83
Motor capacitor	µF	4	4
Capacitor voltage	VDB	400	400
Max. back pressure	Pa	90	60
Min. ambient temperature	°C	-25	-25
Max. ambient temperature	°C	55	55
Starting current	A	1.2	1.1

ml = Max. load · me = Max. efficiency · fa = Running at free air · cs = Customer specs · cu = Customer unit  
Subject to alterations

### Data according to ErP directive

Installation category	A
Efficiency category	Static
Variable speed drive	No
Specific ratio*	1.00

\* Specific ratio =  $1 + p_g / 100\,000\text{ Pa}$

		Actual	Request 2013	Request 2015
Overall efficiency $\eta_{es}$	%	28.5	24.5	28.5
Efficiency grade N		40	36	40
Power input $P_e$	kW	0.15		
Air flow $q_v$	m <sup>3</sup> /h	2200		
Pressure increase $p_{fs}$	Pa	70		
Speed n	min <sup>-1</sup>	1345		

Data definition with optimum efficiency. LU-31089  
The ErP data is determined using a motor-impeller combination in a standardised measurement configuration.



# AC axial fan

sickled blades (S series)  
with guard grille for short nozzle

## Technical features

<b>Mass</b>	5 kg
<b>Size</b>	350 mm
<b>Surface of rotor</b>	Coated in black
<b>Material of blades</b>	Aluminium sheet, coated in black
<b>Material of guard grille</b>	Steel, phosphated and coated in black plastic
<b>Number of blades</b>	5
<b>Direction of air flow</b>	"V"
<b>Direction of rotation</b>	Counter-clockwise, seen on rotor
<b>Type of protection</b>	IP 44; Depending on installation and position as per EN 60034-5
<b>Insulation class</b>	"F"
<b>Humidity class</b>	F1-2
<b>Max. permissible ambient motor temp. (transp./ storage)</b>	+ 80 °C
<b>Min. permissible ambient motor temp. (transp./storage)</b>	- 40 °C
<b>Mounting position</b>	Shaft horizontal or rotor on bottom; rotor on top on request
<b>Operation mode</b>	S1
<b>Motor bearing</b>	Ball bearing
<b>Touch current acc. IEC 60990 (measuring network Fig. 4, TN system)</b>	< 0.75 mA
<b>Motor protection</b>	Thermal overload protector (TOP) wired internally
<b>Cable exit</b>	Variable
<b>Protection class</b>	I (if protective earth is connected by customer)
<b>Product conforming to standard</b>	EN 60335-1; CE
<b>Approval</b>	CCC; EAC



# AC axial fan

sickled blades (S series)  
with guard grille for short nozzle

## Product drawing

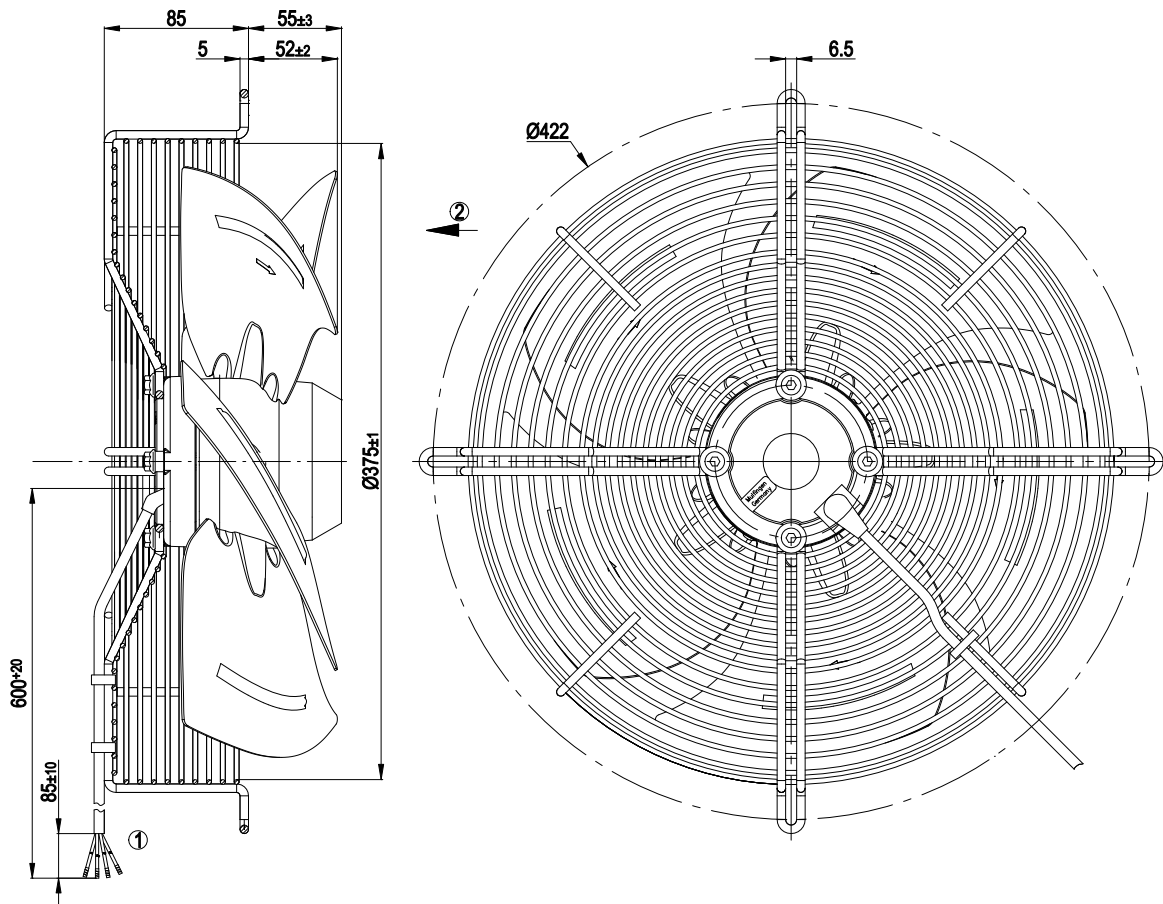

- 1 Connection line silicone 4G 0.5 mm<sup>2</sup>, 4 x brass lead tips crimped
- 2 Direction of air flow "V"

## Connection screen

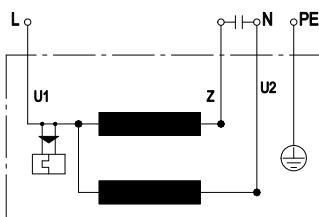

U1	blue	Z	brown	U2	black
PE	green/yellow				



# AC axial fan

sickled blades (S series)  
with guard grille for short nozzle

## Charts: Air flow 50 Hz

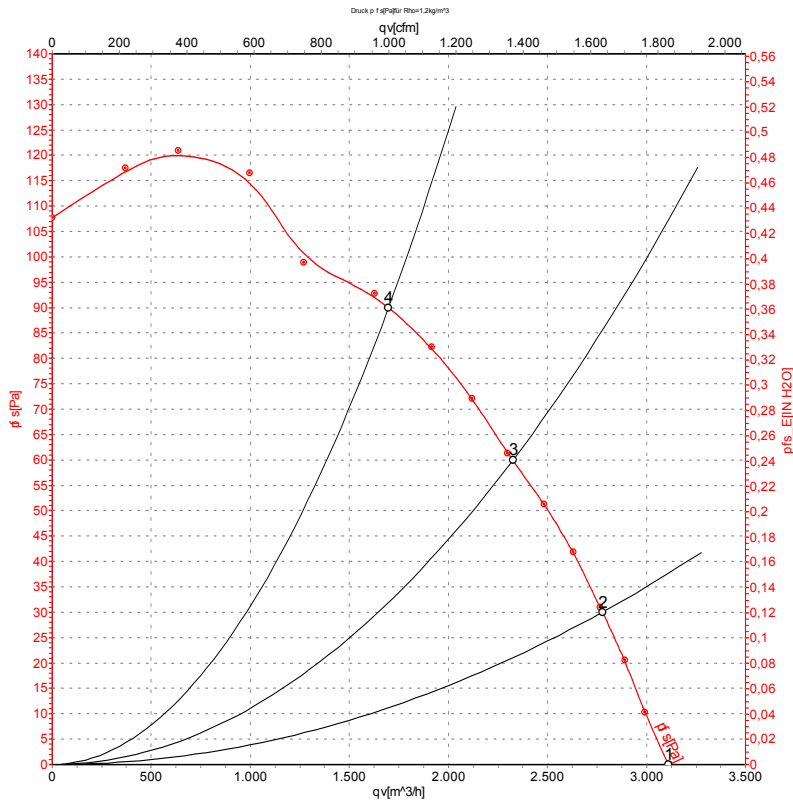

Air performance measured as per ISO 5801 Installation category A. For detailed information on the measuring set-up, please contact ebmpapst. Suction-side noise levels: L<sub>wA</sub> measured as per ISO 13347 / L<sub>pA</sub> measured with 1m distance to fan axis. The values given are valid under the measuring conditions mentioned above and may vary according to the actual installation situation. With any deviation from the standard set-up, the specific values have to be checked and reviewed with the unit installed.

## Measured values

	U	f	n	P <sub>e</sub>	I	qv	P <sub>fs</sub>
	V	Hz	min <sup>-1</sup>	W	A	m³/h	Pa
1	230	50	1400	130	0.58	3110	0
2	230	50	1380	140	0.61	2780	30
3	230	50	1355	151	0.66	2325	60
4	230	50	1290	174	0.76	1700	90

U = Supply voltage · f = Frequency · n = Speed · P<sub>e</sub> = Power input · I = Current draw · qv = Air flow · P<sub>fs</sub> = Pressure increase



# AC axial fan

sickled blades (S series)  
with guard grille for short nozzle

## Charts: Air flow 60 Hz

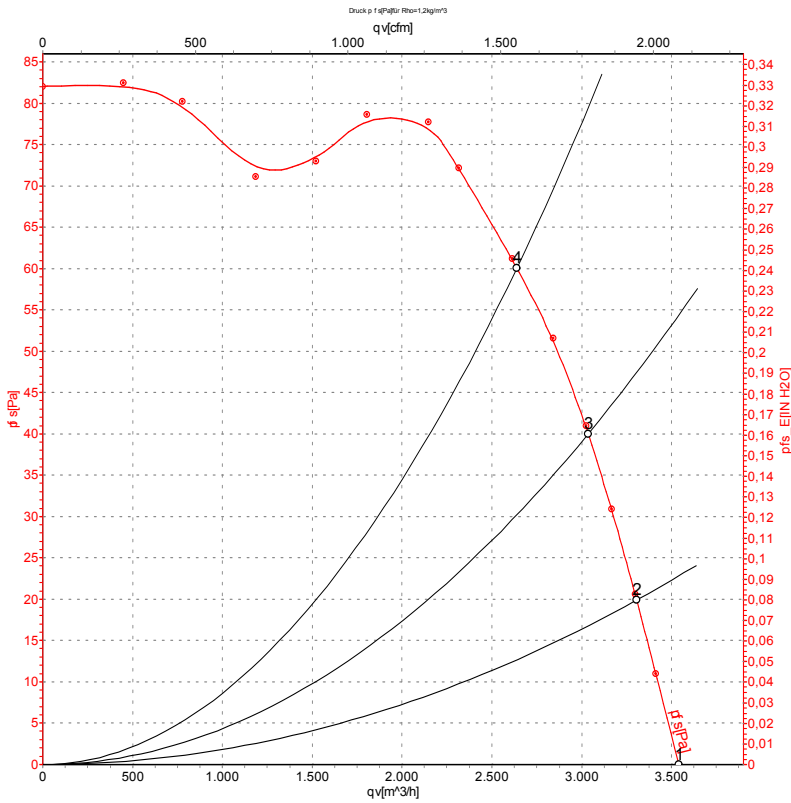

Air performance measured as per ISO 5801 Installation category A. For detailed information on the measuring set-up, please contact ebmpapst. Suction-side noise levels: LwA measured as per ISO 13347 / LpA measured with 1m distance to fan axis. The values given are valid under the measuring conditions mentioned above and may vary according to the actual installation situation. With any deviation from the standard set-up, the specific values have to be checked and reviewed with the unit installed.

## Measured values

	U	f	n	P <sub>e</sub>	I	qv	P <sub>fs</sub>
	V	Hz	min <sup>-1</sup>	W	A	m <sup>3</sup> /h	Pa
1	230	60	1590	190	0.83	3540	0
2	230	60	1565	196	0.85	3305	20
3	230	60	1520	203	0.88	3035	40
4	230	60	1455	208	0.90	2640	60

U = Supply voltage · f = Frequency · n = Speed · P<sub>e</sub> = Power input · I = Current draw · qv = Air flow · P<sub>fs</sub> = Pressure increase

