

AC axial fan

sickled blades (S series)

with guard grille for short nozzle

ebm-papst ventilator (Shanghai)Co.,Ltd.

No.418, Hua Jing Road, Wai Gao Qiao Free Trade Zone, Pudong

Tel: +86(0)21-50460183

www.ebmpapst.com

Nominal data

Type	S4D350-AP08-30/A06				
Motor	M4D074-DF				
Phase		3~	3~	3~	3~
Nominal voltage	VAC	230	230	400	400
Connection		Δ	Δ	Y	Y
Frequency	Hz	50	60	50	60
Type of data definition		fa	fa	fa	fa
Valid for approval / standard		CCC	CCC	CCC	CCC
Speed	min ⁻¹	1410	1600	1410	1600
Power input	W	130	180	130	180
Current draw	A	0.61	0.59	0.35	0.34
Max. back pressure	Pa	90	90	90	90
Max. ambient temperature	°C	50	40	50	40

ml = max. load · me = max. efficiency · fa = running at free air · cs = customer specs · cu = customer unit
Subject to alterations

Data according to ErP directive

Installation category	A	Overall efficiency η_{es}	Actual	Request 2013	Request 2015
Efficiency category	Static	Efficiency grade N	30.7	24.5	28.5
Variable speed drive	No	Power input P_e	42.2	36	40
Specific ratio*	1.00	Power input P_e	kW	0.15	
		Air flow q_v	m ³ /h	2110	
		Pressure increase p_{fs}	Pa	80	
		Speed n	min ⁻¹	1385	

Data established at point of optimum efficiency



AC axial fan

sickled blades (S series)
with guard grille for short nozzle

Technical features

Mass	4.6 kg
Size	350 mm
Surface of rotor	Coated in black
Material of blades	Sheet steel, coated in black
Guard grille material	Steel, coated with black plastic (RAL 9005)
Number of blades	5
Direction of rotation	"V"
Type of protection	IP 44; Depending on installation and position as per EN 60034-5
Insulation class	"B"
Max. permissible ambient motor temp. (transp./ storage)	+ 80 °C
Min. permissible ambient motor temp. (transp./storage)	- 40 °C
Mounting position	Shaft horizontal or rotor on bottom; rotor on top on request
Condensate discharge holes	Rotor-side
Operation mode	S1
Motor bearing	Ball bearing
Touch current acc. IEC 60990 (measuring network Fig. 4, TN system)	< 0.75 mA
Cable exit	Variable
Protection class	I (if protective earth is connected by customer)
Product conforming to standard	EN 60335-1

AC axial fan

sickled blades (S series)

with guard grille for short nozzle

Product drawing

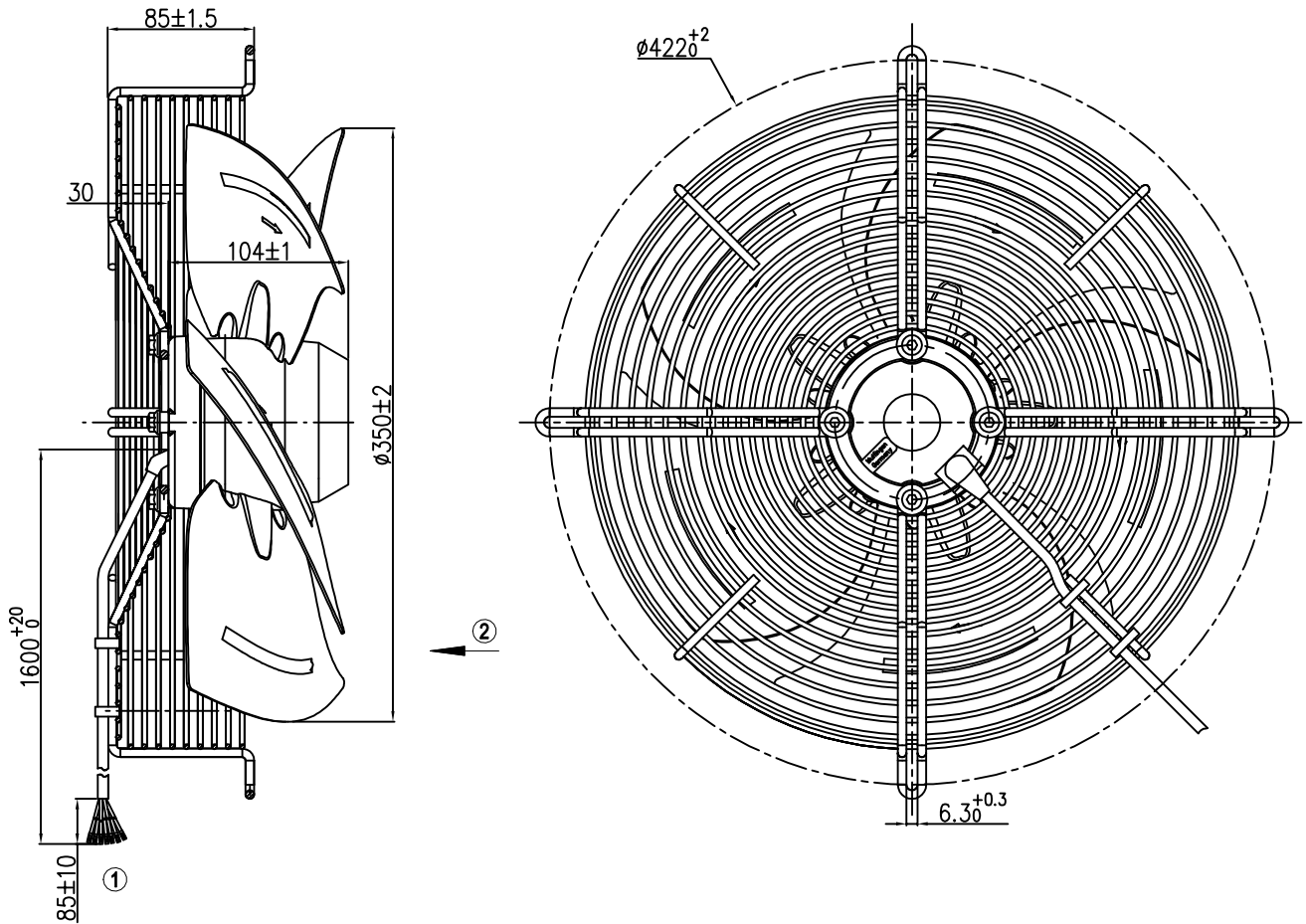

- | | |
|---|---|
| 1 | Connection line PVC 7G 0.5 mm ² , 7x brass lead tips crimped |
| 2 | Direction of air flow "V" |

AC axial fan

sickled blades (S series)

with guard grille for short nozzle

Connection screen

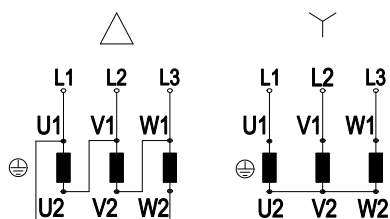

Note: Direction of rotation changes when two phases are reversed

Δ	Delta connection	Y	Star connection	L1	black
L2	blue	L3	brown	U1	black
V1	blue	W1	brown	U2	green
V2	white	W2	yellow		

AC axial fan

sickled blades (S series)
with guard grille for short nozzle

Charts: Air flow 50 Hz

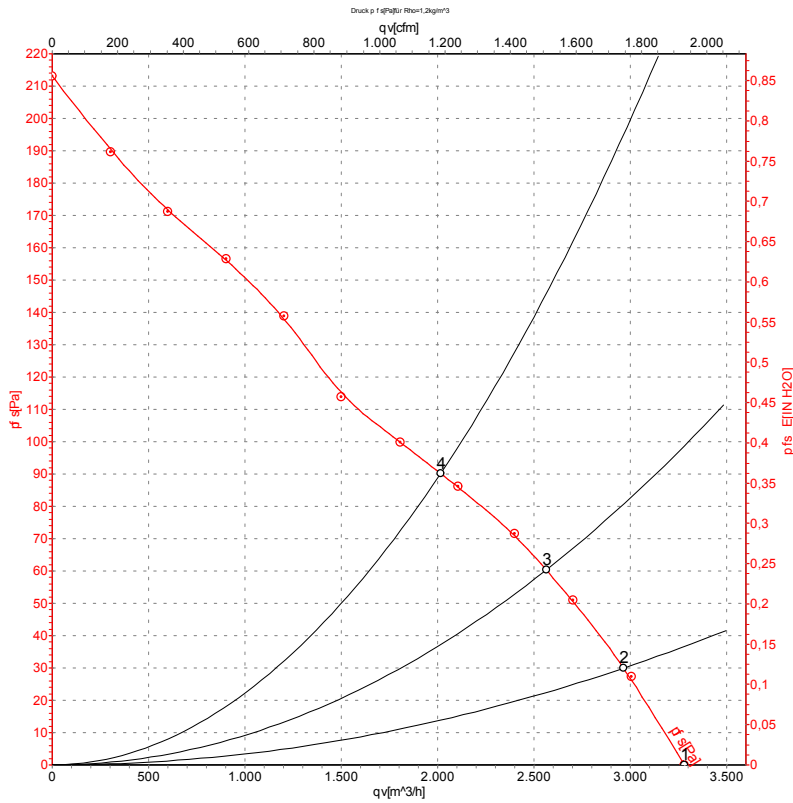

Measurement: LU-122615

Air performance measured as per ISO 5801 Installation category A. For detailed information on the measuring set-up, please contact ebm-papst. Suction-side noise levels: LwA measured as per ISO 13347 / LpA measured with 1m distance to fan axis. The values given are valid under the measuring conditions mentioned above and may vary according to the actual installation situation. With any deviation from the standard set-up, the specific values have to be checked and reviewed with the unit installed.

Measured values

	Conn.	U	f	n	Pe	I	qv	pfs
		V	Hz	min ⁻¹	W	A	m ³ /h	Pa
1	Y	400	50	1410	130	0.35	3280	0
2	Y	400	50	1395	145	0.35	2965	30
3	Y	400	50	1380	158	0.36	2565	60
4	Y	400	50	1355	179	0.38	2015	90

Conn. = Connection · U = Supply voltage · f = Frequency · n = Speed · Pe = Power input · I = Current draw · qv = Air flow · pfs = Pressure increase



AC axial fan

sickled blades (S series)
with guard grille for short nozzle

Charts: Air flow 60 Hz

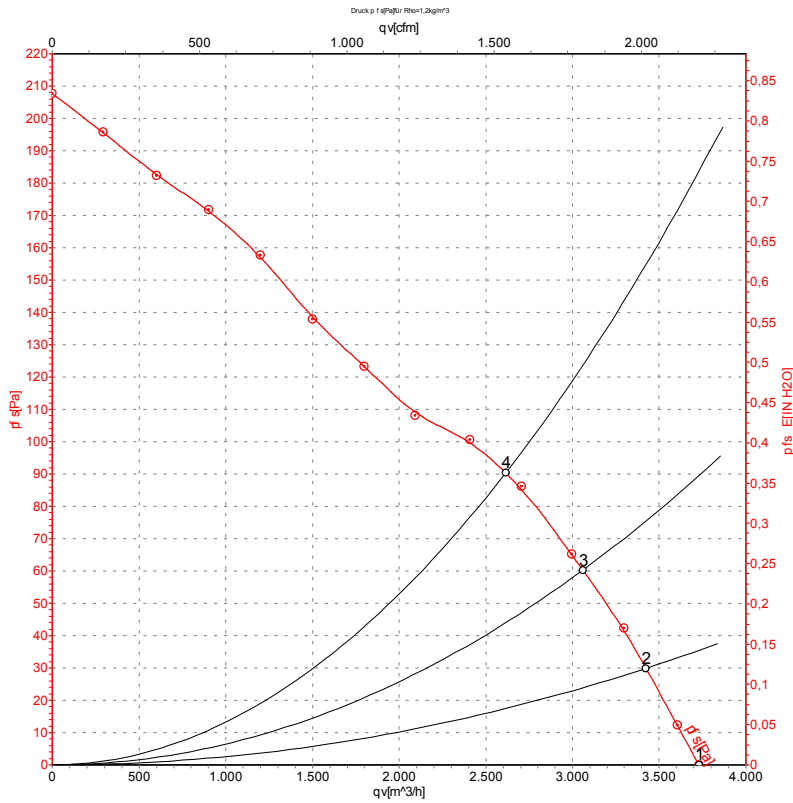

Measurement: LU-122616

Air performance measured as per ISO 5801 Installation category A. For detailed information on the measuring set-up, please contact ebm-papst. Suction-side noise levels: L_{wA} measured as per ISO 13347 / L_{pA} measured with 1m distance to fan axis. The values given are valid under the measuring conditions mentioned above and may vary according to the actual installation situation. With any deviation from the standard set-up, the specific values have to be checked and reviewed with the unit installed.

Measured values

	Conn.	U	f	n	P _e	I	qv	p _{fs}
		V	Hz	min ⁻¹	W	A	m ³ /h	Pa
1	Y	400	60	1600	180	0.34	3730	0
2	Y	400	60	1585	196	0.35	3425	30
3	Y	400	60	1555	214	0.37	3060	60
4	Y	400	60	1525	232	0.40	2615	90

Conn. = Connection · U = Supply voltage · f = Frequency · n = Speed · P_e = Power input · I = Current draw · qv = Air flow · p_{fs} = Pressure increase

