

S3G500-AM56-21

EC axial fan - HyBlade®

sickled blades (S series)

with guard grille for short nozzle



ASIA PACIFIC SHENGRUI LIMITED

Phone +00852 56261528

info@apacfan.com

www.apacfan.com



Nominal data

Type	S3G500-AM56-21	
Motor	M3G112-EA	
Phase		1~
Nominal voltage	VAC	230
Nominal voltage range	VAC	200 .. 277
Frequency	Hz	50/60
Type of data definition		ml
Speed	min ⁻¹	1420
Power input	W	750
Current draw	A	3.4
Max. back pressure	Pa	175
Min. ambient temperature	°C	-25
Max. ambient temperature	°C	+60

ml = Max. load · me = Max. efficiency · fa = Running at free air · cs = Customer specs · cu = Customer unit
Subject to alterations

Data according to ErP directive

Installation category	A
Efficiency category	Static
Variable speed drive	Yes
Specific ratio*	1.00

* Specific ratio = $1 + p_b / 100\,000\text{ Pa}$

	Actual	Request 2013	Request 2015
Overall efficiency η_{es}	41.6	28.8	32.8
Efficiency grade N	48.8	36	40
Power input P_{ed}	kW	0.73	
Air flow q_v	m ³ /h	5850	
Pressure increase p_{fs}	Pa	173	
Speed n	min ⁻¹	1425	

Data definition with optimum efficiency.



Technical features

Mass	11 kg
Size	500 mm
Surface of rotor	Coated in black
Material of electronics housing	Die-cast aluminium, coated in black
Material of blades	Press-fitted sheet steel blank, sprayed with PP plastic
Material of guard grille	Steel, coated in black plastic (RAL9005)
Number of blades	5
Direction of air flow	"V"
Direction of rotation	Counter-clockwise, seen on rotor
Type of protection	IP 54
Insulation class	"B"
Humidity class	F4-1
Max. permissible ambient motor temp. (transp./ storage)	+ 80 °C
Min. permissible ambient motor temp. (transp./storage)	- 40 °C
Mounting position	Shaft horizontal or rotor on bottom; rotor on top on request
Condensate discharge holes	Rotor-side
Operation mode	S1
Motor bearing	Ball bearing
Technical features	<ul style="list-style-type: none"> - Output 10 VDC, max. 10 mA - Alarm relay - Motor current limit - PFC, active - Soft start - Control input 0-10 VDC Control interface with SELV potential safely disconnected from the mains - Over-temperature protected electronics / motor - Line undervoltage / phase failure detection
EMC interference immunity	Acc. to EN 61000-6-2 (industrial environment)
EMC harmonics	Acc. to EN 61000-3-2/3
EMC interference emission	Acc. to EN 61000-6-4 (industrial environment)
Touch current acc. IEC 60990 (measuring network Fig. 4, TN system)	<= 3.5 mA
Motor protection	Thermal overload protector (TOP) wired internally
Cable exit	Variable
Protection class	I (if protective earth is connected by customer)
Product conforming to standard	EN 61800-5-1; CE
Approval	CCC; GOST

EC axial fan - HyBlade®

sickled blades (S series)

with guard grille for short nozzle

Product drawing

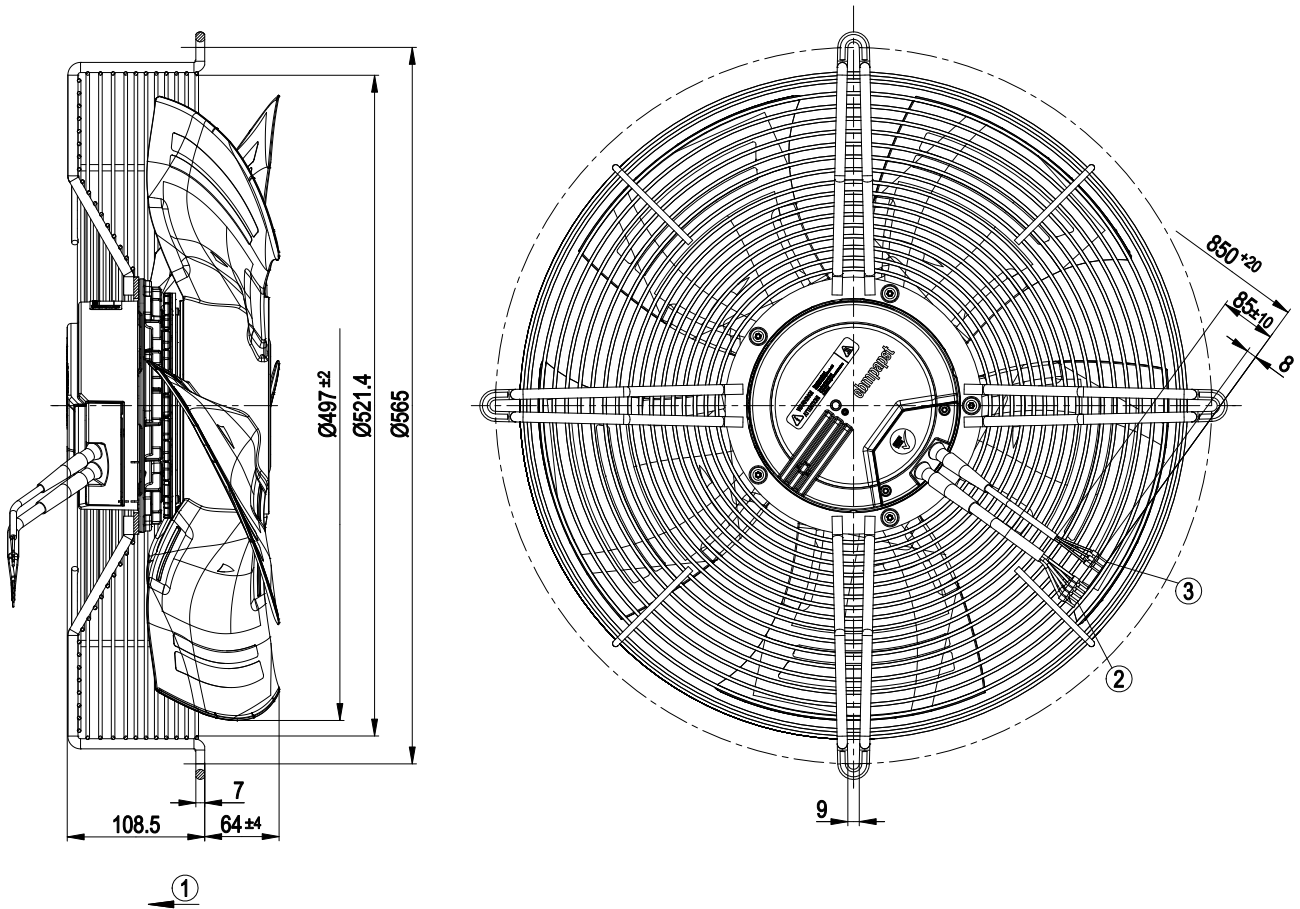

- | | |
|---|---|
| 1 | Direction of air flow "V" |
| 2 | Connection line PVC AWG 18, 5x crimped core-end sleeves |
| 3 | Connection line PVC AWG 22, 3x crimped core-end sleeve |

Connection screen

Customer circuit

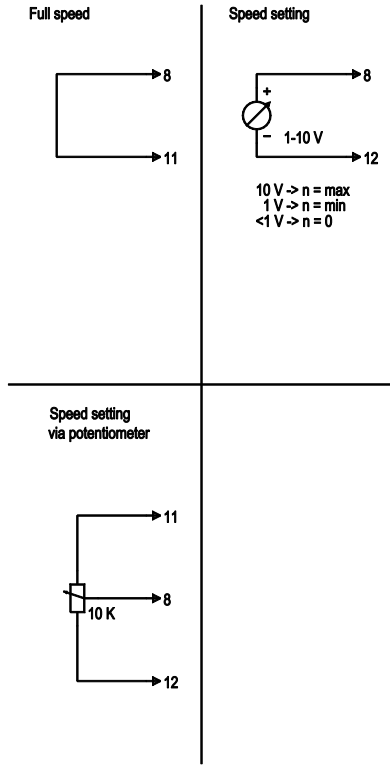

Connection

Fan / motor

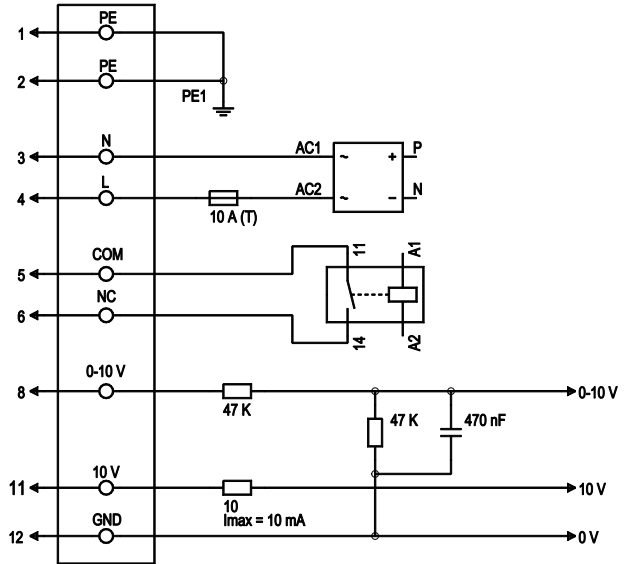

Line	No.	Signal	Colour	Function / assignment
1	1,2	PE	green/yellow	Protective earth
1	3	N	blue	Supply voltage, neutral conductor, 50/60 Hz
1	4	L	black	Supply voltage, phase, 50/60 Hz
1	5	COM	white 1	Floating status message contact, break for failure (2 A, max. 250 VAC, min. 10 mA, AC1)
1	6	NC	white 2	Floating status message contact, break for failure
2	8	0-10 V	yellow	Control input, set value 0-10 VDC, impedance 100 kΩ, SELV
2	11	10 VDC	red	Voltage output 10 VDC (+/-3%), max. 10 mA, supply voltage for external devices (e.g. potentiometer), SELV
2	12	GND	blue	Reference mass for control interface, SELV

Charts: Air flow 50 Hz

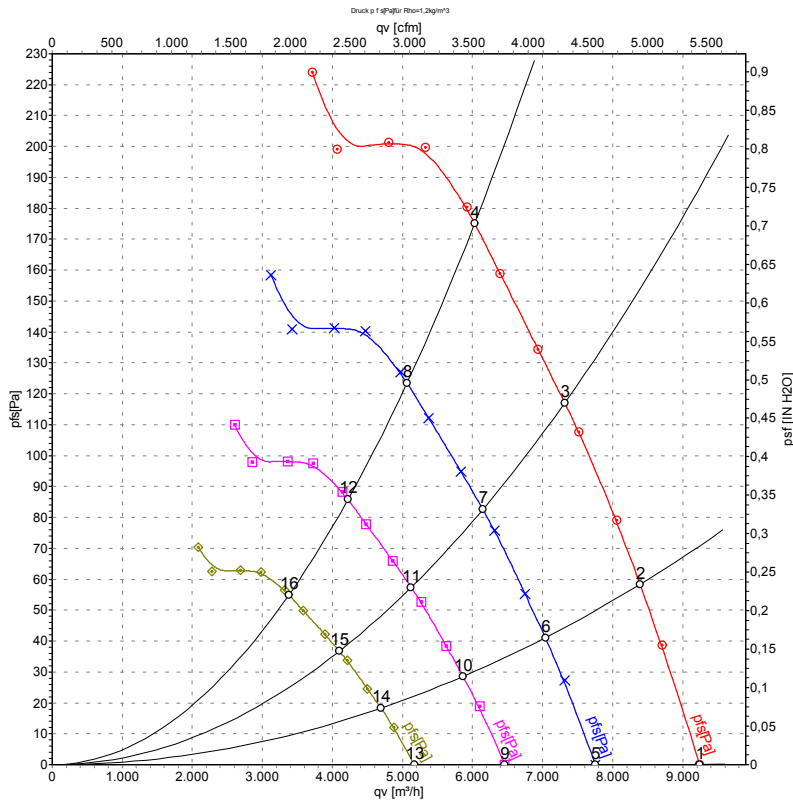

Measurement: LU-131222

Air performance measured as per ISO 5801 Installation category A. For detailed information on the measuring set-up, please contact ebmpapst. Suction-side noise levels: LwA measured as per ISO 13347 / LpA measured with 1m distance to fan axis. The values given are valid under the measuring conditions mentioned above and may vary according to the actual installation situation. With any deviation from the standard set-up, the specific values have to be checked and reviewed with the unit installed.

Measured values

	U	f	n	P _{ed}	I	LpA _{in}	LwA _{in}	LwA _{out}	qv	p _{fs}
	V	Hz	min ⁻¹	W	A	dB(A)	dB(A)	dB(A)	m ³ /h	Pa
1	230	50	1420	554	2.52	70	77	77	9245	0
2	230	50	1420	633	2.85	67	75	75	8390	58
3	230	50	1420	696	3.12	66	73	73	7315	117
4	230	50	1420	750	3.40	66	74	73	6030	175
5	230	50	1200	327	1.49	66	74	74	7755	0
6	230	50	1200	373	1.68	64	71	71	7040	41
7	230	50	1200	413	1.85	62	69	69	6145	83
8	230	50	1200	443	1.97	62	70	70	5065	124
9	230	50	1000	189	0.86	62	70	70	6460	0
10	230	50	1000	216	0.97	60	67	67	5865	28
11	230	50	1000	239	1.07	58	65	65	5125	57
12	230	50	1000	256	1.14	58	66	66	4220	86
13	230	50	800	97	0.44	58	65	65	5170	0
14	230	50	800	111	0.50	55	62	62	4695	18
15	230	50	800	122	0.55	53	60	60	4100	37
16	230	50	800	131	0.59	54	61	61	3375	55

U = Supply voltage · f = Frequency · n = Speed · P_{ed} = Power input · I = Current draw · LpA_{in} = Sound pressure level inlet side · LwA_{in} = Sound power level inlet side · LwA_{out} = Sound power level outlet side
 qv = Air flow · p_{fs} = Pressure increase

