

AC centrifugal fan

backward curved, single inlet



ASIA PACIFIC SHENGRUI LIMITED

Phone +00852 56261528

info@apacfan.com

www.apacfan.com



Nominal data

Type	R4E355-AK05-12		
Motor	M4E074-EI		
Phase		1~	1~
Nominal voltage	VAC	230	230
Frequency	Hz	50	60
Type of data definition		fa	fa
Valid for approval / standard		CE	CE
Speed	min ⁻¹	1400	1600
Power input	W	180	260
Current draw	A	0.8	1.14
Motor capacitor	μF	6	6
Capacitor voltage	VDB	450	450
Min. back pressure	Pa	0	
Min. ambient temperature	°C	-25	-25
Max. ambient temperature	°C	60	35
Starting current	A	1.95	1.8

ml = Max. load · me = Max. efficiency · fa = Running at free air · cs = Customer specs · cu = Customer unit
Subject to alterations

Data according to ErP directive

Installation category	A
Efficiency category	Static
Variable speed drive	No
Specific ratio*	1.00

* Specific ratio = $1 + p_g / 100\,000\text{ Pa}$

	Actual	Request 2013	Request 2015
Overall efficiency η_{es}	40.9	40.8	44.8
Efficiency grade N	58.1	58	62
Power input P_e	kW	0.23	
Air flow q_v	m ³ /h	1730	
Pressure increase p_{fs}	Pa	201	
Speed n	min ⁻¹	1325	

Data established at point of optimum efficiency



AC centrifugal fan

backward curved, single inlet

Technical features

Mass	4.7 kg
Size	355 mm
Surface of rotor	Acid protection, coated in black with condensation drain holes
Material of impeller	Aluminum sheet, laser-welded
Number of blades	6
Direction of rotation	Clockwise, seen on rotor
Type of protection	IP 44; Depending on installation and position as per EN 60034-5
Insulation class	"F"
Humidity class	F1-2
Max. permissible ambient motor temp. (transp./ storage)	+ 80 °C
Min. permissible ambient motor temp. (transp./storage)	- 40 °C
Mounting position	Shaft horizontal or rotor on bottom; rotor on top on request
Condensate discharge holes	Rotor-side
Operation mode	S1
Motor bearing	Ball bearing
Touch current acc. IEC 60990 (measuring network Fig. 4, TN system)	< 0.75 mA
Motor protection	Thermal overload protector (TOP) brought out
Cable exit	Variable
Protection class	I (if protective earth is connected by customer)
Product conforming to standard	EN 60335-1; CE
Approval	CCC

AC centrifugal fan

backward curved, single inlet

Product drawing

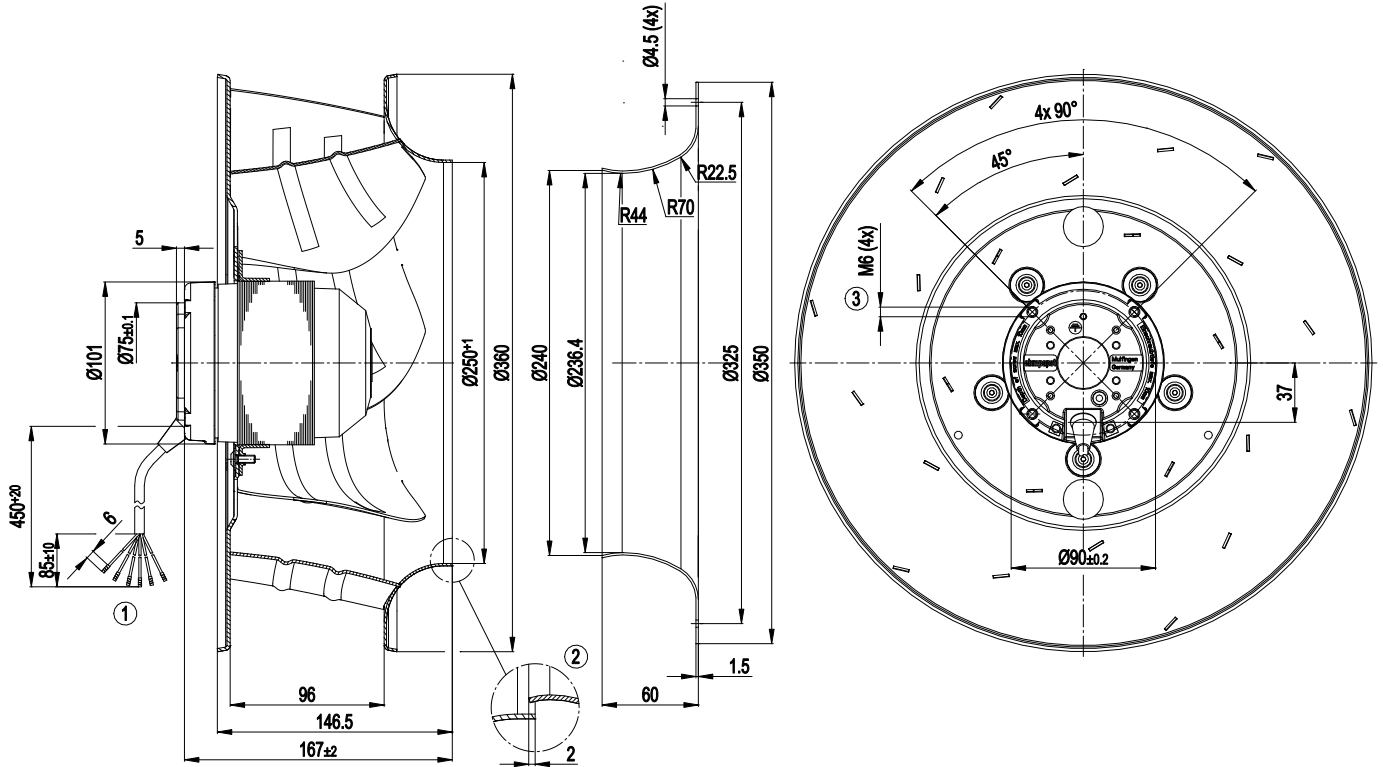

1	Connection line silicone 6G 0.5 mm ² , 6 x brass lead tips crimped
2	Accessory part: Inlet nozzle 35560-2-4013, not included in the standard scope of delivery
3	Depth of screw max. 10 mm

Connection screen

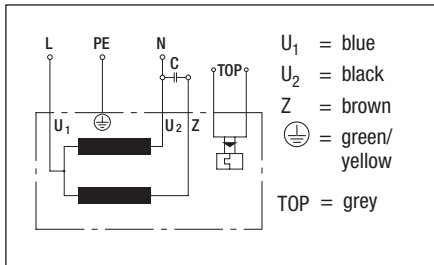

AC centrifugal fan

backward curved, single inlet

Charts: Air flow 50 Hz

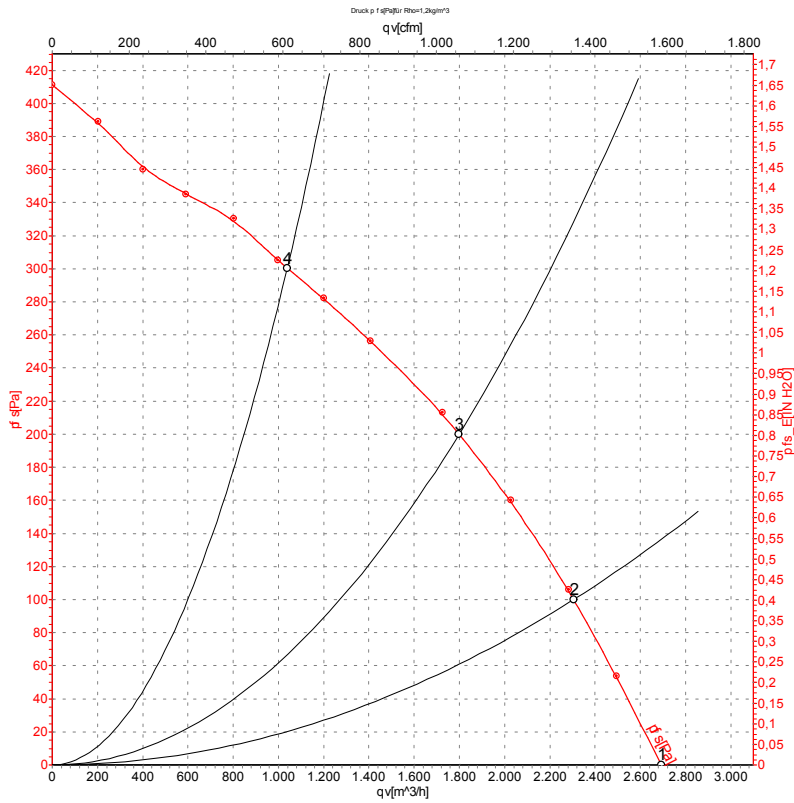

Measurement: LU-106554

Air performance measured as per ISO 5801 Installation category A. For detailed information on the measuring set-up, please contact ebm-papst. Suction-side noise levels: LwA measured as per ISO 13347 / LpA measured with 1m distance to fan axis. The values given are valid under the measuring conditions mentioned above and may vary according to the actual installation situation. With any deviation from the standard set-up, the specific values have to be checked and reviewed with the unit installed.

Measured values

	U	f	n	P _e	I	qv	P _{fs}
	V	Hz	min ⁻¹	W	A	m ³ /h	Pa
1	230	50	1400	180	0.80	2695	0
2	230	50	1355	218	0.96	2305	100
3	230	50	1330	234	1.03	1800	200
4	230	50	1350	221	0.98	1040	300

U = Supply voltage · f = Frequency · n = Speed · P_e = Power input · I = Current draw · qv = Air flow · P_{fs} = Pressure increase



AC centrifugal fan

backward curved, single inlet

Charts: Air flow 60 Hz

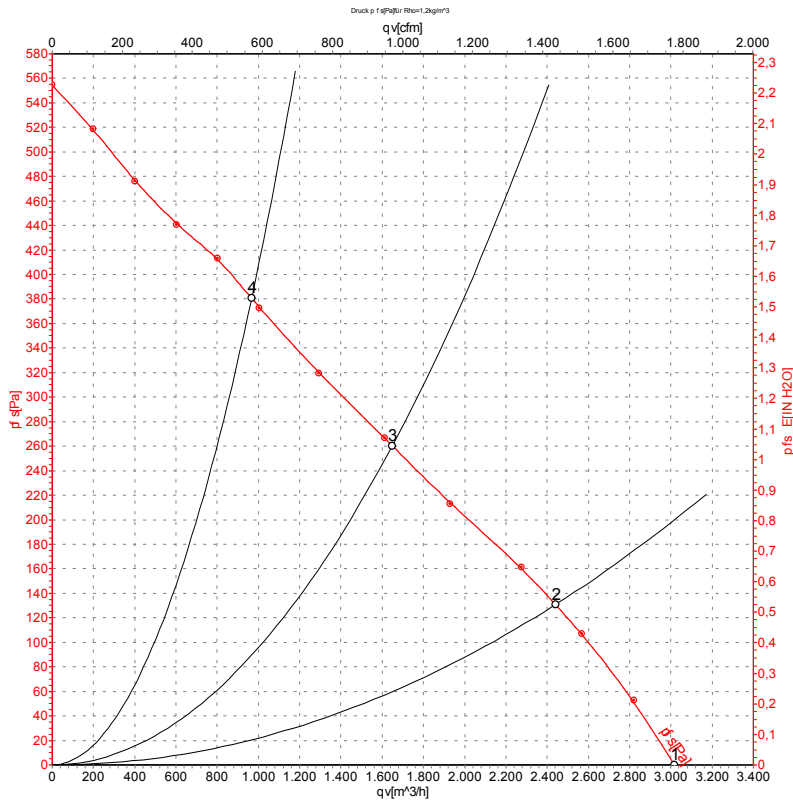

Measurement: LU-106556

Air performance measured as per ISO 5801 Installation category A. For detailed information on the measuring set-up, please contact ebm-papst. Suction-side noise levels: L_{wA} measured as per ISO 13347 / L_{pA} measured with 1m distance to fan axis. The values given are valid under the measuring conditions mentioned above and may vary according to the actual installation situation. With any deviation from the standard set-up, the specific values have to be checked and reviewed with the unit installed.

Measured values

	U	f	n	P _e	I	qv	P _{fs}
	V	Hz	min ⁻¹	W	A	m ³ /h	Pa
1	230	60	1600	260	1.14	3020	0
2	230	60	1465	316	1.37	2440	130
3	230	60	1395	329	1.43	1650	260
4	230	60	1485	309	1.34	965	380

U = Supply voltage · f = Frequency · n = Speed · P_e = Power input · I = Current draw · qv = Air flow · P_{fs} = Pressure increase

