

R4D450-AK01-01

AC centrifugal fan

backward curved, single inlet



ASIA PACIFIC SHENGRUI LIMITED

Phone +00852 56261528

info@apacfan.com

www.apacfan.com



Nominal data

Type	R4D450-AK01-01				
Motor	M4D110-GF				
Phase		3~	3~	3~	3~
Nominal voltage	VAC	230	230	400	400
Connection		Δ	Δ	Y	Y
Frequency	Hz	50	60	50	60
Type of data definition		ml	ml	ml	ml
Valid for approval / standard		CE	CE	CE	CE
Speed	min ⁻¹	1350	1490	1350	1490
Power input	W	740	1090	740	1090
Current draw	A	2.6	3.32	1.5	1.92
Min. back pressure	Pa	0	0	0	0
Min. ambient temperature	°C	-40	-40	-40	-40
Max. ambient temperature	°C	80	50	80	50
Starting current	A	17.5	16.8	10	9.6

ml = Max. load · me = Max. efficiency · fa = Running at free air · cs = Customer specs · cu = Customer unit

Subject to alterations

Data according to ErP directive

Installation category	A
Efficiency category	Static
Variable speed drive	No
Specific ratio*	1.00

* Specific ratio = $1 + p_{fs} / 100\,000\text{ Pa}$

		Actual	Request 2013	Request 2015
Overall efficiency η_{es}	%	50	46	50
Efficiency grade N		62	58	62
Power input P_e	kW	0.72		
Air flow q_v	m ³ /h	3515		
Pressure increase p_{fs}	Pa	370		
Speed n	min ⁻¹	1350		

Data definition with optimum efficiency.

The ErP data is determined using a motor-impeller combination in a standardised measurement configuration.

LU-101530



Technical features

Mass	12 kg
Size	450 mm
Surface of rotor	Cast in aluminium
Material of impeller	Aluminium sheet
Number of blades	6
Direction of rotation	Clockwise, seen on rotor
Type of protection	IP 54
Insulation class	"F"
Humidity class	F3-1
Max. permissible ambient motor temp. (transp./ storage)	+ 80 °C
Min. permissible ambient motor temp. (transp./storage)	- 40 °C
Mounting position	Shaft horizontal or rotor on bottom; rotor on top on request
Condensate discharge holes	Rotor-side
Operation mode	S1
Motor bearing	Ball bearing
Touch current acc. IEC 60990 (measuring network Fig. 4, TN system)	<= 3.5 mA
Motor protection	Thermal overload protector (TOP) brought out
Protection class	I (if protective earth is connected by customer)
Product conforming to standard	EN 61800-5-1; CE
Approval	CCC; CSA C22.2 Nr.100; EAC; UL 1004-1; VDE

AC centrifugal fan

backward curved, single inlet

Product drawing

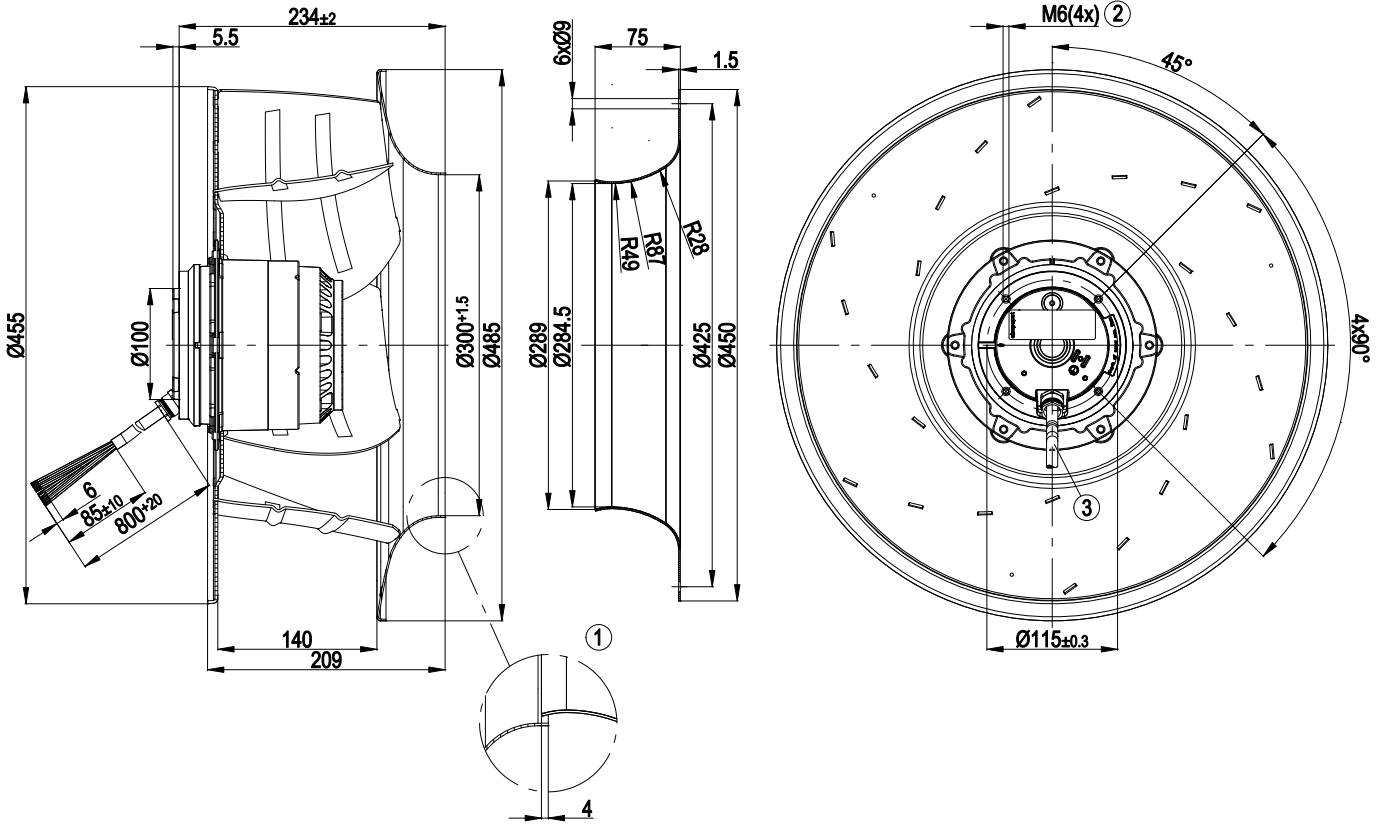

- | | |
|---|--|
| 1 | Accessory part: inlet nozzle 63045-2-4013 not included in the standard scope of delivery; other inlet nozzles on request |
| 2 | Depth of screw max. 12 mm |
| 3 | Connection line silicone 9G0.75 mm ² , 9 x brass lead tips crimped |

Connection screen

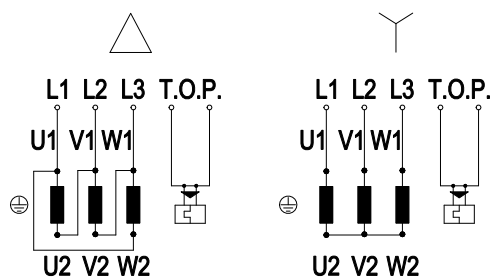

Note: Direction of rotation changes when two phases are reversed

Δ	Delta-connection	Y	Star connection	L1	black
L2	blue	L3	brown	U1	black
V1	blue	W1	brown	U2	green
V2	white	W2	yellow	TOP	grey

Charts: Air flow 50 Hz

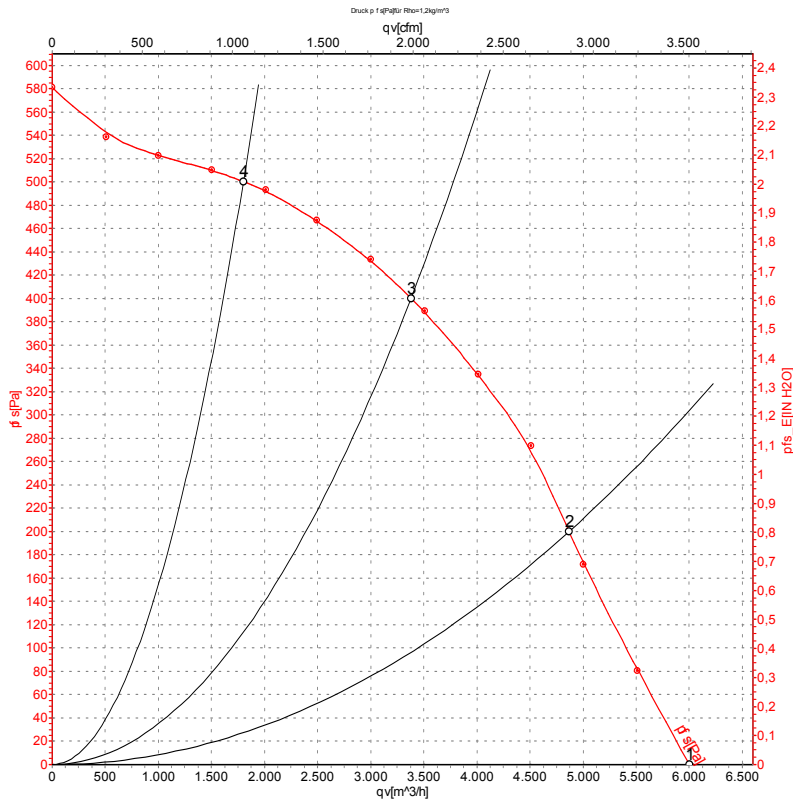

Air performance measured as per ISO 5801 Installation category A. For detailed information on the measuring set-up, please contact ebm-papst. Suction-side noise levels: LwA measured as per ISO 13347 / LpA measured with 1m distance to fan axis. The values given are valid under the measuring conditions mentioned above and may vary according to the actual installation situation. With any deviation from the standard set-up, the specific values have to be checked and reviewed with the unit installed.

Measured values

	Conn.	U	f	n	P _e	I	LpA _{in}	LwA _{in}	qv	p _{fs}
		V	Hz	min ⁻¹	W	A	dB(A)	dB(A)	m ³ /h	Pa
1	Y	400	50	1395	566	1.26	71	79	6000	0
2	Y	400	50	1365	670	1.37	66	75	4870	200
3	Y	400	50	1350	740	1.50	63	70	3380	400
4	Y	400	50	1375	617	1.31	68	76	1800	500

Conn. = Connection · U = Supply voltage · f = Frequency · n = Speed · P_e = Power input · I = Current draw · LpA_{in} = Sound pressure level inlet side · LwA_{in} = Sound power level inlet side
 qv = Air flow · p_{fs} = Pressure increase



Charts: Air flow 60 Hz

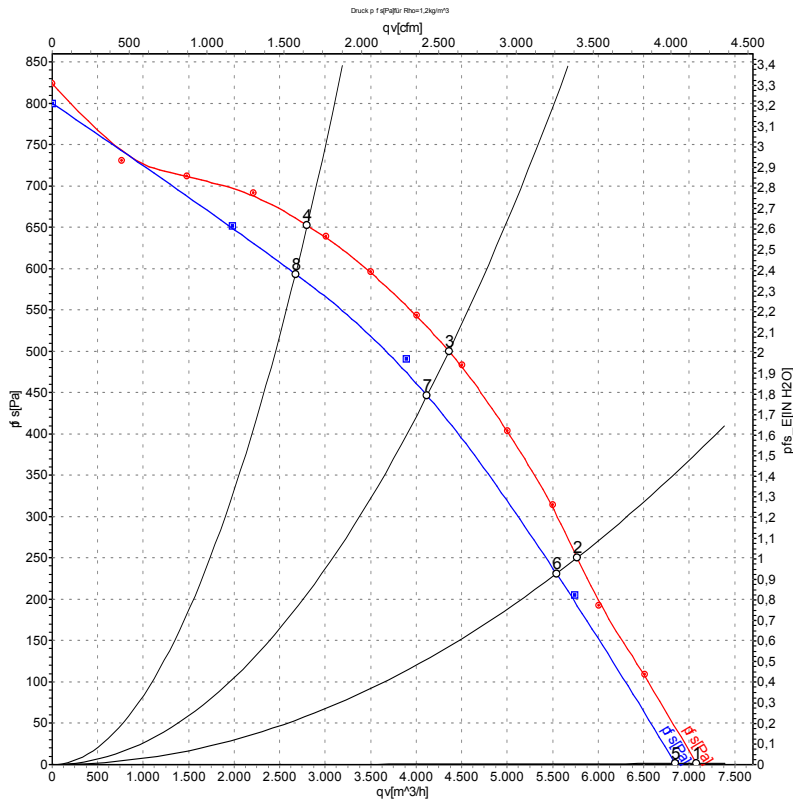

Air performance measured as per ISO 5801 Installation category A. For detailed information on the measuring set-up, please contact ebm-papst. Suction-side noise levels: LwA measured as per ISO 13347 / LpA measured with 1m distance to fan axis. The values given are valid under the measuring conditions mentioned above and may vary according to the actual installation situation. With any deviation from the standard set-up, the specific values have to be checked and reviewed with the unit installed.

Measured values

	Conn.	U	f	n	P _e	I	LpA _{in}	LwA _{in}	qv	p _{fs}
		V	Hz	min ⁻¹	W	A	dB(A)	dB(A)	m ³ /h	Pa
1	Y	480	60	1640	918	1.49	75	83	7080	0
2	Y	480	60	1605	1084	1.67	71	79	5770	250
3	Y	480	60	1580	1200	1.85	67	75	4360	500
4	Y	480	60	1600	1100	1.68	70	78	2800	650
5	Y	400	60	1575	845	1.50	74	82	6845	0
6	Y	400	60	1530	973	1.71	69	77	5540	235
7	Y	400	60	1490	1090	1.92	65	74	4120	456
8	Y	400	60	1530	970	1.67	69	77	2675	594

Conn. = Connection · U = Supply voltage · f = Frequency · n = Speed · P_e = Power input · I = Current draw · LpA_{in} = Sound pressure level inlet side · LwA_{in} = Sound power level inlet side
 qv = Air flow · p_{fs} = Pressure increase

