

ASIA PACIFIC SHENGRUI LIMITED

Phone +00852 56261528

info@apacfan.com

www.apacfan.com

Nominal data

| | | |
|--------------------------|-------------------|------------|
| Type | R3G630-RB32-03 | |
| Motor | M3G150-IF | |
| Phase | | 3~ |
| Nominal voltage | VAC | 400 |
| Nominal voltage range | VAC | 380 .. 480 |
| Frequency | Hz | 50/60 |
| Method of obtaining data | | ml |
| Status | | prelim. |
| Speed (rpm) | min ⁻¹ | 1400 |
| Power consumption | W | 3600 |
| Current draw | A | 5.5 |
| Min. ambient temperature | °C | -40 |
| Max. ambient temperature | °C | 40 |

ml = Max. load · me = Max. efficiency · fa = Free air · cs = Customer specification · ce = Customer equipment
Subject to change

Data according to Commission Regulation (EU) 327/2011

| | | Actual | Req. 2015 | | | |
|-----------------------------------|---|--------|-----------|--------------------------------|-------------------|-------|
| 01 Overall efficiency η_{es} | % | 63.9 | 57.3 | 09 Power consumption P_{ed} | kW | 3.58 |
| 02 Measurement category | | A | | 09 Air flow q_v | m ³ /h | 10895 |
| 03 Efficiency category | | Static | | 09 Pressure increase p_{fs} | Pa | 725 |
| 04 Efficiency grade N | | 68.6 | 62 | 10 Speed (rpm) n | min ⁻¹ | 1405 |
| 05 Variable speed drive | | Yes | | 11 Specific ratio [*] | | 1.01 |

Data obtained at optimum efficiency level.

The ErP data is determined using a motor-impeller combination in a standardized measurement setup.

^{*} Specific ratio = $1 + p_{fs} / 100\,000\text{ Pa}$

LU-181577



Technical description

| | |
|---|--|
| Weight | 29.8 kg |
| Size | 630 mm |
| Motor size | 150 |
| Rotor surface | Painted black |
| Electronics housing material | Die-cast aluminum |
| Impeller material | PP plastic |
| Number of blades | 6 |
| Direction of rotation | Clockwise, viewed toward rotor |
| Degree of protection | IP55 |
| Insulation class | "F" |
| Moisture (F) / Environmental (H) protection class | H1 |
| Ambient temperature note | Occasional start-up at temperatures between -40°C and -25°C is permitted. For continuous operation at ambient temperatures below -25°C (such as refrigeration applications), use must be made of a fan design with special low-temperature bearings. |
| Max. permitted ambient temp. for motor (transport/storage) | +80 °C |
| Min. permitted ambient temp. for motor (transport/storage) | -40 °C |
| Installation position | Shaft horizontal or rotor on bottom; rotor on top on request |
| Condensation drainage holes | On rotor side |
| Mode | S1 |
| Motor bearing | Ball bearing |
| Technical features | <ul style="list-style-type: none"> - Operation and alarm display with LED - External 15-50 VDC input (parameterization) - Alarm relay - Integrated PI controller - Configurable inputs/outputs (I/O) - MODBUS V6.0 - Motor current limitation - RFID - ISO 15693 compatible - RS-485 MODBUS-RTU - Soft start - Voltage output 3.3-24 VDC, Pmax = 800 mW - Control interface with SELV potential safely disconnected from the mains - Thermal overload protection for electronics/motor - Line undervoltage / phase failure detection |
| EMC immunity to interference | According to EN 61000-6-2 (industrial environment) |
| EMC interference emission | According to EN 61000-6-3 (household environment), except EN 61000-3-2 for professionally used equipment with a total rated power greater than 1 kW |
| Touch current according to IEC 60990 (measuring circuit Fig. 4, TN system) | <= 3.5 mA |
| Electrical hookup | Terminal box |
| Motor protection | Reverse polarity and locked-rotor protection |
| Protection class | I (with customer connection of protective earth) |
| Conformity with standards | EN 61800-5-1; CE |
| Approval | CSA C22.2 No. 77 + CAN/CSA-E60730-1; EAC; UL 1004-7 + 60730-1 |

Product drawing

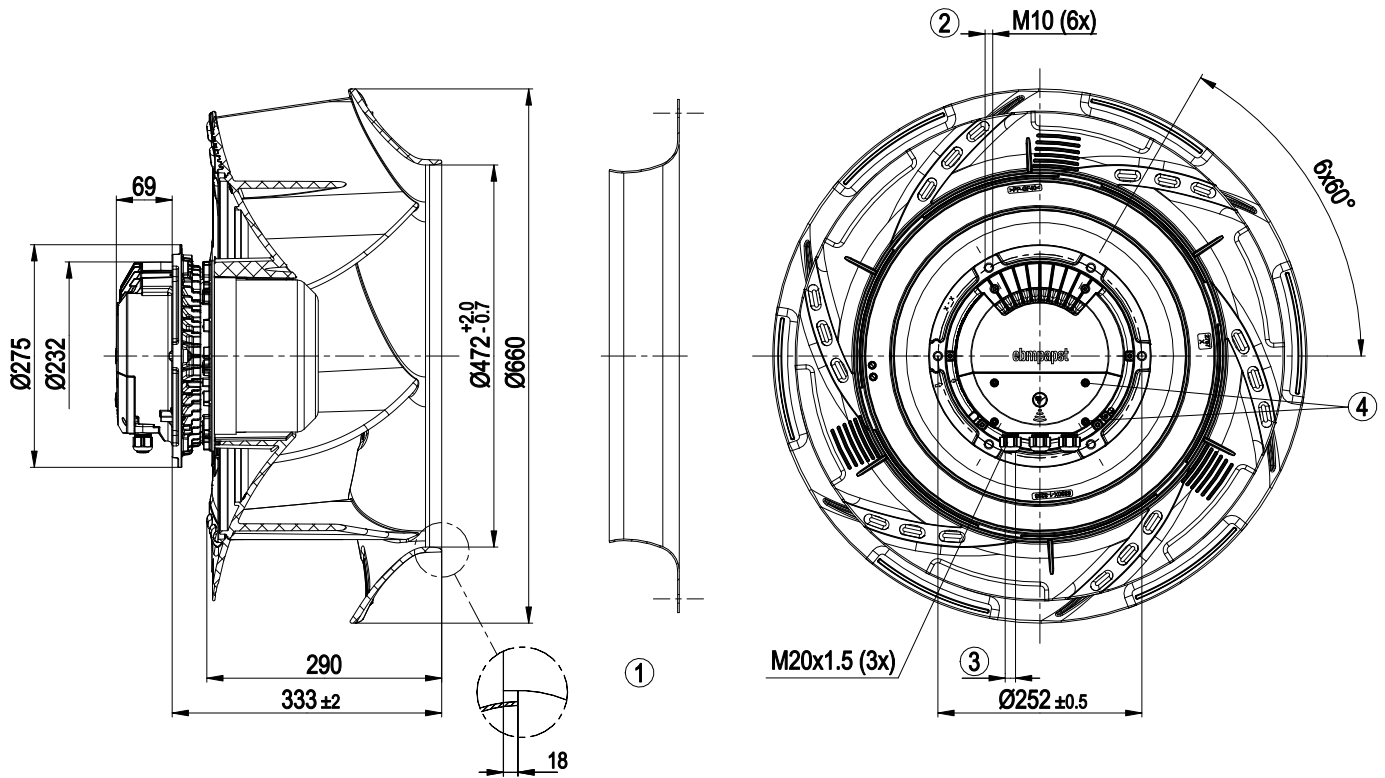

| | |
|---|---|
| 1 | Accessory part: inlet ring 63300-2-4013 not included in scope of delivery |
| 2 | Max. clearance for screw 20 mm |
| 3 | Cable diameter min. 4 mm, max. 10 mm, tightening torque 2 ± 0.3 Nm |
| 4 | Tightening torque 1.5 ± 0.2 Nm |

Accessory part

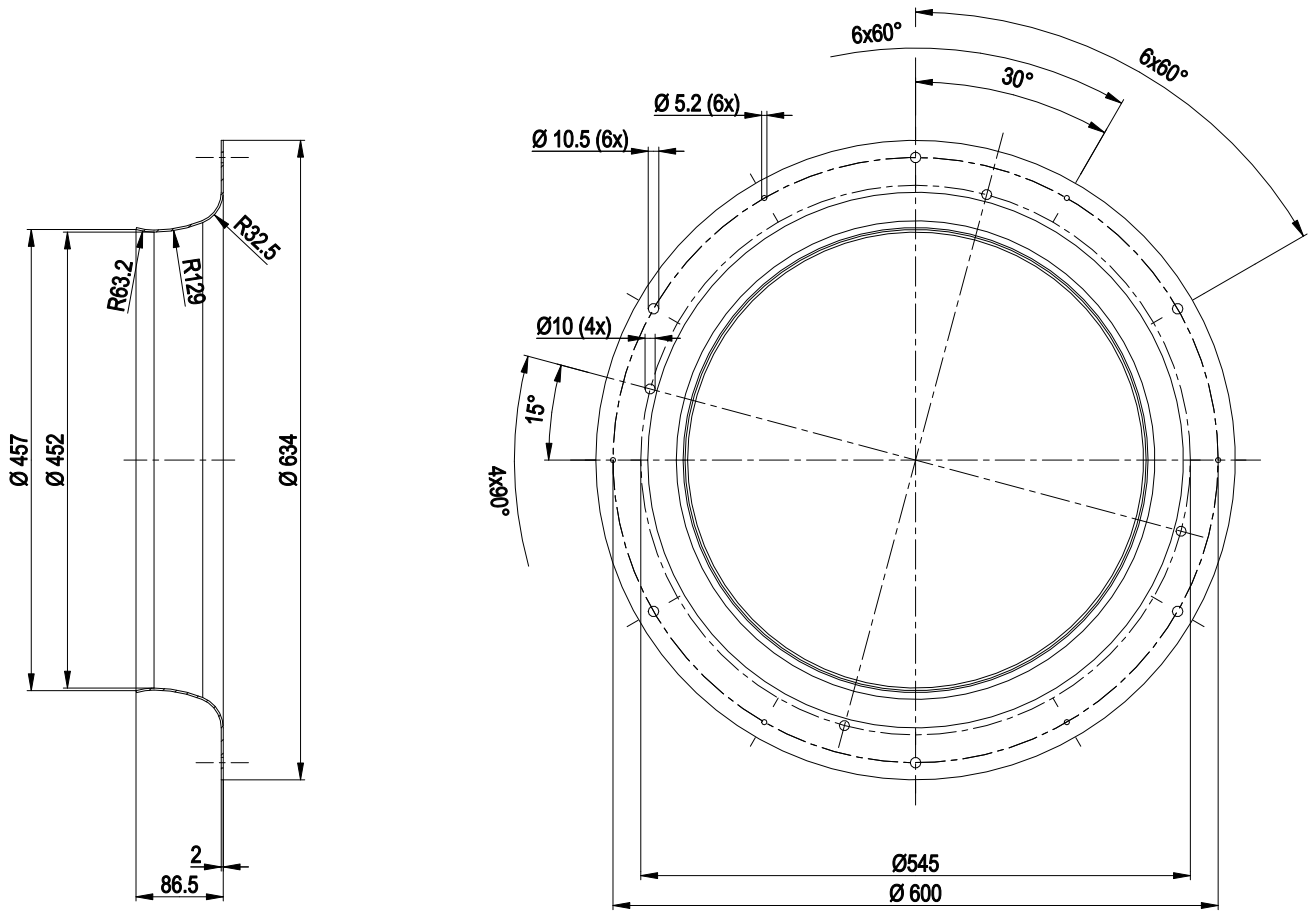

Accessory part: inlet ring 63300-2-4013 not included in scope of delivery

EC centrifugal fan - RadiCal

backward-curved, single-intake

Connection diagram

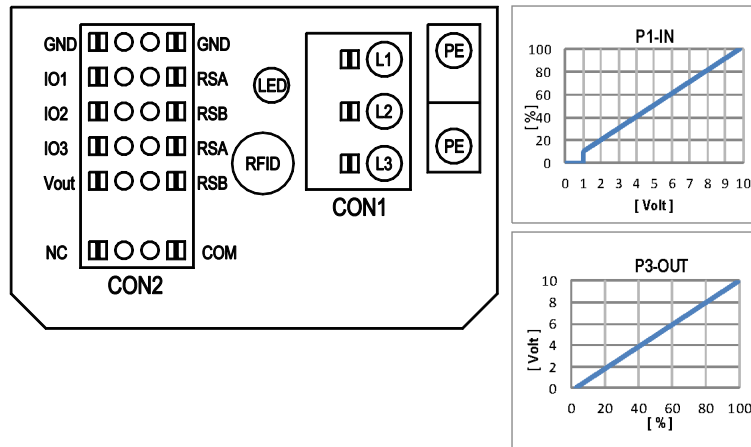

| No. | Conn. | Designation | Function/assignment |
|-----|-------|-------------|---|
| | CON1 | L1, L2, L3 | Power supply, phase, see nameplate for voltage range |
| | PE | PE | Protective earth |
| | CON2 | RSA | RS485 interface for MODBUS, RSA; SELV |
| | CON2 | RSB | RS485 interface for MODBUS, RSB; SELV |
| | CON2 | GND | Reference ground for control interface, SELV |
| | CON2 | IO1 | Function parameterizable (see "Optional interface functions" table) Factory setting: Digital input - high active, function: Disable input, SELV - inactive: Pin open or applied voltage < 1.5 VDC - active: applied voltage 3.5-50 VDC Reset function: Triggering of error reset on change of state from "enabled" to "disabled" |
| | CON2 | IO2 | Function parameterizable (see "Optional interface functions" table) Factory setting: Analog input 0-10 V / PWM, Ri=100 kΩ, function: Set value Characteristic curve parameterizable (see input characteristic curve P1-IN), SELV |
| | CON2 | IO3 | Function parameterizable (see "Optional interface functions" table) Factory setting: Analog output 0-10 V, max. 5 mA, function: Fan modulation level Characteristic curve parameterizable (see output characteristic curve P3-OUT), SELV |
| | CON2 | Vout | Voltage output 3.3-24 VDC ±5%, Pmax=800 mW, voltage parameterizable Factory setting: 10 VDC short-circuit-proof, supply for external devices, SELV alternatively: 15-50 VDC input for parameterization via MODBUS without line voltage |
| | CON2 | COM | Status relay, floating status contact, common connection, contact rating 250 VAC / 2 A (AC1) / min. 10 mA, reinforced insulation on supply side and on control interface side |
| | CON2 | NC | Status relay, floating status contact, break for failure |
| | | LED | green: status = good, ready for operation orange: status = warning red: status = failure |
| | | P1-IN | Input characteristic curve |
| | | P3-OUT | Output characteristic curve |



Curves: Air performance 50 Hz

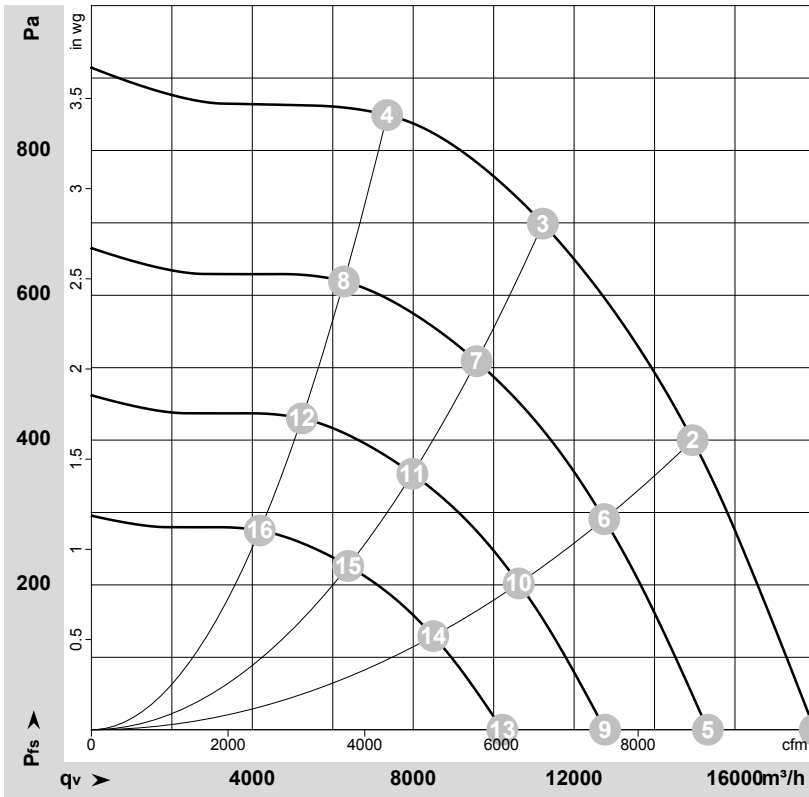

$\rho = 1.15 \text{ kg/m}^3 \pm 2 \%$

Measurement: LU-181577-1

Air performance measured according to ISO 5801 installation category A. For detailed information on the measurement setup, contact ebmpapst. Intake sound level: Sound power level according to ISO 13347 / sound pressure level measured at 1 m distance from fan axis. The values given are valid under the specified measuring conditions and may vary due to conditions of installation. For deviations from the standard configuration, the parameters have to be checked on the installed unit.

Measured values

| | U | f | n | P _{ed} | I | LpA _{in} | LwA _{in} | LwA _{out} | q _v | P _{fs} | q _v | P _{fs} |
|----|-----|----|-------------------|-----------------|------|-------------------|-------------------|--------------------|-------------------|-----------------|----------------|-----------------|
| | V | Hz | min ⁻¹ | W | A | dB(A) | dB(A) | dB(A) | m ³ /h | Pa | cfm | in. wg |
| 1 | 400 | 50 | 1400 | 2317 | 3.60 | 82 | 90 | 94 | 17980 | 0 | 10585 | 0.00 |
| 2 | 400 | 50 | 1400 | 3245 | 4.98 | 76 | 83 | 88 | 14950 | 400 | 8800 | 1.61 |
| 3 | 400 | 50 | 1400 | 3600 | 5.50 | 73 | 80 | 86 | 11225 | 700 | 6605 | 2.81 |
| 4 | 400 | 50 | 1400 | 3265 | 5.02 | 77 | 84 | 88 | 7350 | 850 | 4325 | 3.41 |
| 5 | 400 | 50 | 1200 | 1435 | 2.23 | 78 | 86 | 90 | 15325 | 0 | 9020 | 0.00 |
| 6 | 400 | 50 | 1200 | 2010 | 3.09 | 72 | 79 | 84 | 12750 | 294 | 7505 | 1.18 |
| 7 | 400 | 50 | 1200 | 2219 | 3.40 | 69 | 76 | 82 | 9575 | 511 | 5635 | 2.05 |
| 8 | 400 | 50 | 1200 | 2033 | 3.12 | 73 | 80 | 84 | 6280 | 619 | 3695 | 2.49 |
| 9 | 400 | 50 | 1000 | 830 | 1.29 | 74 | 81 | 85 | 12770 | 0 | 7515 | 0.00 |
| 10 | 400 | 50 | 1000 | 1163 | 1.79 | 67 | 74 | 79 | 10625 | 204 | 6255 | 0.82 |
| 11 | 400 | 50 | 1000 | 1284 | 1.97 | 64 | 71 | 77 | 7980 | 355 | 4695 | 1.43 |
| 12 | 400 | 50 | 1000 | 1177 | 1.81 | 68 | 76 | 80 | 5230 | 430 | 3080 | 1.73 |
| 13 | 400 | 50 | 800 | 425 | 0.66 | 68 | 75 | 80 | 10215 | 0 | 6015 | 0.00 |
| 14 | 400 | 50 | 800 | 595 | 0.91 | 61 | 68 | 74 | 8500 | 131 | 5005 | 0.53 |
| 15 | 400 | 50 | 800 | 658 | 1.01 | 59 | 66 | 71 | 6385 | 227 | 3755 | 0.91 |
| 16 | 400 | 50 | 800 | 602 | 0.93 | 63 | 70 | 74 | 4185 | 275 | 2465 | 1.10 |

U = Voltage · f = Frequency · n = Speed (rpm) · P_{ed} = Power consumption · I = Current draw · LpA_{in} = Sound pressure level intake side · LwA_{in} = Sound power level intake side
 LwA_{out} = Sound power level outlet side · q_v = Air flow · P_{fs} = Pressure increase

