

R3G560-AQ04-01

# EC centrifugal fan - Plug fan

backward curved, single inlet



**ASIA PACIFIC SHENGRUI LIMITED**

Phone +00852 56261528

info@apacfan.com

www.apacfan.com



## Nominal data

Type	R3G560-AQ04-01	
Motor	M3G150-NA	
Phase		3~
Nominal voltage	VAC	400
Nominal voltage range	VAC	380 .. 480
Frequency	Hz	50/60
Type of data definition		ml
Speed	min <sup>-1</sup>	1750
Power input	W	4700
Current draw	A	7.3
Min. ambient temperature	°C	-25
Max. ambient temperature	°C	40

ml = max. load · me = max. efficiency · fa = running at free air · cs = customer specs · cu = customer unit  
Subject to alterations

## Data according to ErP directive

Installation category	A
Efficiency category	Static
Variable speed drive integrated	Integrated
Specific ratio*	1,01

\* Specific ratio =  $1 + p_{fs} / 100\,000\text{ Pa}$

		Actual	Request 2013	Request 2015
Overall efficiency $\eta_{es}$		67,2	54,5	58,5
Efficiency grade N		70,7	58	62
Power input $P_{ed}$	kW	4,67		
Air flow $q_v$	m <sup>3</sup> /h	11640		
Pressure increase $p_{fs}$	Pa	934		
Speed n	min <sup>-1</sup>	1765		

Data established at point of optimum efficiency



## Technical features

<b>Mass</b>	40 kg
<b>Size</b>	560 mm
<b>Surface of rotor</b>	Coated in black
<b>Material of electronics housing</b>	Die-cast aluminium
<b>Material of impeller</b>	Aluminium sheet
<b>Number of blades</b>	7
<b>Direction of rotation</b>	Clockwise, seen on rotor
<b>Type of protection</b>	IP 54
<b>Insulation class</b>	"F"
<b>Humidity class</b>	F4-1
<b>Max. permissible ambient motor temp. (transp./ storage)</b>	+80 °C
<b>Min. permissible ambient motor temp. (transp./storage)</b>	-40 °C
<b>Mounting position</b>	Shaft horizontal or rotor on bottom; rotor on top on request
<b>Condensate discharge holes</b>	Rotor-side
<b>Operation mode</b>	S1
<b>Motor bearing</b>	Ball bearing
<b>Technical features</b>	<ul style="list-style-type: none"> <li>- Output 20 VDC, max. 50 mA</li> <li>- Output for slave 0-10 V</li> <li>- Input for sensor 0-10 V or 4-20 mA</li> <li>- External 24 V input (programming)</li> <li>- Alarm relay</li> <li>- Integrated PID controller</li> <li>- Motor current limit</li> <li>- PFC, passive</li> <li>- RS485 MODBUS RTU</li> <li>- Soft start</li> <li>- Control input 0-10 VDC / PWM</li> <li>- Over-temperature protected electronics / motor</li> <li>- Line undervoltage / phase failure detection</li> </ul>
<b>EMC interference immunity</b>	Acc. to EN 61000-6-2 (industrial environment)
<b>EMC interference emission</b>	Acc. to EN 61000-6-3 (household environment)
<b>Leakage current</b>	<= 3.5 mA
<b>Electrical leads</b>	Via terminal box
<b>Motor protection</b>	Reverse polarity and locked-rotor protection
<b>Protection class</b>	I (if protective earth is connected by customer)
<b>Product conforming to standard</b>	EN 61800-5-1; CE
<b>Approval</b>	C22.2 Nr.77 + CAN/CSA-E60730-1; UL 1004-7 + 60730

# EC centrifugal fan - Plug fan

backward curved, single inlet

## Product drawing

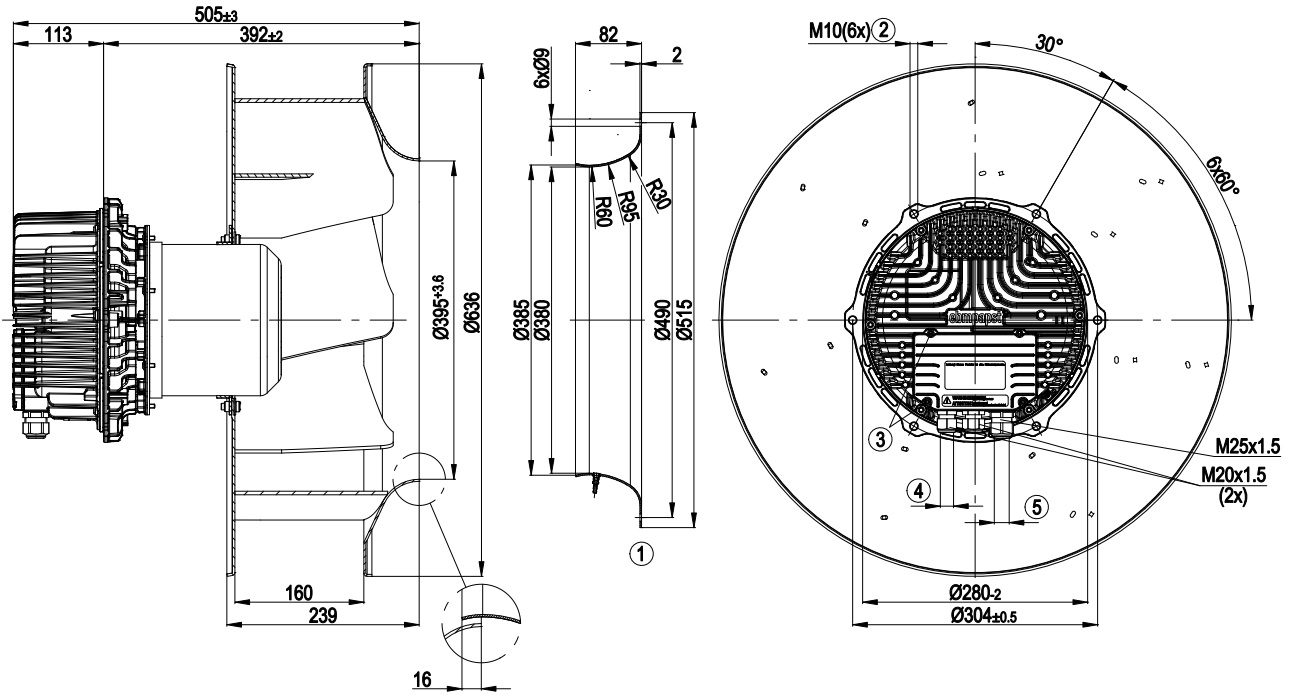

1	Accessory part: Inlet nozzle 64030-2-4013 with a bleeder connection for pressure relief not included in the standard scope of delivery
2	Depth of screw max. 20 mm
3	Tightening torque 3.5±0.5 Nm
4	Cable diameter: min. 4 mm, max. 10 mm; tightening torque: 4±06 Nm
5	Cable diameter: min. 9 mm, max. 16 mm; tightening torque: 6±0. Nm



## Connection screen

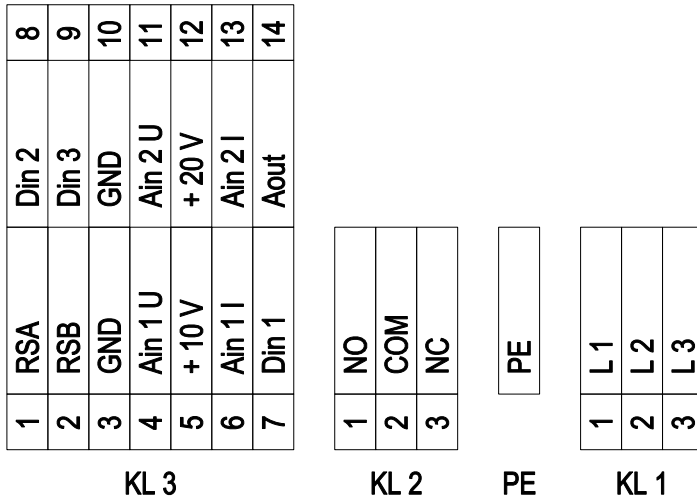

No.	Pin	Signal	Function / assignment
KL 1	1	L1	Mains supply connection, supply voltage 3~380-480 VAC; 50/60 Hz
KL 1	2	L2	Mains supply connection, supply voltage 3~380-480 VAC; 50/60 Hz
KL 1	3	L3	Mains supply connection, supply voltage 3~380-480 VAC; 50/60 Hz
PE		PE	Earth connection, PE connection
KL 2	1	NO	Status relay, floating status contact; normally open; close with error
KL2	2	COM	Status relay; floating status contact; changeover contact; common connection; contact rating 250 VAC / 2 A (AC1)
KL2	3	NC	Status relay, floating status contact; break with error
KL 3	1	RSA	Bus connection RS485; RSA; MODBUS RTU
KL 3	2	RSB	Bus connection RS485; RSB; MODBUS RTU
KL 3	3 / 10	GND	Signal ground for control interface KL3
KL 3	4	Ain1 U	Analogue input 1 (set value); 0-10 V; Ri= 100 kΩ; parametrisable curves; only usable as alternative to input Ain1 I
KL 3	5	+ 10 V	Fixed voltage output 10 VDC; + 10 V +/-3%; max. 10 mA; short circuit proof; power supply for ext. devices (e.g. potentiometer)
KL 3	6	Ain1 I	Analogue input 1 (set value); 4-20 mA; Ri= 100 Ω; parametrisable curves; only usable as alternative to input Ain1 U
KL 3	7	Din1	Digital input 1: enabling of electronics; enabling: open pin or applied voltage 5 to 50 VDC; disabling: bridge to GND or applied voltage < 1 VDC; reset function: triggers software reset after a level change to <1 V
KL 3	8	Din2	Digital input 2: parameter set switch 1/2; according to EEPROM setting, the valid/used parameter set is selectable per BUS or per digital input DIN2. Parameter set 1: open pin or applied voltage 5 to 50 VDC; parameter set 2: bridge to GND or applied voltage < 1 VDC
KL 3	9	Din3	Digital input 3: Control characteristic of the integrated controller; according to EEPROM setting, the control characteristic of the integrated controller is normally/inversely selectable per BUS or per digital input; normal: open pin or applied voltage 5 to 50 VDC (control deviation = actual sensor value - set value) inverse: bridge to GND or applied voltage < 1 VDC (control deviation = set value - actual sensor value)
KL 3	11	Ain2 U	Analogue input 2; actual sensor value 0-10 V; Ri= 100 kΩ; parametrisable curve; only usable as alternative to input Ain2 I
KL 3	12	+ 20 V	Fixed voltage output 20 VDC; + 20 V +/-25/-10 %; max. 50 mA; short circuit proof; power supply for ext. devices (e.g. sensors)
KL 3	13	Ain2 I	Analogue input 2; actual sensor value 4-20 mA; Ri= 100 Ω; parametrisable curve; only usable as alternative to input Ain2 U
KL 3	14	Aout	Analogue output 0-10 V; max. 5 mA; output of the actual motor control factor (output voltage of electronics)/ of the actual motor speed; function selectable per bus; parametrisable curve.

## Charts: Air flow 50 Hz

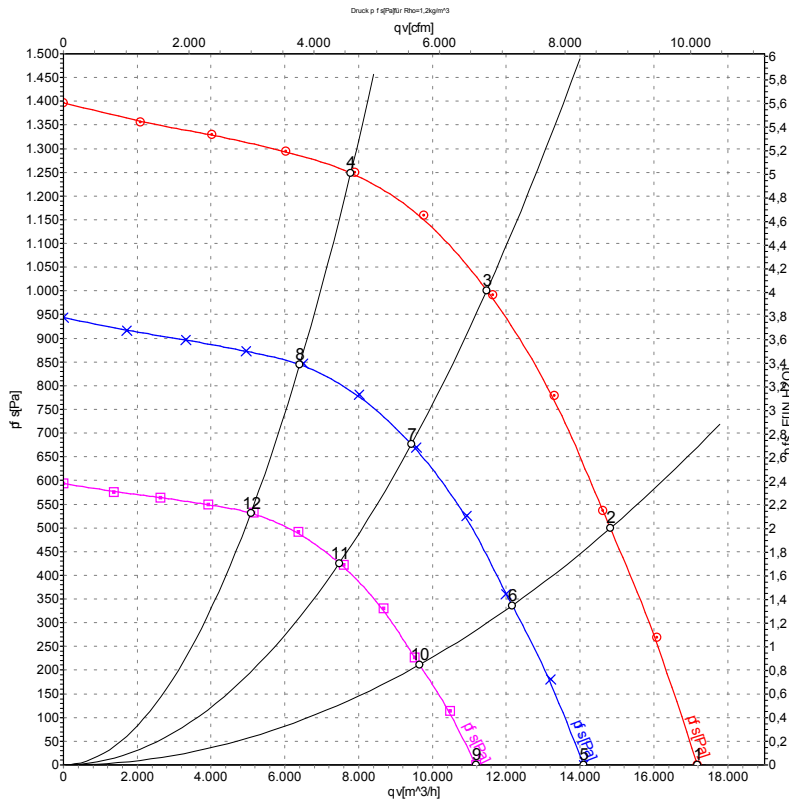

Measurement: LU-128639

Air performance measured as per ISO 5801 Installation category A. For detailed information on the measuring set-up, please contact ebmpapst. Suction-side noise levels: LwA measured as per ISO 13347 / LpA measured with 1m distance to fan axis. The values given are valid under the measuring conditions mentioned above and may vary according to the actual installation situation. With any deviation from the standard set-up, the specific values have to be checked and reviewed with the unit installed.

## Measured values

	U	f	n	P <sub>ed</sub>	I	LpA <sub>in</sub>	LwA <sub>in</sub>	LwA <sub>out</sub>	qv	p <sub>fs</sub>
	V	Hz	min <sup>-1</sup>	W	A	dB(A)	dB(A)	dB(A)	m <sup>3</sup> /h	Pa
1	400	50	1750	3032	4.77	88	97	103	17170	0
2	400	50	1750	3929	6.10	84	91	96	14820	500
3	400	50	1750	4700	7.30	78	84	91	11470	1000
4	400	50	1750	4366	6.71	79	86	92	7785	1250
5	400	50	1450	1675	2.64	84	93	98	14090	0
6	400	50	1450	2171	3.37	80	87	92	12160	336
7	400	50	1450	2602	4.01	74	80	86	9430	681
8	400	50	1450	2432	3.74	75	82	88	6405	848
9	400	50	1150	836	1.32	79	88	93	11180	0
10	400	50	1150	1083	1.68	75	82	87	9650	211
11	400	50	1150	1298	2.00	68	75	81	7480	428
12	400	50	1150	1213	1.87	70	76	83	5080	534

