

R3G250-RR01-H1

EC centrifugal fan - RadiCal

backward curved, single inlet



ASIA PACIFIC SHENGRUI LIMITED

Phone +00852 56261528

info@apacfan.com

www.apacfan.com



Nominal data

Type	R3G250-RR01-H1	
Motor	M3G084-DF	
Phase		1~
Nominal voltage	VAC	230
Nominal voltage range	VAC	200 .. 277
Frequency	Hz	50/60
Type of data definition		ml
Speed	min ⁻¹	3740
Power input	W	500
Current draw	A	2.2
Min. ambient temperature	°C	-25
Max. ambient temperature	°C	60

ml = Max. load · me = Max. efficiency · fa = Running at free air · cs = Customer specs · cu = Customer unit
Subject to alterations

Data according to ErP directive

Installation category	A
Efficiency category	Static
Variable speed drive	Yes
Specific ratio*	1.01

* Specific ratio = $1 + p_{fs} / 100\,000\text{ Pa}$

		Actual	Request 2015
Overall efficiency η_{es}	%	60.1	48.3
Efficiency grade N		73.8	62
Power input P_{ed}	kW	0.5	
Air flow q_v	m ³ /h	1355	
Pressure increase p_{fs}	Pa	733	
Speed n	min ⁻¹	3735	

Data definition with optimum efficiency. LU-151690
The ErP data is determined using a motor-impeller combination in a standardised measurement configuration.



Technical features

Mass	3.9 kg
Size	250 mm
Surface of rotor	Coated in black
Material of impeller	PA plastic
Housing material	Die-cast aluminium
Number of blades	7
Direction of rotation	Clockwise, seen on rotor
Type of protection	IP 54
Insulation class	"F"
Humidity class	F3-1
Max. permissible ambient motor temp. (transp./ storage)	+80 °C
Min. permissible ambient motor temp. (transp./storage)	-40 °C
Mounting position	Shaft horizontal or rotor on bottom; rotor on top on request
Condensate discharge holes	Rotor-side
Operation mode	S1
Motor bearing	Ball bearing
Technical features	<ul style="list-style-type: none"> - Output 10 VDC, max. 10 mA - Operation and alarm display - Alarm relay - Integrated PID controller - Output limit - Motor current limit - PFC, active - RS485 MODBUS RTU - Soft start - Control input 0-10 VDC / PWM - Control interface with SELV potential safely disconnected from the mains - Over-temperature protected electronics / motor - Line undervoltage / phase failure detection
EMC interference immunity	Acc. to EN 61000-6-2 (industrial environment)
EMC harmonics	Acc. to EN 61000-3-2/3
EMC interference emission	Acc. to EN 61000-6-3 (household environment)
Touch current acc. IEC 60990 (measuring network Fig. 4, TN system)	<= 3.5 mA
Motor protection	Thermal overload protector (TOP) wired internally
Cable exit	Variable
Protection class	I (if protective earth is connected by customer at the connection point of the housing)
Product conforming to standard	EN 61800-5-1; EN 60335-1; CE
Approval	EAC

Product drawing

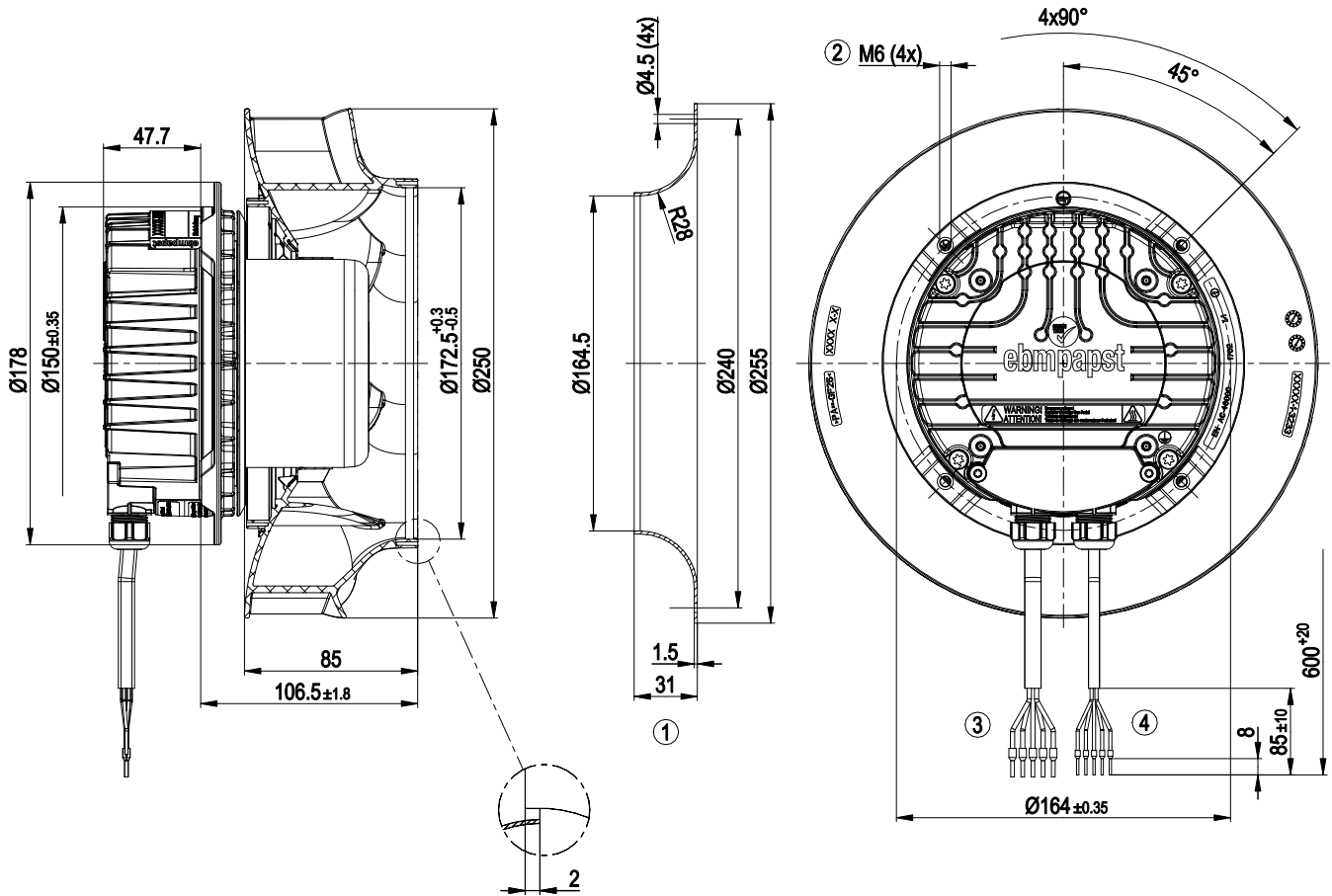

1	Accessory part: inlet nozzle 96359-2-4013 not included in scope of delivery
2	Depth of screw max. 16 mm
3	Connection line PVC AWG18, 5x crimped core-end sleeves
4	Connection line PVC AWG22, 5x crimped core-end sleeves

Connection screen

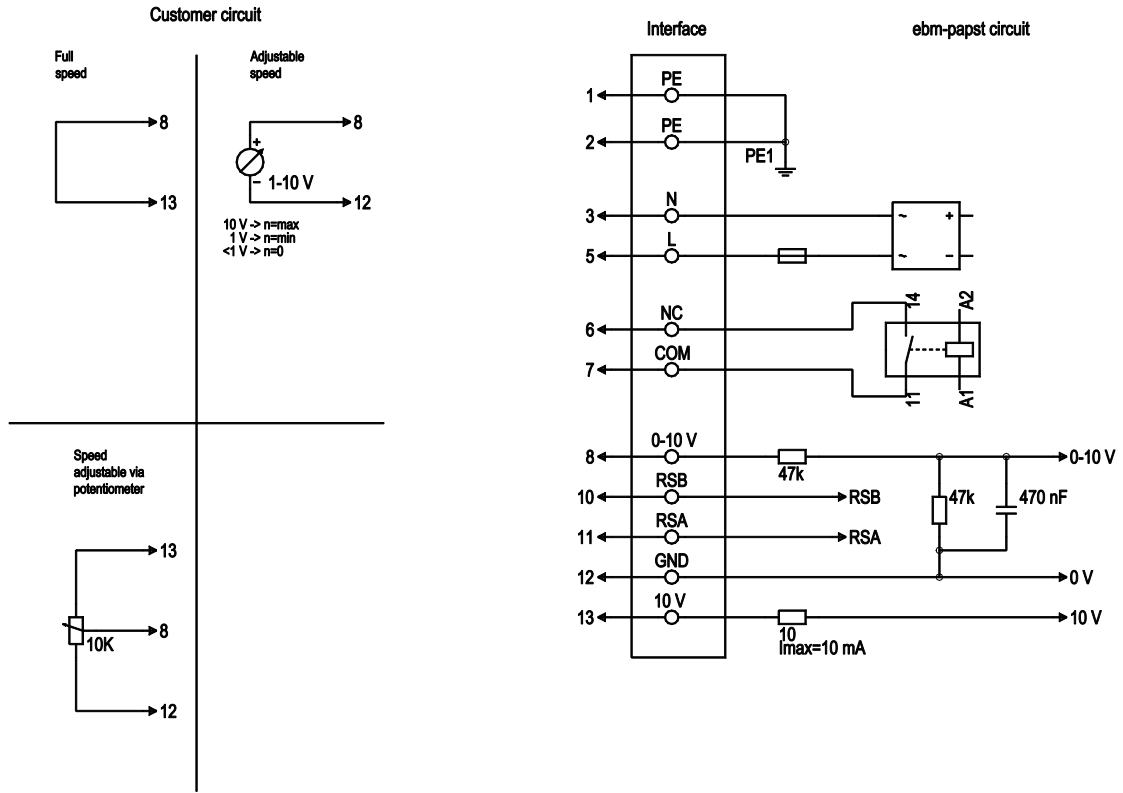

No.	Conn.	Designation	Colour	Function / assignment
1	1, 2	PE	green/yellow	Protective earth
1	3	N	blue	Supply voltage, neutral conductor, 50/60 Hz
1	5	L	black	Supply voltage, phase, 50/60 Hz
1	6	NC	white 1	Status relay, floating status contact; break for failure, contact rating 250 VAC / 2A (AC1) min. 10 mA, basic insulation on mains side and reinforced insulation on control interface side
1	7	COM	white 2	Status relay, floating status contact; common connection, contact rating 250 VAC / 2A (AC1) min. 10 mA, basic insulation on mains side and reinforced insulation on control interface side
2	8	0-10V	yellow	Analogue input 1 (set value); 0-10 V; Ri=100kΩ; parametrisable curve
2	10	RSB	brown	RS485 interface for Modbus, RSB
2	11	RSA	white	RS485 interface for Modbus, RSA
2	12	GND	blue	Reference ground for control interface, SELV
2	13	+10V	red	Fixed voltage output 10 VDC; +10 V +/-3%; max. 10 mA; short-circuit-proof; power supply for external devices (e.g. potentiometer)

Charts: Air flow 50 Hz

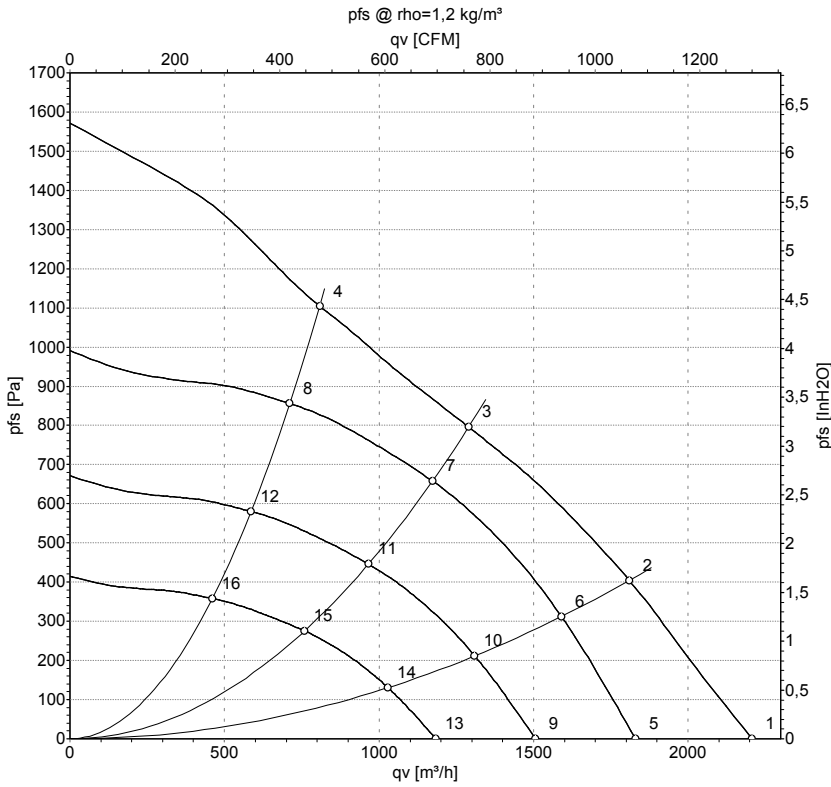

Measurement: LU-151690

Air performance measured as per ISO 5801 Installation category A. For detailed information on the measuring set-up, please contact ebm-papst. Suction-side noise levels: LwA measured as per ISO 13347 / LpA measured with 1m distance to fan axis. The values given are valid under the measuring conditions mentioned above and may vary according to the actual installation situation. With any deviation from the standard set-up, the specific values have to be checked and reviewed with the unit installed.

Measured values

	U	f	n	P _{ed}	I	LpA _{in}	LwA _{in}	qv	p _{fs}
	V	Hz	min ⁻¹	W	A	dB(A)	dB(A)	m ³ /h	Pa
1	230	50	4100	500	2.20	81	89	2210	0
2	230	50	3870	500	2.20	75	83	1810	400
3	230	50	3740	500	2.20	70	78	1290	800
4	230	50	3860	500	2.20	77	84	810	1100
5	230	50	3400	292	1.27	76	84	1830	0
6	230	50	3400	346	1.51	72	80	1590	313
7	230	50	3400	383	1.67	68	75	1175	658
8	230	50	3400	348	1.52	74	81	710	856
9	230	50	2800	163	0.71	71	79	1505	0
10	230	50	2800	193	0.84	67	75	1310	212
11	230	50	2800	214	0.93	63	71	965	446
12	230	50	2800	194	0.85	69	76	585	580
13	230	50	2200	79	0.35	65	73	1185	0
14	230	50	2200	94	0.41	61	69	1030	131
15	230	50	2200	104	0.45	57	65	760	276
16	230	50	2200	94	0.41	63	70	460	358

U = Supply voltage · f = Frequency · n = Speed · P_{ed} = Power input · I = Current draw · LpA_{in} = Sound pressure level inlet side · LwA_{in} = Sound power level inlet side · qv = Air flow
p_s = Pressure increase

