

ASIA PACIFIC SHENGRUI LIMITED

Phone +00852 56261528

info@apacfan.com

www.apacfan.com

Limited partnership · Headquarters Mulfingen  
County court Stuttgart · HRA 590344

General partner Elektrobau Mulfingen GmbH · Headquarters Mulfingen  
County court Stuttgart · HRB 590142



## Nominal data

Type	R3G250-RE07-07	
Motor	M3G055-DF	
Phase		1~
Nominal voltage	VAC	230
Nominal voltage range	VAC	200 .. 240
Frequency	Hz	50/60
Type of data definition		ml
Speed	min <sup>-1</sup>	2510
Power input	W	170
Current draw	A	1.4
Min. ambient temperature	°C	-25
Max. ambient temperature	°C	60

ml = Max. load · me = Max. efficiency · fa = Running at free air · cs = Customer specs · cu = Customer unit  
Subject to alterations

## Data according to ErP directive

Installation category	A
Efficiency category	Static
Variable speed drive	Yes
Specific ratio*	1.00

\* Specific ratio =  $1 + p_{fs} / 100\,000 \text{ Pa}$

		Actual	Request 2013	Request 2015
Overall efficiency $\eta_{es}$	%	57.8	39.1	43.1
Efficiency grade N		76.7	58	62
Power input $P_{ed}$	kW	0.16		
Air flow $q_v$	m <sup>3</sup> /h	800		
Pressure increase $p_{fs}$	Pa	380		
Speed n	min <sup>-1</sup>	2535		

Data definition with optimum efficiency. LU-153273  
The ErP data is determined using a motor-impeller combination in a standardised measurement configuration.



## Technical features

<b>Mass</b>	1.9 kg
<b>Size</b>	250 mm
<b>Surface of rotor</b>	Thick layer passivated
<b>Material of electronics housing</b>	Die-cast aluminium
<b>Material of impeller</b>	PA plastic
<b>Number of blades</b>	7
<b>Direction of rotation</b>	Clockwise, seen on rotor
<b>Type of protection</b>	IP 54
<b>Insulation class</b>	"B"
<b>Max. permissible ambient motor temp. (transp./ storage)</b>	+ 80 °C
<b>Min. permissible ambient motor temp. (transp./storage)</b>	- 40 °C
<b>Mounting position</b>	Any
<b>Condensate discharge holes</b>	None, open rotor
<b>Operation mode</b>	S1
<b>Motor bearing</b>	Ball bearing
<b>Technical features</b>	<ul style="list-style-type: none"> <li>- Output 10 VDC, max. 1.1 mA</li> <li>- Tach output</li> <li>- Motor current limit</li> <li>- Soft start</li> <li>- Control input 0-10 VDC / PWM</li> <li>- Over-temperature protected electronics / motor</li> <li>- Line undervoltage detection</li> </ul>
<b>EMC interference immunity</b>	Acc. to EN 61000-6-2 (industrial environment)
<b>EMC interference emission</b>	Acc. to EN 61000-6-4 (industrial environment)
<b>Touch current acc. IEC 60990 (measuring network Fig. 4, TN system)</b>	<= 3.5 mA
<b>Motor protection</b>	Locked-rotor protection
<b>Cable exit</b>	Variable
<b>Protection class</b>	I (if protective earth is connected by customer)
<b>Product conforming to standard</b>	EN 60335-1; CE
<b>Approval</b>	CCC; CSA C22.2 Nr.77; UL 2111

Product drawing

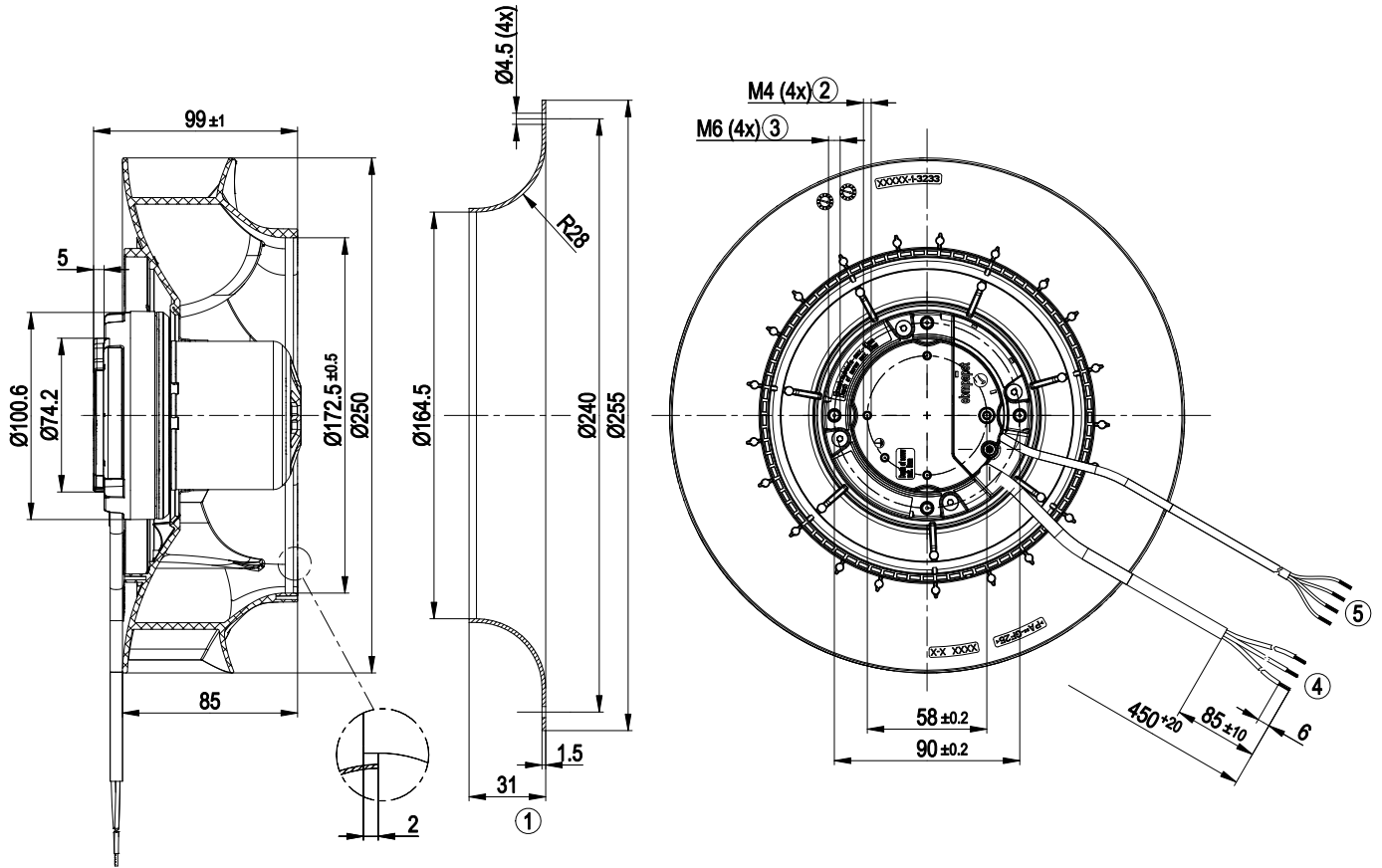

1	Accessory part: inlet nozzle 96359-2-4013, not included in scope of delivery
2	Depth of screw max. 5 mm
3	Depth of screw max. 10 mm
4	Connection line PVC 3X AWG20, 3x lead tips crimped
5	Connection line PVC AWG22, 4x lead tips crimped

## Connection screen

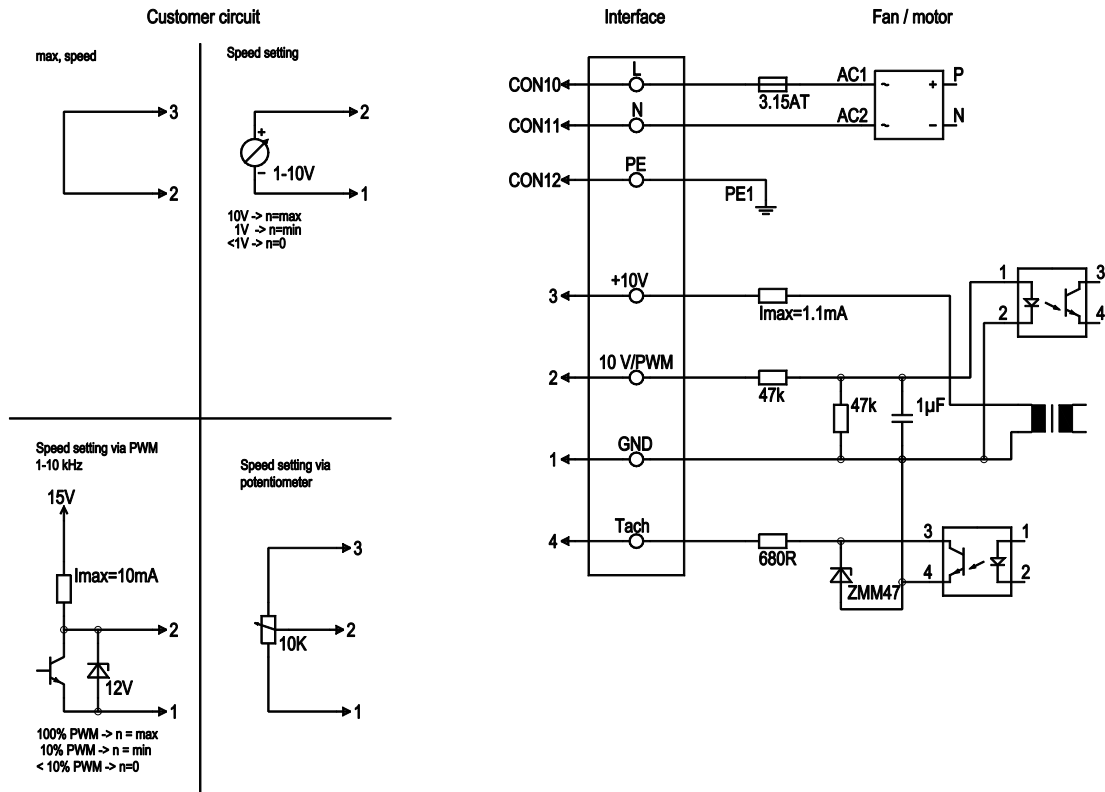

No.	Conn.	Designation	Colour	Function / assignment
	CON10	L	black	Power supply 230 VAC, 50-60 Hz, for voltage range refer to rating plate
	CON11	N	blue	Neutral conductor
	CON12	PE	green/yellow	Protective earth
	1	GND	blue	GND - Connection for control interface
	2	0- 10V PWM	yellow	Control input 0 - 10 V or PWM, electrically isolated
	3	10V/ max 1.1mA	red	Voltage output 10V/ 1.1mA, electrically isolated, not short-circuit-proof.
	4	Tach	white	Tach output: open collector, 1 pulse per revolution, electrically isolated

## Charts: Air flow 50 Hz

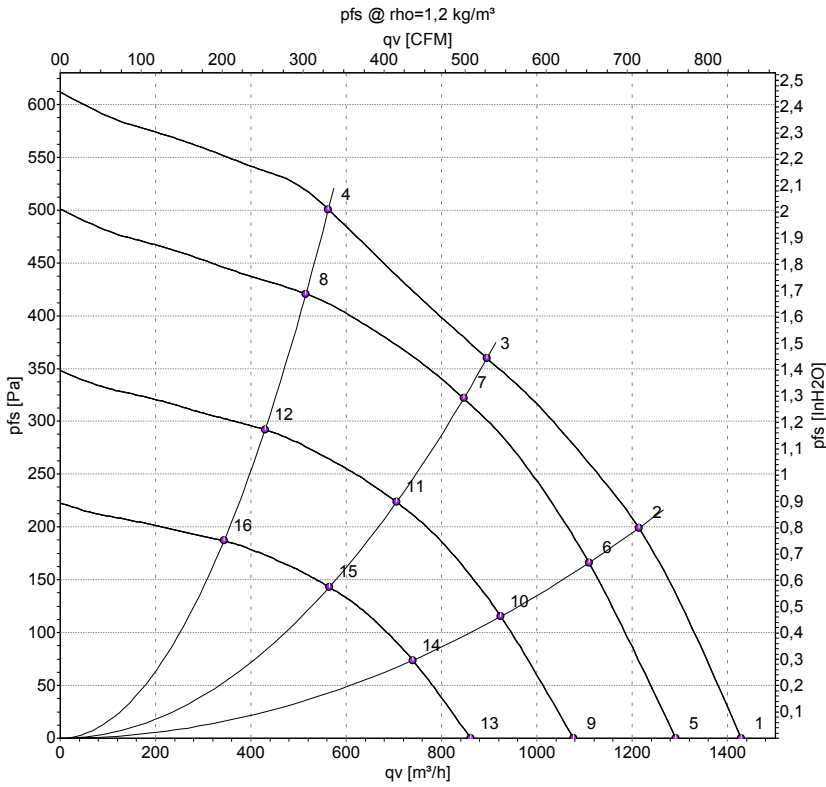

Measurement: LU-154717

Air performance measured as per ISO 5801 Installation category A. For detailed information on the measuring set-up, please contact ebm-papst. Suction-side noise levels: LwA measured as per ISO 13347 / LpA measured with 1m distance to fan axis. The values given are valid under the measuring conditions mentioned above and may vary according to the actual installation situation. With any deviation from the standard set-up, the specific values have to be checked and reviewed with the unit installed.

## Measured values

	U	f	n	P <sub>ed</sub>	I	LpA <sub>in</sub>	LwA <sub>in</sub>	qv	p <sub>fs</sub>
	V	Hz	min <sup>-1</sup>	W	A	dB(A)	dB(A)	m <sup>3</sup> /h	Pa
1	230	50	2655	143	1.18	68	76	1430	0
2	230	50	2630	170	1.40	64	72	1215	200
3	230	50	2510	170	1.40	60	67	895	360
4	230	50	2620	168	1.39	65	73	560	500
5	230	50	2400	105	0.87	66	73	1290	0
6	230	50	2400	129	1.07	62	69	1110	168
7	230	50	2400	144	1.19	59	66	845	322
8	230	50	2400	129	1.07	63	70	515	421
9	230	50	2000	61	0.51	61	69	1075	0
10	230	50	2000	75	0.62	57	65	925	116
11	230	50	2000	83	0.69	54	62	705	224
12	230	50	2000	75	0.62	59	66	430	292
13	230	50	1600	31	0.26	55	63	860	0
14	230	50	1600	38	0.32	52	59	740	75
15	230	50	1600	43	0.35	48	56	565	143
16	230	50	1600	38	0.32	53	60	345	187

U = Supply voltage · f = Frequency · n = Speed · P<sub>ed</sub> = Power input · I = Current draw · LpA<sub>in</sub> = Sound pressure level inlet side · LwA<sub>in</sub> = Sound power level inlet side · qv = Air flow  
 p<sub>fs</sub> = Pressure increase

