

R2E280-AE52-05

AC centrifugal fan

backward curved, single inlet



ASIA PACIFIC SHENGRUI LIMITED

Phone +00852 56261528

info@apacfan.com

www.apacfan.com

Nominal data

Type	R2E280-AE52-05	
Motor	M2E068-EC	
Phase		1~
Nominal voltage	VAC	230
Frequency	Hz	50
Type of data definition		fa
Valid for approval / standard		-
Speed	min ⁻¹	2700
Power input	W	225
Current draw	A	1.0
Motor capacitor	μF	7
Capacitor voltage	VDB	400
Capacitor standard		P0 (CE)
Min. back pressure	Pa	0
Min. ambient temperature	°C	-25
Max. ambient temperature	°C	40
Starting current	A	2.5

ml = Max. load · me = Max. efficiency · fa = Running at free air · cs = Customer specs · cu = Customer unit
Subject to alterations



Technical features

Mass	3.5 kg
Size	280 mm
Surface of rotor	Coated in black
Material of electronics housing	Rotor: Coated in black
Material of impeller	Sheet steel, coated in black
Number of blades	11
Direction of rotation	Clockwise, seen on rotor
Type of protection	IP 44; Depending on installation and position as per EN 60034-5
Insulation class	"F"
Humidity class	F1-2
Max. permissible ambient motor temp. (transp./ storage)	+ 80 °C
Min. permissible ambient motor temp. (transp./storage)	- 40 °C
Mounting position	Shaft horizontal or rotor on bottom; rotor on top on request
Condensate discharge holes	Rotor-side
Operation mode	S1
Motor bearing	Ball bearing
Touch current acc. IEC 60990 (measuring network Fig. 4, TN system)	< 0.75 mA
Motor protection	Thermal overload protector (TOP) wired internally
Cable exit	Variable
Protection class	I (if protective earth is connected by customer)
Approval	CCC; EAC

AC centrifugal fan

backward curved, single inlet

Product drawing

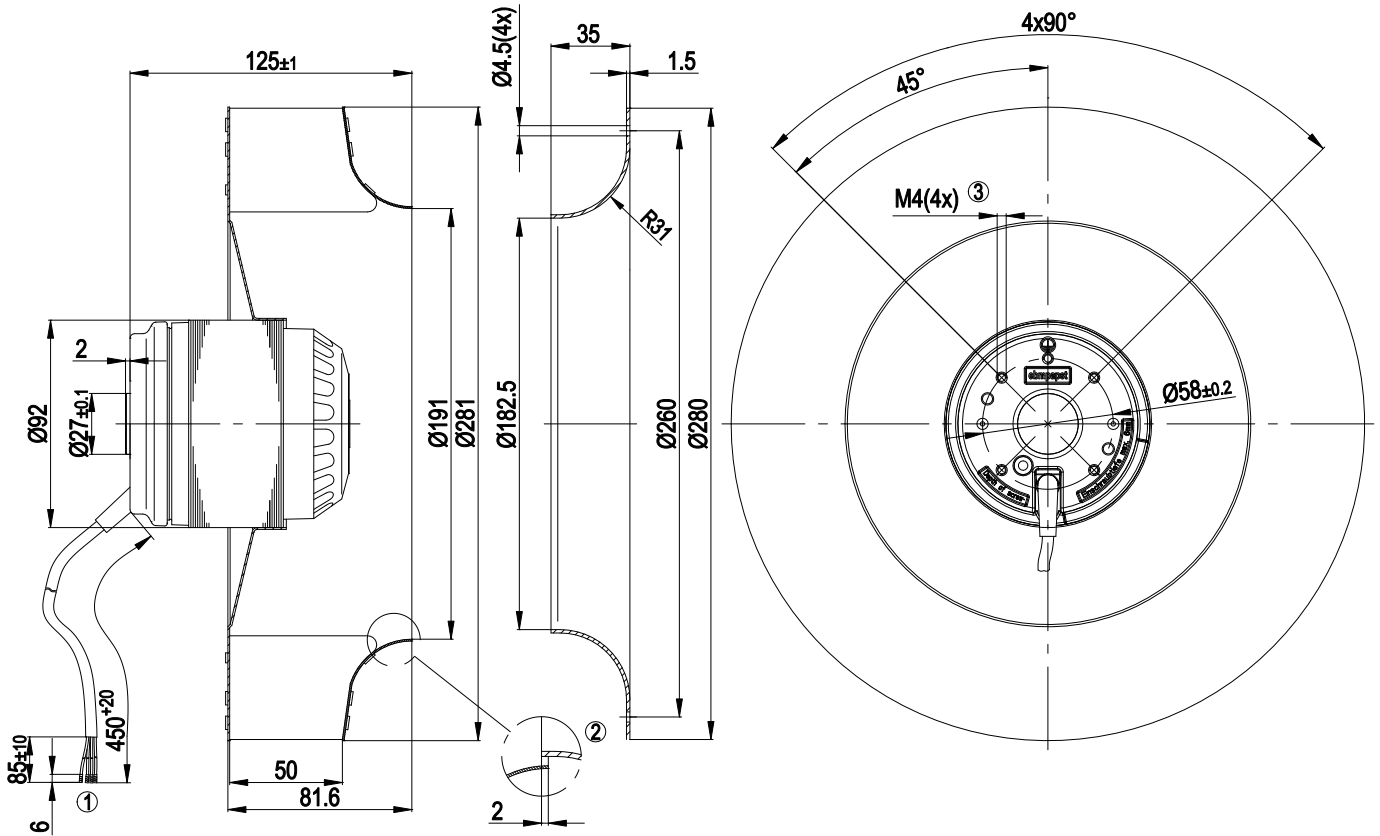

- 1 Connection line silicone 4G 0.5 mm², 4 x brass lead tips crimped
- 2 Accessory part: Inlet nozzle 96360-2-4013, not included in the standard scope of delivery
- 3 Depth of screw max. 6 mm

Connection screen

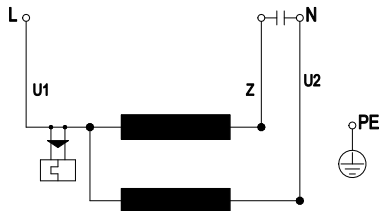

U1	blue	Z	brown	U2	black
PE	green/yellow				



Charts: Air flow 50 Hz

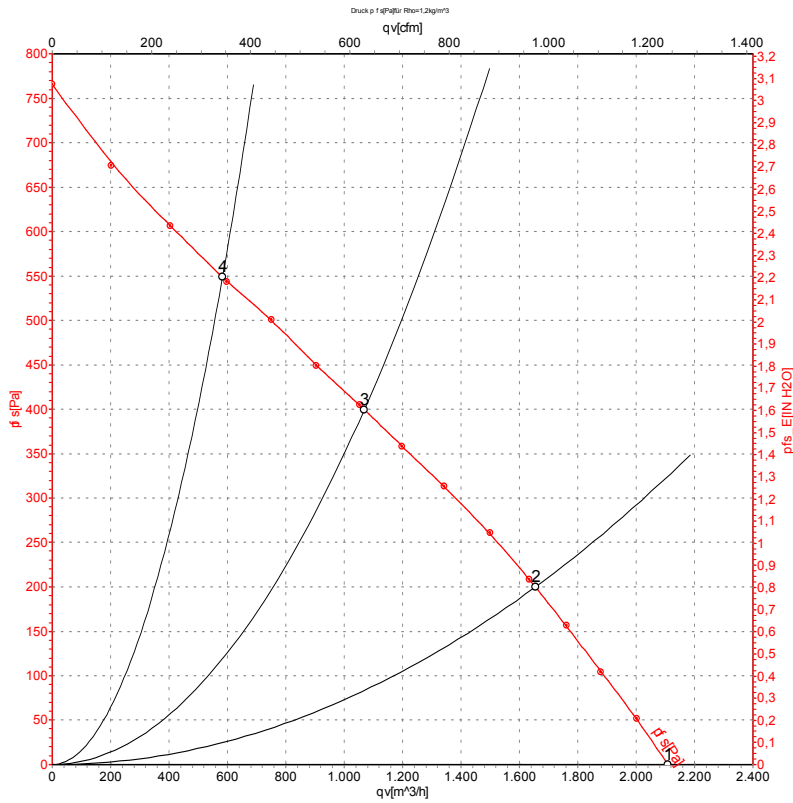

Air performance measured as per ISO 5801 Installation category A. For detailed information on the measuring set-up, please contact ebmpapst. Suction-side noise levels: L_{wA} measured as per ISO 13347 / L_{pA} measured with 1m distance to fan axis. The values given are valid under the measuring conditions mentioned above and may vary according to the actual installation situation. With any deviation from the standard set-up, the specific values have to be checked and reviewed with the unit installed.

Measured values

	U	f	n	P _e	I	qv	P _{fs}
	V	Hz	min ⁻¹	W	A	m ³ /h	Pa
1	230	50	2700	225	1.00	2110	0
2	230	50	2510	289	1.26	1655	200
3	230	50	2365	324	1.42	1070	400
4	230	50	2490	291	1.27	585	550

U = Supply voltage · f = Frequency · n = Speed · P_e = Power input · I = Current draw · qv = Air flow · P_{fs} = Pressure increase