

R2E250-AS47-09

# AC centrifugal fan

backward-curved

ASIA PACIFIC SHENGRUI LIMITED

Phone +00852 56261528

info@apacfan.com

www.apacfan.com

Limited partnership · Headquarters Muldingen

Amtsgericht (court of registration) Stuttgart · HRA 590344

General partner Elektrobau Muldingen GmbH · Headquarters Muldingen

Amtsgericht (court of registration) Stuttgart · HRB 590142

## Nominal data

Type	R2E250-AS47-09		
Motor	M2E068-EC		
Phase		1~	1~
Nominal voltage	VAC	230	230
Frequency	Hz	50	60
Method of obtaining data		fa	fa
Valid for approval/standard		-	-
Speed (rpm)	min <sup>-1</sup>	2600	2700
Power consumption	W	155	215
Current draw	A	0.70	0.95
Capacitor	µF	5	5
Capacitor voltage	VDB	400	400
Capacitor standard		S2 (CE)	S2 (CE)
Min. back pressure	Pa	0	0
Min. back pressure	in. wg	0	0
Min. ambient temperature	°C	-25	-25
Max. ambient temperature	°C	40	40
Starting current	A	1.3	1.3

ml = Max. load · me = Max. efficiency · fa = Free air · cs = Customer specification · ce = Customer equipment  
Subject to change



ebmpapst

R2E250-AS47-09

# AC centrifugal fan

backward-curved

## Technical description

<b>Weight</b>	3 kg
<b>Size</b>	250 mm
<b>Motor size</b>	68
<b>Rotor surface</b>	Painted black
<b>Impeller material</b>	PA plastic, glass-fiber reinforced
<b>Direction of rotation</b>	Clockwise, viewed toward rotor
<b>Degree of protection</b>	IP44; installation- and position-dependent as per EN 60034-5
<b>Insulation class</b>	"F"
<b>Moisture (F) / Environmental (H) protection class</b>	F2-2; H1+
<b>Max. permitted ambient temp. for motor (transport/storage)</b>	+ 80 °C
<b>Min. permitted ambient temp. for motor (transport/storage)</b>	- 40 °C
<b>Installation position</b>	Shaft horizontal or rotor on bottom; rotor on top on request
<b>Condensation drainage holes</b>	On rotor side
<b>Mode</b>	S1
<b>Motor bearing</b>	Ball bearing
<b>Touch current according to IEC 60990 (measuring circuit Fig. 4, TN system)</b>	< 0.75 mA
<b>Motor protection</b>	Thermal overload protector (TOP) internally connected
<b>With cable</b>	Variable
<b>Protection class</b>	I (with customer connection of protective earth)



## Product drawing

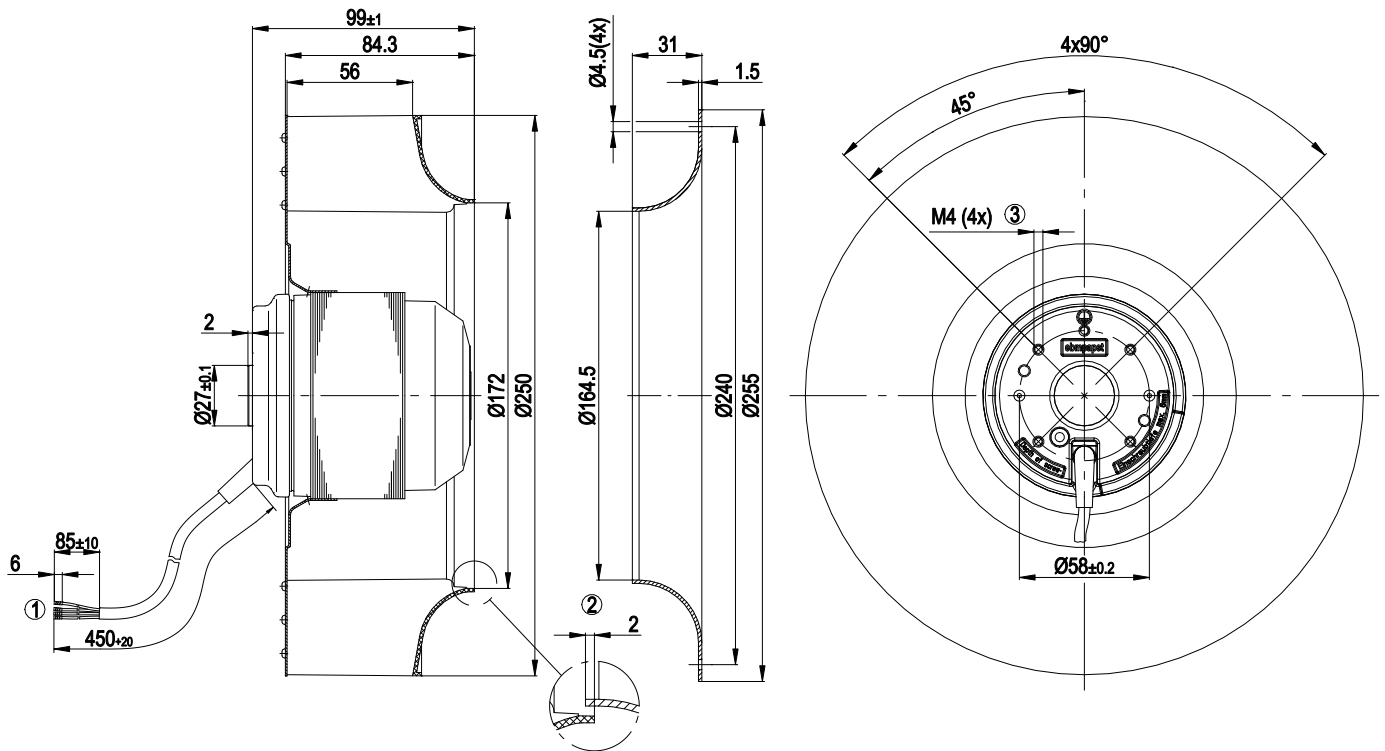

- |   |  |
|---|--|
| 1 | Cable 4G x 0.5 mm <sup>2</sup> . 4x crimped splices                        |
| 2 | Accessory part: Inlet ring 96359-2-4013, not included in scope of delivery |
| 3 | Max. clearance for screw 5 mm  |

## Connection diagram

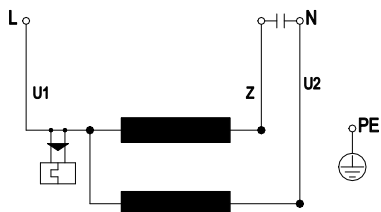

U1	blue	Z	brown	U2	black
PE	green/yellow				

## Curves: Air performance 50 Hz

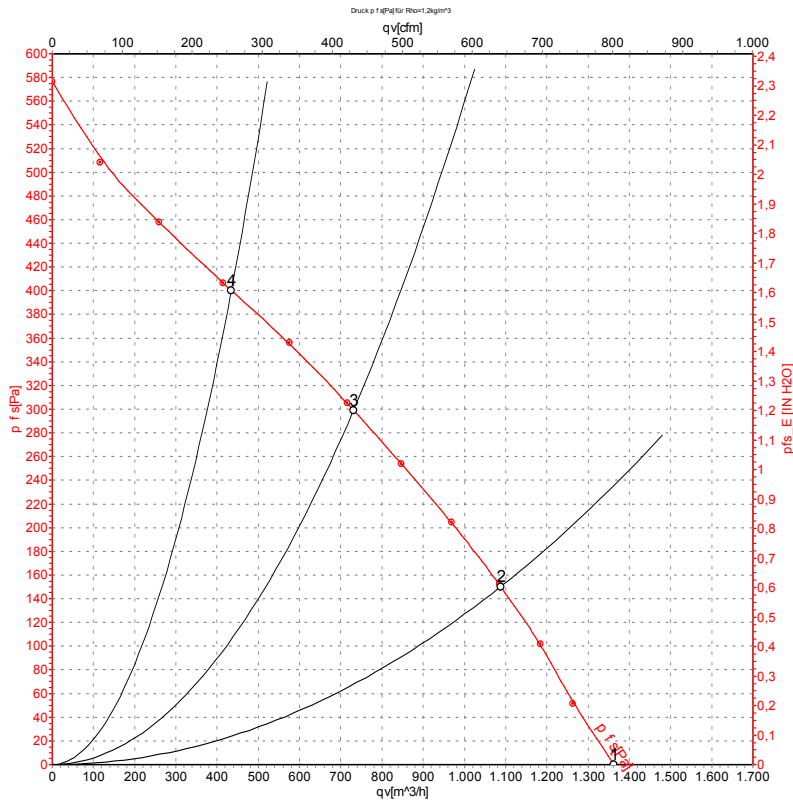

Measurement: LU-30851-1

Air performance measured according to ISO 5801 installation category A. For detailed information on the measurement setup, contact ebm-papst. Intake sound level: Sound power level according to ISO 13347 / sound pressure level measured at 1 m distance from fan axis. The values given are valid under the specified measuring conditions and may vary due to conditions of installation. For deviations from the standard configuration, the parameters have to be checked on the installed unit.

## Measured values

	U	f	n	P <sub>e</sub>	I	q <sub>V</sub>	P <sub>fs</sub>	q <sub>V</sub>	P <sub>fs</sub>
	V	Hz	min <sup>-1</sup>	W	A	m <sup>3</sup> /h	Pa	cfm	in. wg
1	230	50	2600	155	0.70	1365	0	800	0.00
2	230	50	2460	172	0.75	1090	150	640	0.60
3	230	50	2370	189	0.82	730	300	430	1.20
4	230	50	2430	177	0.77	435	400	255	1.61

U = Voltage · f = Frequency · n = Speed (rpm) · P<sub>e</sub> = Power consumption · I = Current draw · q<sub>V</sub> = Air flow · p<sub>fs</sub> = Pressure increase

## Curves: Air performance 60 Hz

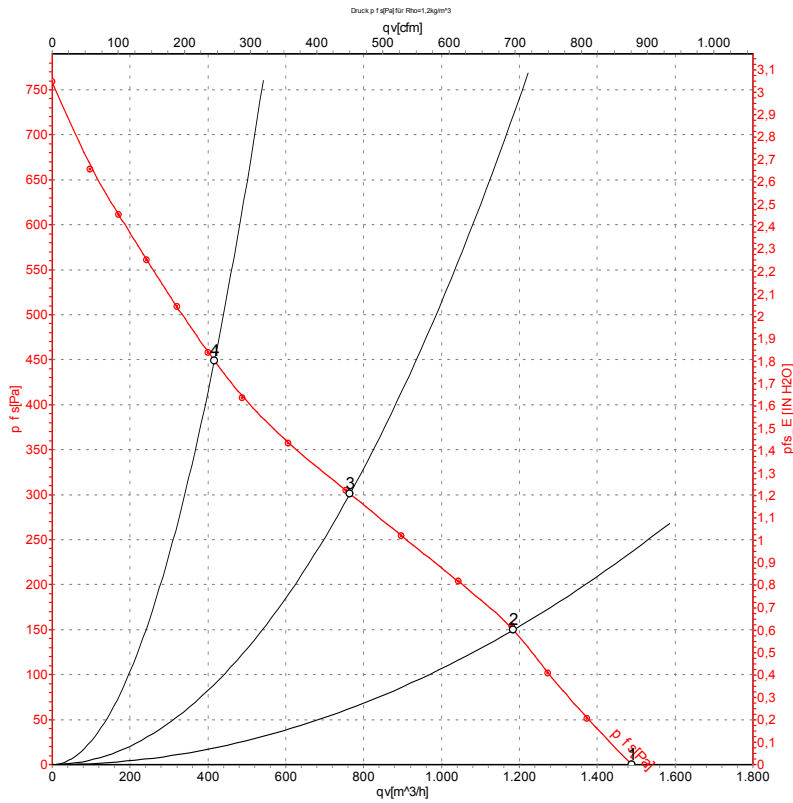

Measurement: LU-30852-1

Air performance measured according to ISO 5801 installation category A. For detailed information on the measurement setup, contact ebm-papst. Intake sound level: Sound power level according to ISO 13347 / sound pressure level measured at 1 m distance from fan axis. The values given are valid under the specified measuring conditions and may vary due to conditions of installation. For deviations from the standard configuration, the parameters have to be checked on the installed unit.

## Measured values

	U	f	n	P <sub>e</sub>	I	q <sub>v</sub>	P <sub>fs</sub>	q <sub>v</sub>	P <sub>fs</sub>
	V	Hz	min <sup>-1</sup>	W	A	m <sup>3</sup> /h	Pa	cfm	in. wg
1	230	60	2795	215	0.95	1490	0	875	0.00
2	230	60	2610	228	0.99	1185	150	695	0.60
3	230	60	2415	240	1.04	765	300	450	1.20
4	230	60	2560	231	1.00	415	450	245	1.81

U = Voltage · f = Frequency · n = Speed (rpm) · P<sub>e</sub> = Power consumption · I = Current draw · q<sub>v</sub> = Air flow · p<sub>fs</sub> = Pressure increase

