

ASIA PACIFIC SHENGRUI LIMITED

Phone +00852 56261528

info@apacfan.com

www.apacfan.com

Nominal data

Type	R2E225-BD92-19		
Motor	M2E068-DF		
Phase		1~	1~
Nominal voltage	VAC	230	230
Frequency	Hz	50	60
Type of data definition		fa	fa
Valid for approval / standard		-	-
Speed	min ⁻¹	2650	2950
Power input	W	135	200
Current draw	A	0.6	0.88
Motor capacitor	μF	4	4
Capacitor voltage	VDB	450	450
Min. back pressure	Pa	0	0
Min. ambient temperature	°C	-25	-25
Max. ambient temperature	°C	55	55
Starting current	A	1.2	1.2

ml = Max. load · me = Max. efficiency · fa = Running at free air · cs = Customer specs · cu = Customer unit
Subject to alterations



Technical features

Mass	2.3 kg
Size	225 mm
Surface of rotor	Coated in black
Material of impeller	Plastic PA6, fibreglass-reinforced
Number of blades	7
Direction of rotation	Clockwise, seen on rotor
Type of protection	IP 44
Insulation class	"F"
Humidity class	F1-2
Max. permissible ambient motor temp. (transp./ storage)	+ 80 °C
Min. permissible ambient motor temp. (transp./storage)	- 40 °C
Mounting position	Shaft horizontal or rotor on bottom; rotor on top on request
Condensate discharge holes	Rotor-side
Operation mode	S1
Motor bearing	Ball bearing
Touch current acc. IEC 60990 (measuring network Fig. 4, TN system)	< 0.75 mA
Motor protection	Thermal overload protector (TOP) wired internally
Cable exit	Variable
Protection class	I (if protective earth is connected by customer)
Product conforming to standard	EN 60335-1
Approval	UL 1004-1; CSA C22.2 Nr.100; CCC

Product drawing

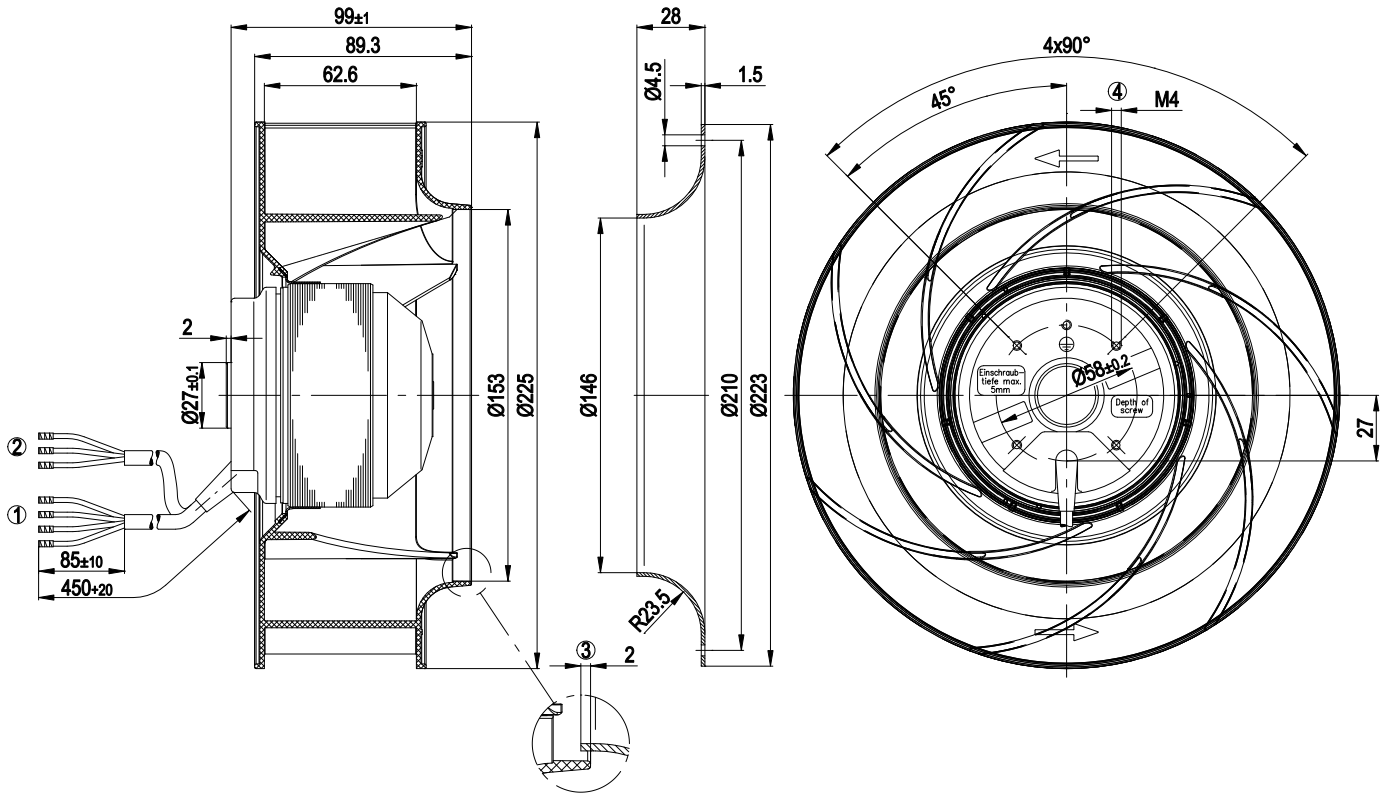

1	Connection line PVC, 4x brass lead tips crimped
2	Connection line, 3x brass lead tips crimped
3	Accessory part: Inlet nozzle 96358-2-4013, not included in the standard scope of delivery
4	Depth of screw max. 5 mm

Connection screen

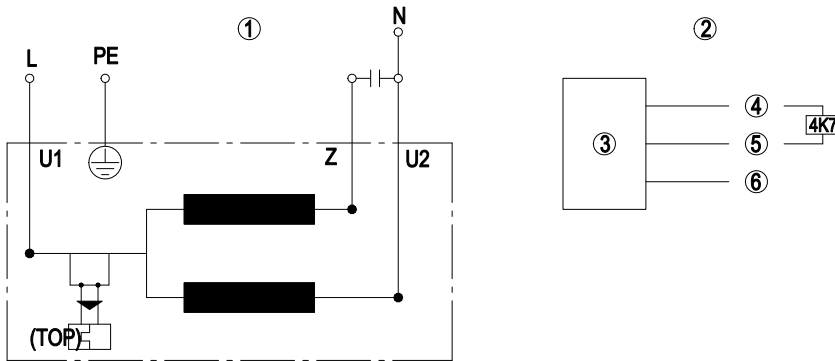

1	Fan connection diagram
TOP	Thermal overload protector
U1	blue
Z	brown
U2	black
PE	green/yellow
2	Hall IC circuit
3	Fan
4	Red (+5V)
5	White (out)
6	Black (0V)

Charts: Air flow 50 Hz

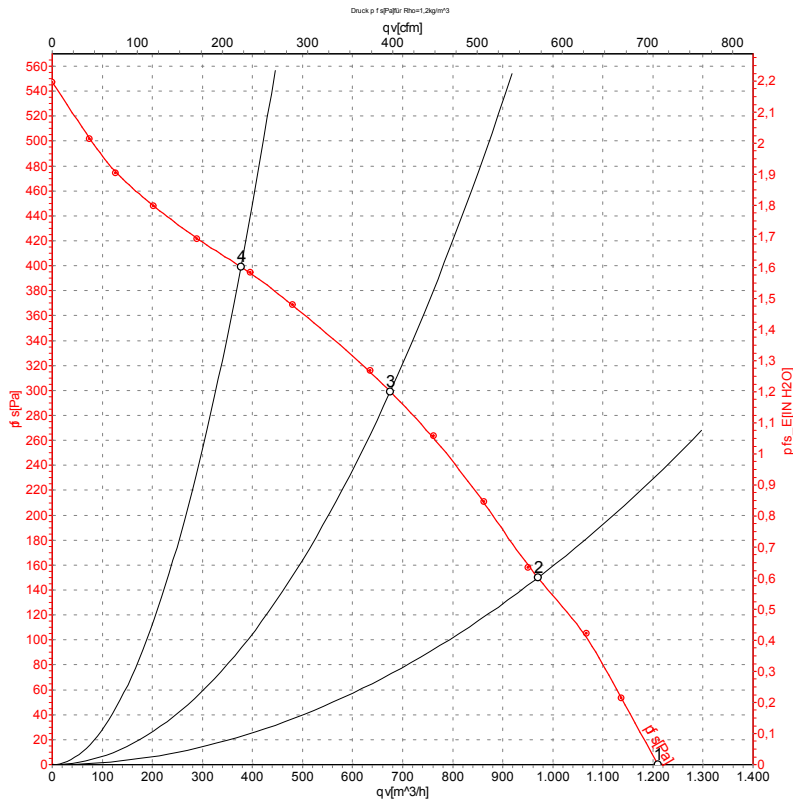

Measurement: LU-57084

Air performance measured as per ISO 5801 Installation category A. For detailed information on the measuring set-up, please contact ebm-papst. Suction-side noise levels: L_{wA} measured as per ISO 13347 / L_{pA} measured with 1m distance to fan axis. The values given are valid under the measuring conditions mentioned above and may vary according to the actual installation situation. With any deviation from the standard set-up, the specific values have to be checked and reviewed with the unit installed.

Measured values

	U	f	n	P _e	I	qv	P _{fs}
	V	Hz	min ⁻¹	W	A	m³/h	Pa
1	230	50	2700	135	0.60	1210	0
2	230	50	2660	138	0.60	970	150
3	230	50	2595	150	0.65	675	300
4	230	50	2645	140	0.61	375	400

U = Supply voltage · f = Frequency · n = Speed · P_e = Power input · I = Current draw · qv = Air flow · p_{fs} = Pressure increase



Charts: Air flow 60 Hz

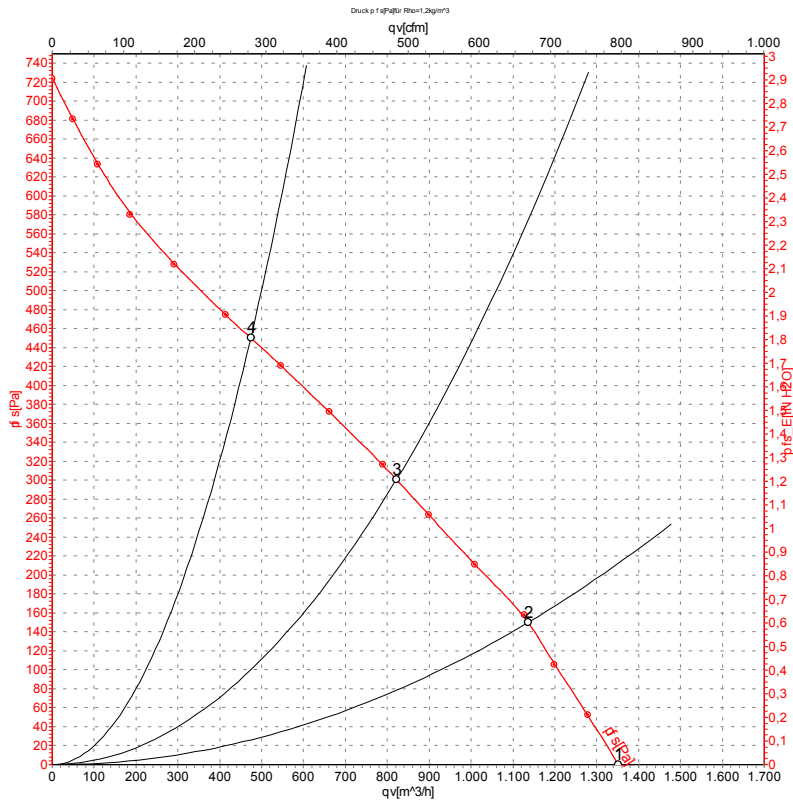

Measurement: LU-57085

Air performance measured as per ISO 5801 Installation category A. For detailed information on the measuring set-up, please contact ebmpapst. Suction-side noise levels: LwA measured as per ISO 13347 / LpA measured with 1m distance to fan axis. The values given are valid under the measuring conditions mentioned above and may vary according to the actual installation situation. With any deviation from the standard set-up, the specific values have to be checked and reviewed with the unit installed.

Measured values

	U	f	n	P _e	I	qv	P _{fs}
	V	Hz	min ⁻¹	W	A	m ³ /h	Pa
1	230	60	2950	200	0.88	1350	0
2	230	60	2910	207	0.91	1135	150
3	230	60	2795	216	0.94	820	300
4	230	60	2845	210	0.92	475	450

U = Supply voltage · f = Frequency · n = Speed · P_e = Power input · I = Current draw · qv = Air flow · P_{fs} = Pressure increase

