

R2E190-AO26-30

AC centrifugal fan

backward-curved, single-intake



ASIA PACIFIC SHENGRUI LIMITED

Phone +00852 56261528

info@apacfan.com

www.apacfan.com

Nominal data

Type	R2E190-AO26-30			
Motor	M2E068-BF			
Phase		1~	1~	1~
Nominal voltage	VAC	230	230	230
Frequency	Hz	50	60	60
Method of obtaining data		fa	fa	fa
Valid for approval/standard		CE	CE	UL 2111
Speed (rpm)	min ⁻¹	2500	2700	2700
Power consumption	W	58	75	80
Current draw	A	0.26	0.34	0.35
Capacitor	μF	2	2	2
Capacitor voltage	VDB	400	400	400
Min. back pressure	Pa	0	0	0
Min. back pressure	in. wg	0	0	0
Min. ambient temperature	°C	-25	-25	-25
Max. ambient temperature	°C	50	55	55
Starting current	A	0.40	0.41	

ml = Max. load · me = Max. efficiency · fa = Free air · cs = Customer specification · ce = Customer equipment
Subject to change



Technical description

Weight	1.2 kg
Size	190 mm
Motor size	68
Rotor surface	Painted black
Impeller material	PA plastic
Number of blades	7
Direction of rotation	Clockwise, viewed toward rotor
Degree of protection	IP44; installation- and position-dependent
Insulation class	"B"
Moisture (F) / Environmental (H) protection class	H1
Max. permitted ambient temp. for motor (transport/storage)	+ 80 °C
Min. permitted ambient temp. for motor (transport/storage)	- 40 °C
Installation position	Any
Condensation drainage holes	None
Mode	S1
Motor bearing	Ball bearing
Touch current according to IEC 60990 (measuring circuit Fig. 4, TN system)	< 0.75 mA
Motor protection	Thermal overload protector (TOP) internally connected
With cable	Variable
Protection class	I (if the protective earth is connected by the customer to the marked PE connection point)
Conformity with standards	EN 60034-1; EN 60204-1; CE
Approval	UL 1004-3; CCC; CSA C22.2 No. 77

Product drawing

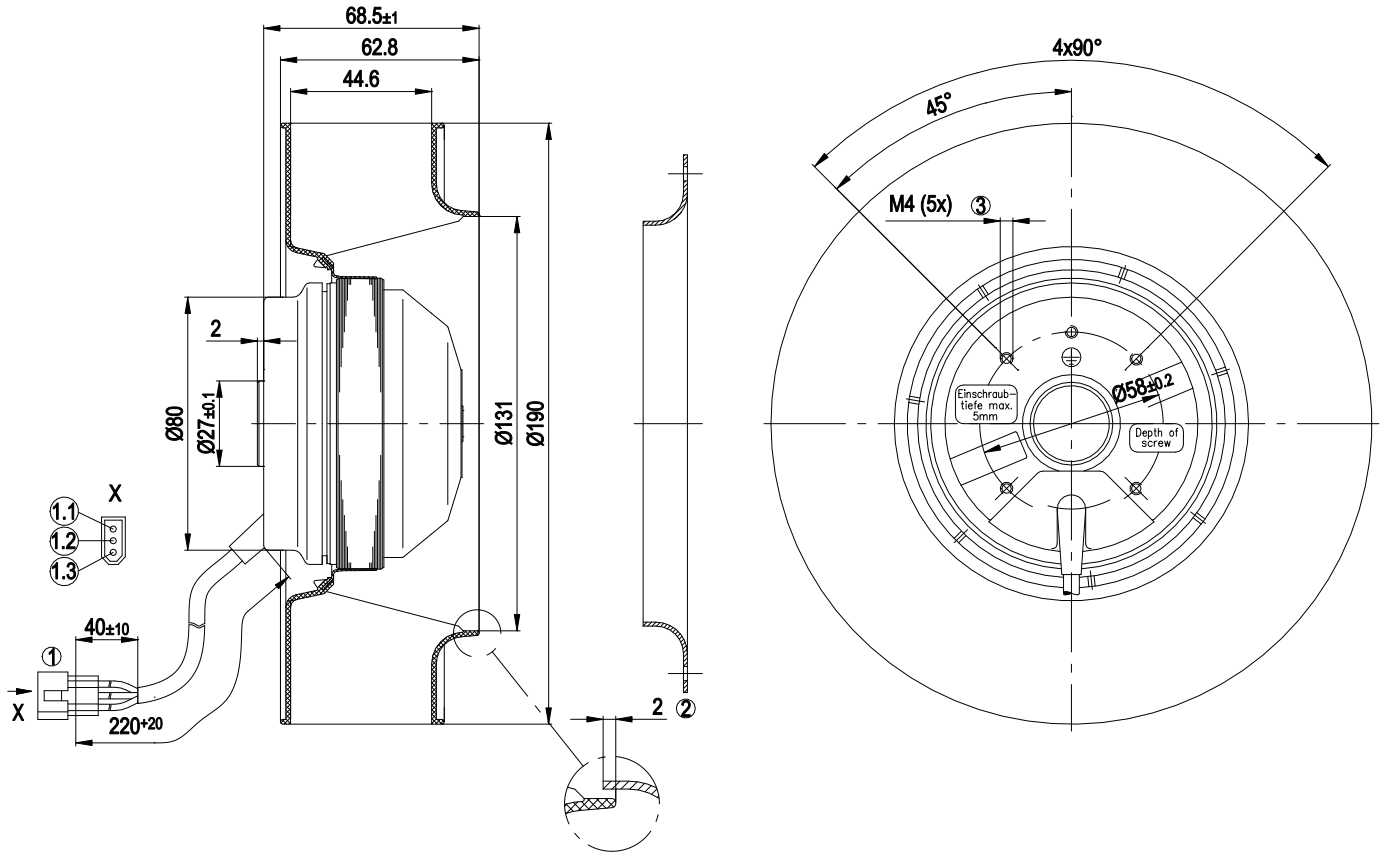

1	Connector housing Molex 03-06-2032, cable PVC AWG20 with 3 x plug pin Molex 02-06-2201
1.1	brown
1.2	black
1.3	blue
2	Accessory part: Inlet ring 09576-2-4013, not included in scope of delivery
3	Max. clearance for screw 5 mm

Accessory part

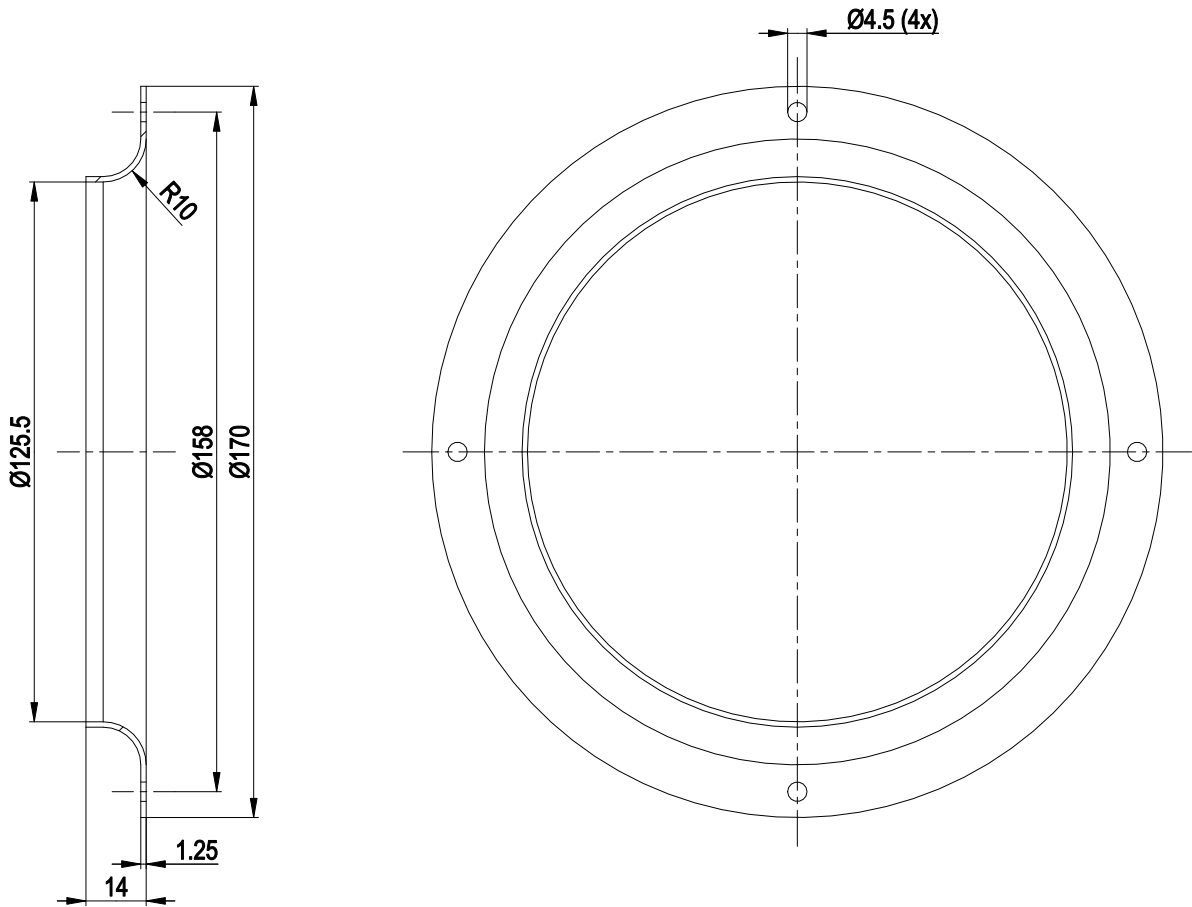

1 Accessory part: inlet ring 09576-2-4013 not included in scope of delivery

Connection diagram

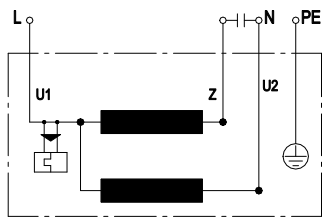

U1	blue	Z	brown	U2	black
PE	green/yellow				

Curves: Air performance 50 Hz

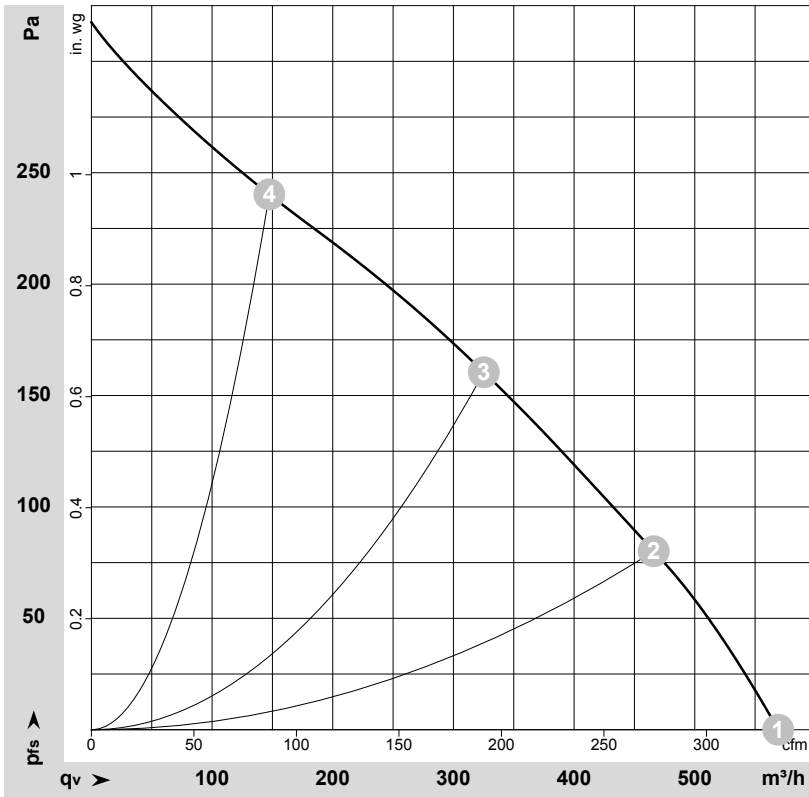

$\rho = 1.15 \text{ kg/m}^3 \pm 2 \%$

Measurement: LU-53162-1

Air performance measured according to ISO 5801 installation category A. For detailed information on the measurement setup, contact ebmpapst. Intake sound level: Sound power level according to ISO 13347 / sound pressure level measured at 1 m distance from fan axis. The values given are valid under the specified measuring conditions and may vary due to conditions of installation. For deviations from the standard configuration, the parameters have to be checked on the installed unit.

Measured values

	Wired	U	f	n	Pe	I	qv	Pfs	qv	Pfs
		V	Hz	min ⁻¹	W	A	m ³ /h	Pa	cfm	in. wg
1	1~	230	50	2500	58	0.26	570	0	335	0.00
2	1~	230	50	2470	60	0.26	465	80	275	0.32
3	1~	230	50	2415	61	0.27	325	160	190	0.64
4	1~	230	50	2515	58	0.25	145	240	85	0.96

Wired = Wiring · U = Voltage · f = Frequency · n = Speed (rpm) · Pe = Power consumption · I = Current draw · qv = Air flow · Pfs = Pressure increase

Curves: Air performance 60 Hz

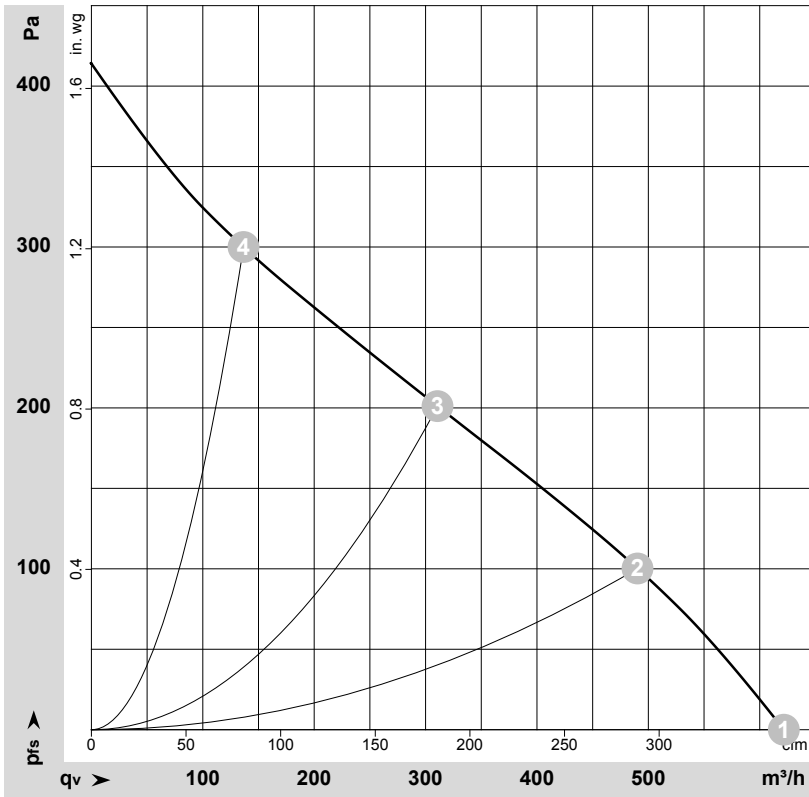

$\rho = 1.15 \text{ kg/m}^3 \pm 2 \%$

Measurement: LU-53163-1

Air performance measured according to ISO 5801 installation category A. For detailed information on the measurement setup, contact ebmpapst. Intake sound level: Sound power level according to ISO 13347 / sound pressure level measured at 1 m distance from fan axis. The values given are valid under the specified measuring conditions and may vary due to conditions of installation. For deviations from the standard configuration, the parameters have to be checked on the installed unit.

Measured values

	Wired	U	f	n	P _e	I	q _v	P _{fs}	q _v	P _{fs}
		V	Hz	min ⁻¹	W	A	m ³ /h	Pa	cfm	in. wg
1	1~	230	60	2700	75	0.34	620	0	365	0.00
2	1~	230	60	2690	76	0.34	490	100	290	0.40
3	1~	230	60	2570	79	0.35	310	200	185	0.80
4	1~	230	60	2780	74	0.33	135	300	80	1.20

Wired = Wiring · U = Voltage · f = Frequency · n = Speed (rpm) · P_e = Power consumption · I = Current draw · q_v = Air flow · P_{fs} = Pressure increase