

R2E133-BH66-05

AC centrifugal fan

backward curved



ASIA PACIFIC SHENGRUI LIMITED

Phone +00852 56261528

info@apacfan.com

www.apacfan.com

Nominal data

Type	R2E133-BH66-05		
Motor	M2E052-BF		
Phase		1~	1~
Nominal voltage	[V]	230	230
Frequency	[Hz]	50	60
Type of data definition		rfa	rfa
Valid for approval / standard		CE	CE
Speed	[min ⁻¹]	2800	3300
Power input	[W]	24	27
Current draw	[A]	0.11	0.13
Motor capacitor	[μF]	1	1
Capacitor voltage	[VDB]	400	400
Capacitor standard		P0 (CE)	P0 (CE)
Min. back pressure	[Pa]	0	0
Max. ambient temperature	[°C]	45	60

ml = max. load · me = max. efficiency · rfa = running at free air · cs = customer specs · cu = customer unit
Subject to alterations

Technical features

Leakage current	< 0.75 mA
Size	133 mm
Operation mode	S1
Direction of rotation	Clockwise, seen on rotor
Mounting position	Any
Insulation class	"B"
Cable exit	Variable
Condensate discharge holes	None
Bearing motor	Ball bearing
Mass	0.7 kg
Material of impeller	PA plastic 6, fiberglass-reinforced
Motor protection	Thermal overload protector (TOP) wired internally
Product conforming to standard	CE
Surface of rotor	Partially cast in aluminium
Number of blades	7
Type of protection	IP 44; Depending on installation and position
Protection class	I
Max. permissible ambient motor temp. (transp./ storage)	+ 80 °C
Min. permissible ambient motor temp. (transp./storage)	- 40 °C
Approval	CCC; GOST

Product drawing

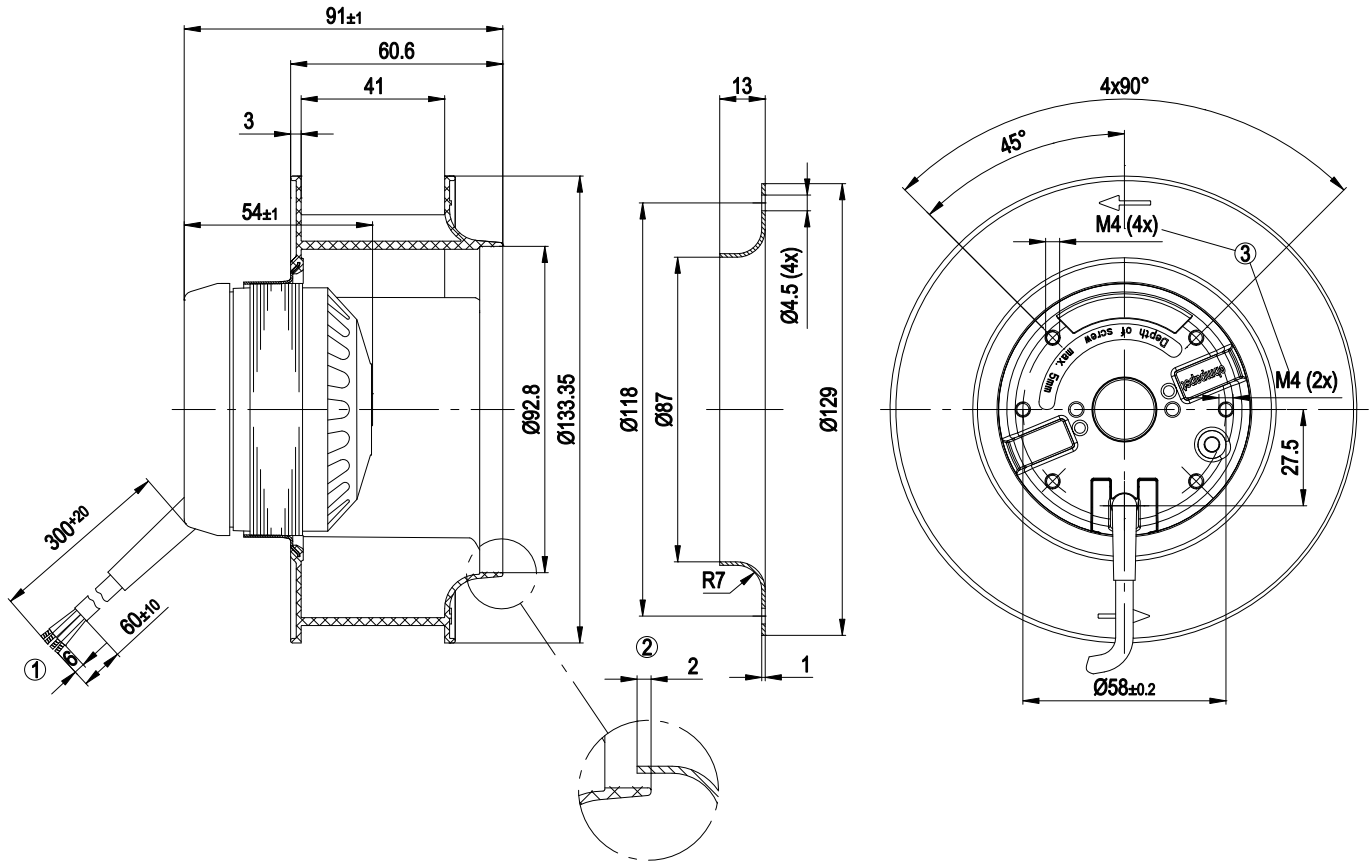

1	Connection line PVC, 4x brass lead tips crimped
2	Accessory part: Inlet nozzle 09566-2-4013, not included in the standard scope of delivery
3	Screw depth max. 5 mm

Connection screen

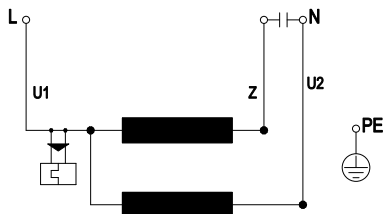

U1	blue	Z	brown	U2	black
PE	green/yellow				

Charts: Air flow 50 Hz

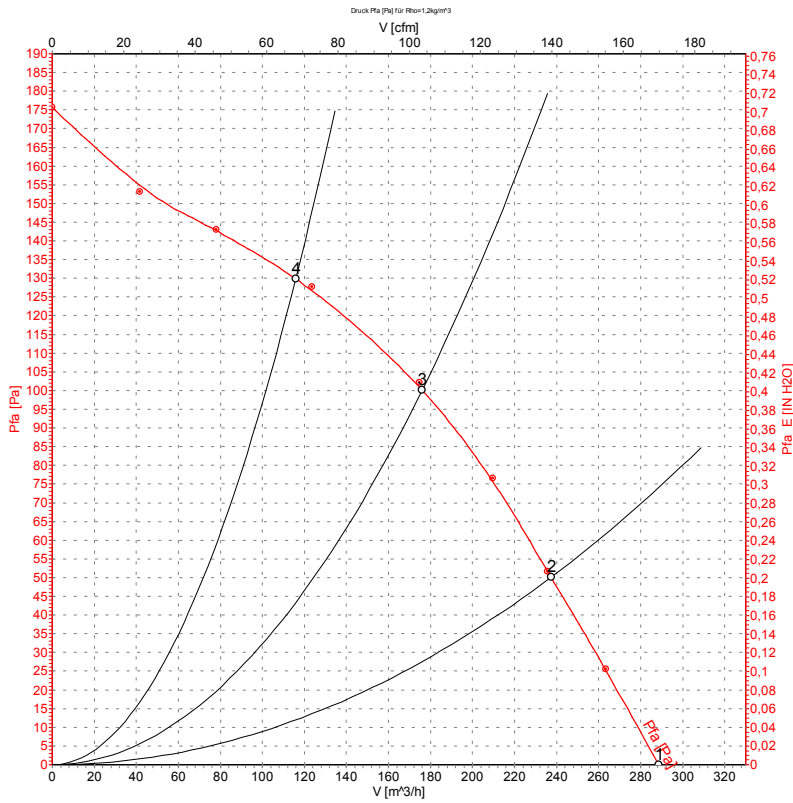

Measurement: LU-54086

Measured values

	U	f	n	P ₁	I	\hat{V}	P _{fa}
	[V]	[Hz]	[min ⁻¹]	[W]	[A]	[m ³ /h]	[Pa]
1	230	50	2800	24	0.11	290	0
2	230	50	2710	25	0.11	235	50
3	230	50	2700	26	0.11	175	100
4	230	50	2710	26	0.11	115	130

Charts: Air flow 60 Hz

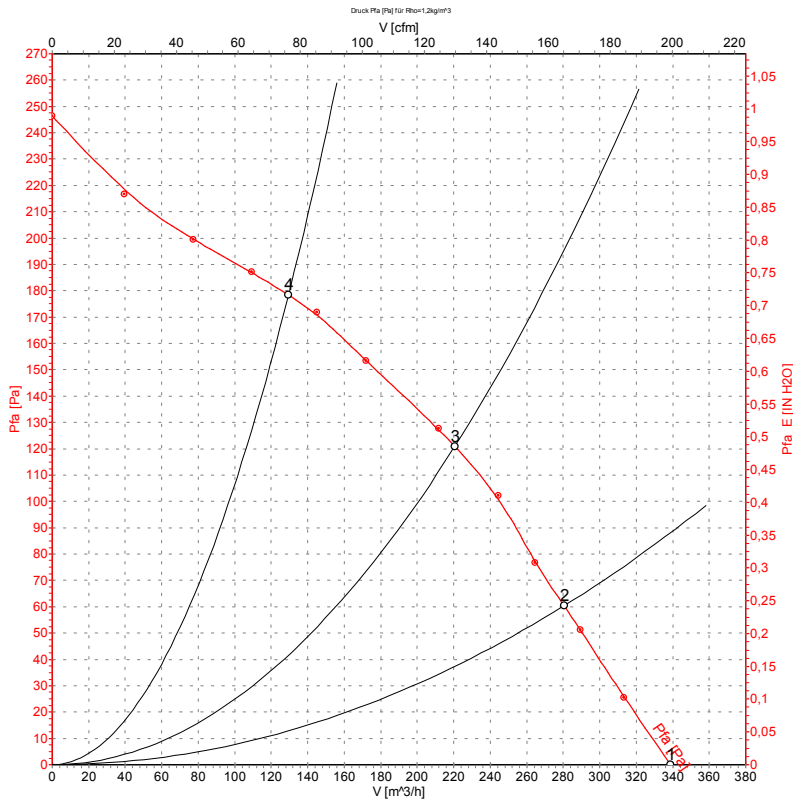

Measured values

	U	f	n	P ₁	I	\hat{V}	P _{fa}
	[V]	[Hz]	[min ⁻¹]	[W]	[A]	[m ³ /h]	[Pa]
1	230	60	3235	27	0.13	340	0
2	230	60	3150	29	0.13	280	60
3	230	60	3125	29	0.13	220	120
4	230	60	3145	29	0.13	130	180