

ASIA PACIFIC SHENGRUI LIMITED  
 Phone +00852 56261528  
 info@apacfan.com  
 www.apacfan.com

## CONTENTS

<b>1. SAFETY REGULATIONS AND INFORMATION</b>	<b>1</b>
1.1 Hazard levels for warnings	1
1.2 Staff qualifications	1
1.3 Basic safety rules	1
1.4 Voltage	1
1.5 Electromagnetic radiation	2
1.6 Mechanical movement	2
1.7 Hot surface	2
1.8 Transport	2
1.9 Storage	2
<b>2. INTENDED USE</b>	<b>3</b>
<b>3. TECHNICAL DATA</b>	<b>4</b>
3.1 Product drawing	4
3.2 Nominal data	5
3.3 Technical description	5
3.4 Mounting data	5
3.5 Transport and storage conditions	5
<b>4. CONNECTION AND STARTUP</b>	<b>6</b>
4.1 Mechanical connection	6
4.2 Electrical connection	6
4.3 Connecting the cables	6
4.4 Connection diagram	7
4.5 Checking connections	8
4.6 Switching on the device	8
4.7 Switching off the device	8
<b>5. MAINTENANCE, MALFUNCTIONS, POSSIBLE CAUSES AND REMEDIES</b>	<b>8</b>
5.1 Cleaning	8
5.2 Safety inspection	8
5.3 Disposal	8

## 1. SAFETY REGULATIONS AND INFORMATION

Read these operating instructions carefully before starting work on the device. Observe the following warnings to prevent malfunctions or danger to persons.

These operating instructions are to be regarded as part of the device. The device is only to be sold or passed on together with the operating instructions.

These operating instructions may be duplicated and distributed to inform about potential dangers and their prevention.

### 1.1 Hazard levels for warnings

These operating instructions use the following hazard levels to indicate potentially hazardous situations and important safety regulations:



#### **DANGER**

Indicates an imminently hazardous situation which will result in death or serious injury if the specified actions are not taken. Compliance with the instructions is imperative.

#### **WARNING**

Indicates a potentially hazardous situation which can result in death or serious injury if the specified actions are not taken. Exercise extreme caution while working.

#### **CAUTION**

Indicates a potentially hazardous situation which can result in minor or moderate injury or damage to property if the specified actions are not taken.

#### **NOTE**

A potentially harmful situation can occur and, if not avoided, can lead to property damage.

### 1.2 Staff qualifications

The device may only be transported, unpacked, installed, operated, maintained and otherwise used by suitably qualified, trained and authorized technical staff.

Only authorized specialists are permitted to install the device, to carry out a test run and to perform work on the electrical installation.

### 1.3 Basic safety rules

The safety hazards associated with the device must be assessed again following installation in the final product.

The locally applicable industrial safety regulations are always to be observed when working on the device.

Keep the workplace clean and tidy. Untidiness in the work area increases the risk of accidents.

Note the following when working on the device:

- ⇒ Do not perform any modifications, additions or conversions on the device without the approval of ebm-papst.

### 1.4 Voltage

- ⇒ Check the device's electrical equipment at regular intervals; see Chapter 5.2 Safety inspection.

- ⇒ Replace loose connections and defective cables immediately.



#### **DANGER**

#### **Electrically charged device**

Risk of electric shock

- When working on an electrically charged device, stand on a rubber mat.

**WARNING****Live terminals and connections even with device switched off**

Electric shock

- Wait five minutes after disconnecting the voltage at all poles before opening the device.

**CAUTION****In the event of a fault, the rotor and the impeller will be energized**

The rotor and the impeller have basic insulation.

- Do not touch the rotor and impeller once installed.

**CAUTION****The motor restarts automatically when operating voltage is applied, e.g. after a power failure.**

Risk of injury

- Keep out of the motor's danger zone.
- When working on the motor, switch off the line voltage and ensure that it cannot be switched back on.
- Wait until the motor comes to a stop.

**1.5 Electromagnetic radiation**

Interference from electromagnetic radiation is possible, e.g. in conjunction with open- and closed-loop control devices.

If impermissible radiation levels occur following installation, appropriate shielding measures have to be taken by the user.

**NOTE****Electrical or electromagnetic interference after installing the device in customer equipment.**

- Verify that the entire setup is EMC-compliant.

**1.6 Mechanical movement****WARNING****Rotating device**

Long hair and dangling items of clothing, jewelry and the like can become entangled and be pulled into the device. Injuries can result.

- Do not wear any loose-fitting or dangling clothing or jewelry while working on rotating parts.
- Protect long hair with a cap.

**WARNING****Ejected parts**

If the motor is operated with attached fan blades, missing protective devices may allow balancing weights or broken fan blades to be ejected and cause injuries.

- Take appropriate safety measures such as installing guard grilles.
- Keep out of the exhaust zone.

**1.7 Hot surface****CAUTION****High temperature on motor housing**

Risk of burns

- Ensure sufficient protection against accidental contact.

**1.8 Transport****CAUTION****Transporting the motor**

Crushing hazard



- Wear safety shoes and cut-resistant safety gloves.

- Transport the motor in its original packaging only.

- Secure the device so it cannot slip, e.g. by using a lashing strip.

**1.9 Storage**

- ⇒ Store the device, partially or fully assembled, in a dry place, protected against the weather and free from vibration, in the original packaging in a clean environment.
- ⇒ Protect the device against environmental effects and dirt until final installation.
- ⇒ We recommend storing the device for no longer than one year in order to guarantee trouble-free operation and the longest possible service life.
- ⇒ Even devices explicitly intended for outdoor use are to be stored as described prior to commissioning.
- ⇒ Maintain the storage temperature, see Chapter 3.5 Transport and storage conditions.

## 2. INTENDED USE

The device is designed exclusively for use as a drive motor. Any other usage above and beyond this does not conform with the intended purpose and constitutes misuse of the device. Customer equipment must be capable of withstanding the mechanical and thermal stresses that can arise from this product. This applies for the entire service life of the equipment in which this product is installed.

### Intended use also includes

- Using the device within the permitted ambient temperature range; see Chapter 3.5 Transport and storage conditions and Chapter 3.2 Nominal data.
- Operating the device with all protective devices.
- Following the operating instructions.

### Improper use

In particular, operating the device in the following ways is prohibited and could be hazardous:

- Resonant operation, operation with severe vibration/oscillation. This also includes vibration transmitted to the motor from the customer installation.
- Operation in medical equipment with a life-sustaining or life-support function.
- Conveying solids in the flow medium.
- Painting the device
- Connections (e.g. screws) coming loose during operation.
- Conveying air that contains abrasive particles.
- Conveying highly corrosive air, e.g. salt spray. Exception: devices designed for salt spray and correspondingly protected.
- Conveying air with high dust content, e.g. suctioning off sawdust.
- Operating the device close to flammable materials or components.
- Operating the device in an explosive atmosphere.
- Using the device as a safety component or to perform safety-related functions.
- Operation with completely or partially disassembled or manipulated protective devices.
- In addition, all applications not listed among the intended uses.

## 3. TECHNICAL DATA

## 3.1 Product drawing

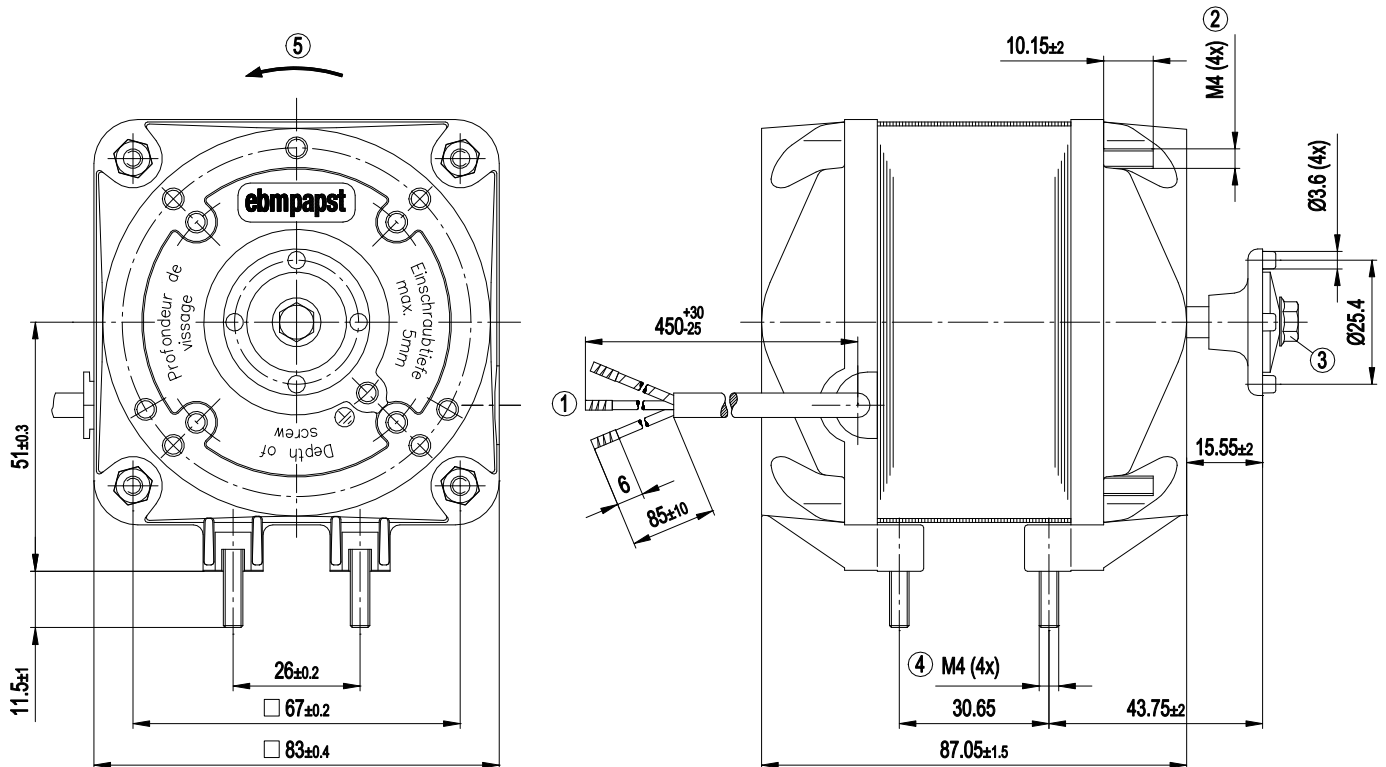

All dimensions in mm.

1	Cable PVC 3G 0.5 mm <sup>2</sup> , 3x crimped splices
2	Tightening torque for nuts to fasten fan housing or guard grille: 2.3 Nm
3	Tightening torque for screw to fasten fan impeller: 1.4 Nm
4	Tightening torque for nuts to fasten mounting bracket: 2.3 Nm
5	Direction of rotation counterclockwise, viewed toward shaft end

## 3.2 Nominal data

<b>Motor</b>	M4Q045-EA	
<b>Phase</b>	1~	1~
<b>Nominal voltage / VAC</b>	230	230
<b>Frequency / Hz</b>	50	60
<b>Method of obtaining data</b>	me	me
<b>Valid for approval/standard</b>	CE	CE
<b>Speed (rpm) / min<sup>-1</sup></b>	1300	1550
<b>Power consumption / W</b>	90	80
<b>Power output / W</b>	25	26
<b>Current draw / A</b>	0.62	0.55
<b>Rated torque / Ncm</b>	18.5	16
<b>Mean starting torque / Ncm</b>	8.5	6.5
<b>Min. ambient temperature / °C</b>	-20	-20
<b>Max. ambient temperature / °C</b>	40	40
<b>Starting current / A</b>	0.9	0.75

ml = Max. load · me = Max. efficiency · fa = Free air  
 cs = Customer specification · ce = Customer equipment

Subject to change

## 3.3 Technical description

<b>Weight</b>	1.87 kg
<b>Motor size</b>	45
<b>Bearing shield material</b>	Die-cast aluminum
<b>Direction of rotation</b>	Counterclockwise, viewed toward rotor
<b>Degree of protection</b>	IP42; installation- and position-dependent
<b>Insulation class</b>	"B"
<b>Moisture (F) / Environmental (H) protection class</b>	H1
<b>Installation position</b>	Shaft horizontal
<b>Condensation drainage holes</b>	None
<b>Mode</b>	S1
<b>Motor bearing</b>	Calotte bearing
<b>Touch current according to IEC 60990 (measuring circuit Fig. 4, TN system)</b>	< 0.75 mA
<b>Motor protection</b>	Thermal overload protector (TOP) internally connected
<b>with cable</b>	Lateral
<b>Protection class</b>	I (with customer connection of protective earth)
<b>Conformity with standards</b>	EN 60335-1; CE
<b>Approval</b>	EAC; VDE



With regard to cyclic speed loads, note that the rotating parts of the device are designed for a maximum of one million load cycles. If you have special questions, consult ebm-papst for support.

⇒ Use the device in accordance with its degree of protection.

## Information on surface quality

The surfaces of the products conform to the generally applicable industrial standard. The surface quality may change during the production period. This has no effect on strength, dimensional stability and dimensional accuracy.

The color pigments in the paints used perceptibly react to UV light over the course of time. This does not however in any way affect the technical properties of the products. The product is to be protected against UV radiation to prevent the formation of patches and fading. Changes in color are not a reason for complaint and are not covered by the warranty.

## 3.4 Mounting data

<b>Strength class of screws</b>	8.8
---------------------------------	-----

For screw clearance, see Chapter 3.1 Product drawing

⇒ Secure the screws against unintentional loosening (e.g. use self-locking screws).

Any further mounting data required can be taken from the product drawing or Section Chapter 4.1 Mechanical connection.

## 3.5 Transport and storage conditions

<b>Max. permitted ambient temp. for motor (transport/storage)</b>	+ 80 °C
<b>Min. permitted ambient temp. for motor (transport/storage)</b>	- 40 °C

## 4. CONNECTION AND STARTUP

### 4.1 Mechanical connection



#### WARNING

##### Hot motor housing

Risk of fire

→ Ensure that no combustible or flammable materials are located close to the motor.



#### CAUTION

##### Cutting and crushing hazard when removing motor from packaging



→ Carefully remove the device from its packaging. Strictly avoid shocks.

→ Wear safety shoes and cut-resistant safety gloves.

⇒ Check the device for transport damage. Damaged devices are not to be installed.

⇒ Install the undamaged device in accordance with your application.



#### CAUTION

##### Possible damage to the device

If the device slips during installation, serious damage can result.

→ Ensure that the device is securely positioned at its place of installation until all fastening screws have been tightened.

### 4.2 Electrical connection



#### DANGER

##### Voltage on the device

Electric shock

→ Always connect a protective earth first.

→ Check the protective earth.



#### DANGER

##### Faulty insulation

Risk of fatal injury from electric shock

→ Use only cables that meet the specified installation regulations for voltage, current, insulation material, capacity, etc.

→ Route cables so that they cannot be touched by any rotating parts.



#### DANGER

##### Electrical charge (>50 µC) between phase conductor and protective earth connection after switching off supply with multiple devices connected in parallel.

Electric shock, risk of injury

→ Ensure sufficient protection against accidental contact. Before working on the electrical hookup, short the supply and PE connections.

#### NOTE

##### Water ingress into wires or cables

Water ingress at the customer end of the cable can damage the device.

→ Make sure the end of the cable is connected in a dry environment.



Only connect the device to circuits that can be switched off with an all-pole disconnection switch.

### 4.2.1 Requirements

⇒ Check whether the information on the nameplate matches the connection data.

⇒ Before connecting the device, make sure the power supply matches the device voltage.

⇒ Only use cables designed for the current level indicated on the nameplate.

For determining the cross-section, note the sizing criteria according to EN 61800-5-1. The protective earth must have a cross-section equal to or greater than that of the phase conductor.

We recommend the use of 105 °C cables. Ensure that the minimum cable cross-section is at least AWG 26 / 0.13 mm<sup>2</sup>.

### Protective earth contact resistance according to EN 60335

Compliance with the resistance specifications according to EN 60335 for the protective earth connection circuit must be verified in the end application. Depending on the installation situation, it may be necessary to connect an additional protective earth conductor by way of the extra protective earth terminal provided on the device.

### 4.2.2 Voltage control



#### NOTE

Current overshoots may occur if speed control is implemented by transformers or electronic voltage regulators (e.g. phase control). Depending on the type of installation of the device, noise and vibration may also occur in the case of phase control. Vibration can lead to bearing damage and thus premature failure.

Heating-up of the motor when using voltage control must be checked by the customer following installation in the end device.

### 4.2.3 Variable frequency drive

Please use a variable frequency drive only after consultation with ebmpapst.



For operation with variable frequency drives, install sinusoidal filters that work on all poles (phase-phase and phase-ground) between the drive and the motor.

During operation with variable frequency drives, an all-pole sine filter protects the motor against high-voltage transients that can destroy the coil insulation system, and against harmful bearing currents.

Heating-up of the motor when using a variable frequency drive must be checked by the customer following installation in the end device.

### 4.3 Connecting the cables

The device has external leads.

⇒ First connect the "PE" (protective earth).

• Connect the cables according to your application. When doing so, observe Chapter 4.4 Connection diagram.

## 4.4 Connection diagram

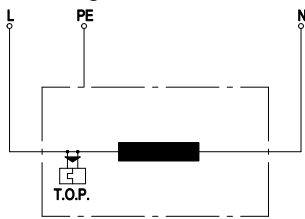

<b>L</b>	= blue
<b>PE</b>	= green/yellow
<b>N</b>	= brown
<b>TOP</b>	= thermal overload protector

#### 4.5 Checking connections

- ⇒ Ensure isolation from supply (all phases).
- ⇒ Make sure a restart is impossible
- ⇒ Check the cables for proper fit.

#### 4.6 Switching on the device

The device may only be switched on if it has been installed properly and in accordance with its intended use, including the required safety mechanisms and professional electrical hookup. This also applies for devices which have already been equipped with plugs and terminals or similar connectors by the customer.

- ⇒ Before switching on, check the device for visible external damage and make sure the protective devices are functional.
- ⇒ Check the fan's air flow paths for foreign matter and remove any foreign matter found.
- ⇒ Apply the nominal supply voltage.

#### 4.7 Switching off the device

- ⇒ Disconnect the device from the power supply at the supply line's main switch.
- ⇒ When disconnecting, be sure to disconnect the ground connection last.

### 5. MAINTENANCE, MALFUNCTIONS, POSSIBLE CAUSES AND REMEDIES

Do not perform any repairs on your device. Send the device to ebm-papst for repair or replacement.



#### WARNING

**Live terminals and connections even with device switched off**

Electric shock

- Wait five minutes after disconnecting the voltage at all poles before opening the device.

#### CAUTION

**The motor restarts automatically when operating voltage is applied, e.g. after a power failure.**

Risk of injury

- Keep out of the motor's danger zone.
- When working on the motor, switch off the line voltage and ensure that it cannot be switched back on.
- Wait until the motor comes to a stop.



If the device is out of use for some time, e.g. when in storage, we recommend switching it on for at least two hours to allow any condensation to evaporate and to move the bearings.

Malfunction/fault	Possible cause	Possible remedy
<b>Rotor not running smoothly</b>	Imbalance in rotating parts	Clean the device; replace it if imbalance persists after cleaning
<b>Motor not turning</b>	Mechanical blockage	Switch off, isolate from supply and remove mechanical blockage.
	Line voltage faulty	Check line voltage, restore power supply.

	Faulty connection	Isolate from supply, correct connection; see connection diagram.
	Thermal overload protector activated	Allow motor to cool off, locate and rectify cause of error, release restart lockout if necessary
	Impermissible point of operation	Check point of operation
<b>Motor overtemperature</b>	Ambient temperature too high	Reduce ambient temperature if possible
	Deficient cooling	Improve cooling



In the event of further malfunctions, contact ebm-papst.

#### 5.1 Cleaning

##### NOTE

##### Damage to the device during cleaning

Malfunction possible

- Do not clean the device using a water jet or high-pressure cleaner.
- Do not use any acid, alkali or solvent-based cleaning agents.
- Do not use any pointed or sharp-edged objects for cleaning

#### 5.2 Safety inspection

What to check	How to check	How often	What action?
Device for damage	Visual inspection	At least every 6 months	Replace device
Fastening the cables	Visual inspection	At least every 6 months	Fasten
Fastening the protective earth terminal	Visual inspection	At least every 6 months	Fasten
Insulation of cables for damage	Visual inspection	At least every 6 months	Replace cables
Abnormal bearing noise	acoustic	At least every 6 months	Replace device

#### 5.3 Disposal

For ebm-papst, environmental protection and resource preservation are top priority corporate goals.

ebm-papst operates an environmental management system which is certified in accordance with ISO 14001 and rigorously implemented around the world on the basis of German standards.

Right from the development stage, ecological design, technical safety and health protection are fixed criteria.

The following section contains recommendations for ecological disposal of the product and its components.



### 5.3.1 Country-specific legal requirements



#### NOTE

##### Country-specific legal requirements

Always observe the applicable country-specific legal regulations with regard to the disposal of products or waste occurring in the various phases of the life cycle. The corresponding disposal standards are also to be heeded.

### 5.3.2 Disassembly

Disassembly of the product must be performed or supervised by qualified personnel with the appropriate technical knowledge. The product is to be disassembled into suitable components for disposal employing standard procedures for motors.



#### WARNING

**Heavy parts of the product may drop off. Some of the product components are heavy. These components could drop off during disassembly.**

This can result in fatal or serious injury and material damage.

→ Secure components before unfastening to stop them falling.

### 5.3.3 Component disposal

The products are mostly made of steel, copper, aluminum and plastic. Metallic materials are generally considered to be fully recyclable. Separate the components for recycling into the following categories:

- Steel and iron
- Aluminum
- Non-ferrous metal, e.g. motor windings
- Plastics, particularly with brominated flame retardants, in accordance with marking
- Insulating materials
- Cables and wires
- Electronic scrap, e.g. circuit boards

Only ferrite magnets and not rare earth magnets are used in external rotor motors from ebm-papst Mulfingen GmbH & Co. KG.

⇒ Ferrite magnets can be disposed of in the same way as normal iron and steel.

Electrical insulating materials on the product, in cables and wires are made of similar materials and are therefore to be treated in the same manner.

The materials concerned are as follows:

- Miscellaneous insulators used in the terminal box
- Power cables
- Cables for internal wiring
- Electrolytic capacitors

Dispose of electronic components employing the proper procedures for electronic scrap.



→ Please contact ebm-papst for any other questions on disposal.