

**ASIA PACIFIC SHENGRUI LIMITED**

Phone +00852 56261528

info@apacfan.com

www.apacfan.com

**Nominal data**

<b>Type</b>	<b>M4Q045-CF07-04</b>		
<b>Motor</b>	<b>M4Q045-CF</b>		
Phase		1~	1~
Nominal voltage	VAC	115	115
Frequency	Hz	50	60
Type of data definition		me	me
Valid for approval / standard		CE	CE
Speed	min <sup>-1</sup>	1300	1550
Power input	W	60	58
Power output	W	16	16
Current draw	A	0.8	0.74
Max. ambient temperature	°C	40	40
Starting current	A	1.1	1.0

ml = max. load · me = max. efficiency · fa = running at free air · cs = customer specs · cu = customer unit  
Subject to alterations



### Technical features

<b>Mass</b>	1.3 kg
<b>Size</b>	45 mm
<b>Material of end shield</b>	Die-cast aluminium
<b>Direction of rotation</b>	Counter-clockwise, seen on rotor
<b>Type of protection</b>	IP 42; Depending on installation and position
<b>Insulation class</b>	"B"
<b>Max. permissible ambient motor temp. (transp./ storage)</b>	+ 80 °C
<b>Min. permissible ambient motor temp. (transp./storage)</b>	- 40 °C
<b>Mounting position</b>	Shaft horizontal
<b>Condensate discharge holes</b>	None
<b>Operation mode</b>	S1
<b>Motor bearing</b>	Calotte bearing
<b>Touch current acc. IEC 60990 (measuring network Fig. 4, TN system)</b>	< 0.75 mA
<b>Motor protection</b>	Thermal overload protector (TOP) wired internally
<b>Cable exit</b>	Lateral
<b>Protection class</b>	I (if protective earth is connected by customer)
<b>Product conforming to standard</b>	EN 60335-1; CE
<b>Approval</b>	UL 2111; CSA C22.2 Nr.77

## Product drawing

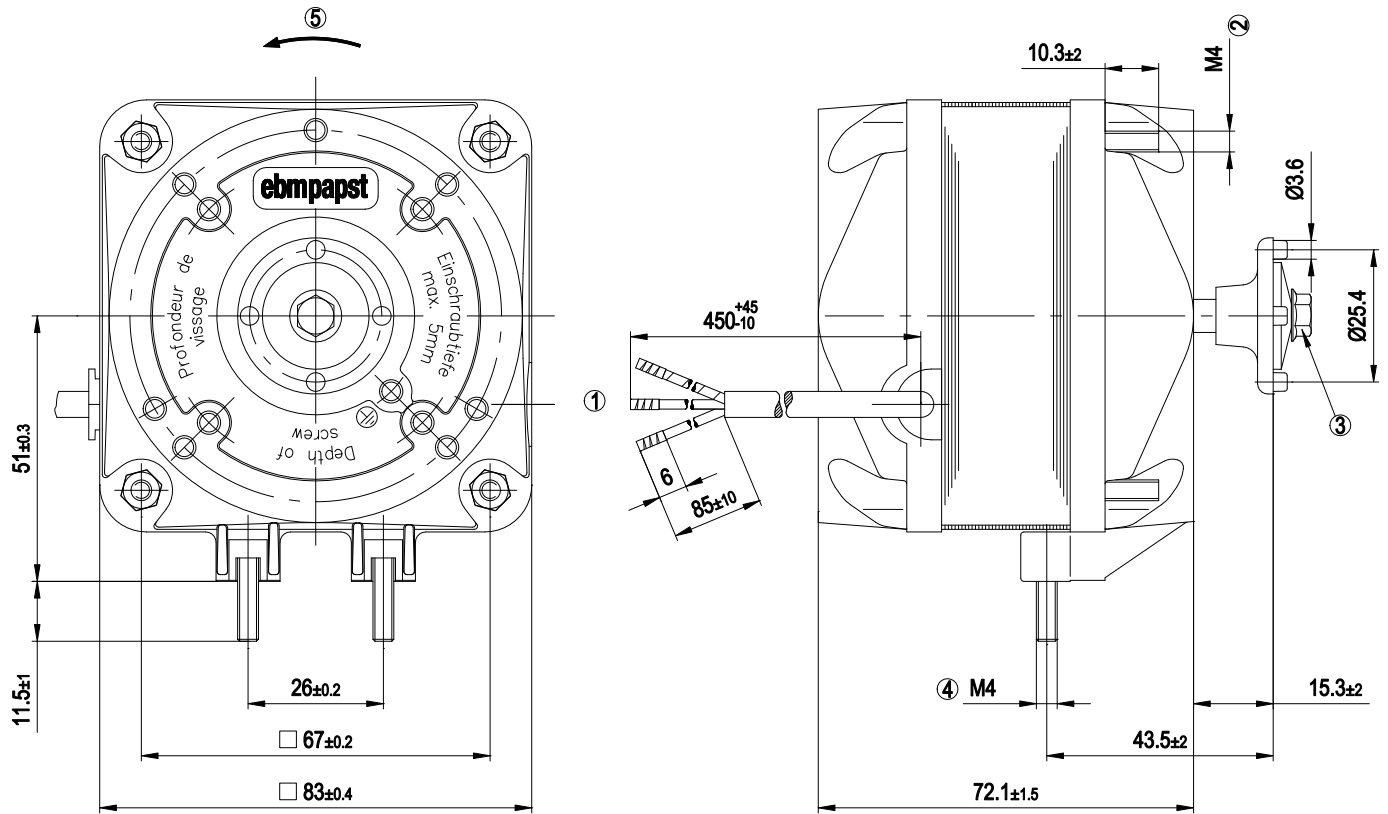

1	Connection line PVC 3 x 0.5 mm <sup>2</sup> ; 3 x brass lead tips crimped
2	Nut tightening torque, for fastening the wall ring or guard grille: 2.3 Nm
3	Screw tightening torque, for fastening the impeller: 1.4 Nm
4	Nut tightening torque, for fastening the mounting bracket: 2.3 Nm
5	Direction of rotation counter-clockwise, seen on shaft end

## Connection screen

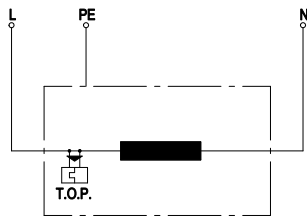

L	= blue
PE	= green / yellow
N	= brown
TOP	= Thermal overload protector

## Charts: Speed

