

ASIA PACIFIC SHENGRUI LIMITED

Phone +00852 56261528

info@apacfan.com

www.apacfan.com

Nominal data

Type	M4Q045-CF01-01		
Motor	M4Q045-CF		
Phase		1~	1~
Nominal voltage	VAC	230	230
Frequency	Hz	50	60
Type of data definition		me	me
Valid for approval / standard		CE	CE
Speed	min ⁻¹	1300	1550
Power input	W	60	58
Power output	W	16	16
Current draw	A	0.42	0.36
Min. ambient temperature	°C	-30	-30
Max. ambient temperature	°C	40	40
Starting current	A	0.58	0.5

ml = Max. load · me = Max. efficiency · fa = Running at free air · cs = Customer specs · cu = Customer unit
 Subject to alterations



Technical features

Mass	1.3 kg
Size	45 mm
Material of end shield	Die-cast aluminium
Direction of rotation	Counter-clockwise, seen on rotor
Type of protection	IP 42; Depending on installation and position
Insulation class	"B"
Max. permissible ambient motor temp. (transp./ storage)	+ 80 °C
Min. permissible ambient motor temp. (transp./storage)	- 40 °C
Mounting position	Any
Condensate discharge holes	None
Operation mode	S1
Motor bearing	Calotte bearing
Touch current acc. IEC 60990 (measuring network Fig. 4, TN system)	< 0.75 mA
Motor protection	Thermal overload protector (TOP) wired internally
Cable exit	Lateral
Protection class	I (if protective earth is connected by customer)
Product conforming to standard	EN 60335-1; CE
Approval	EAC; VDE

Product drawing

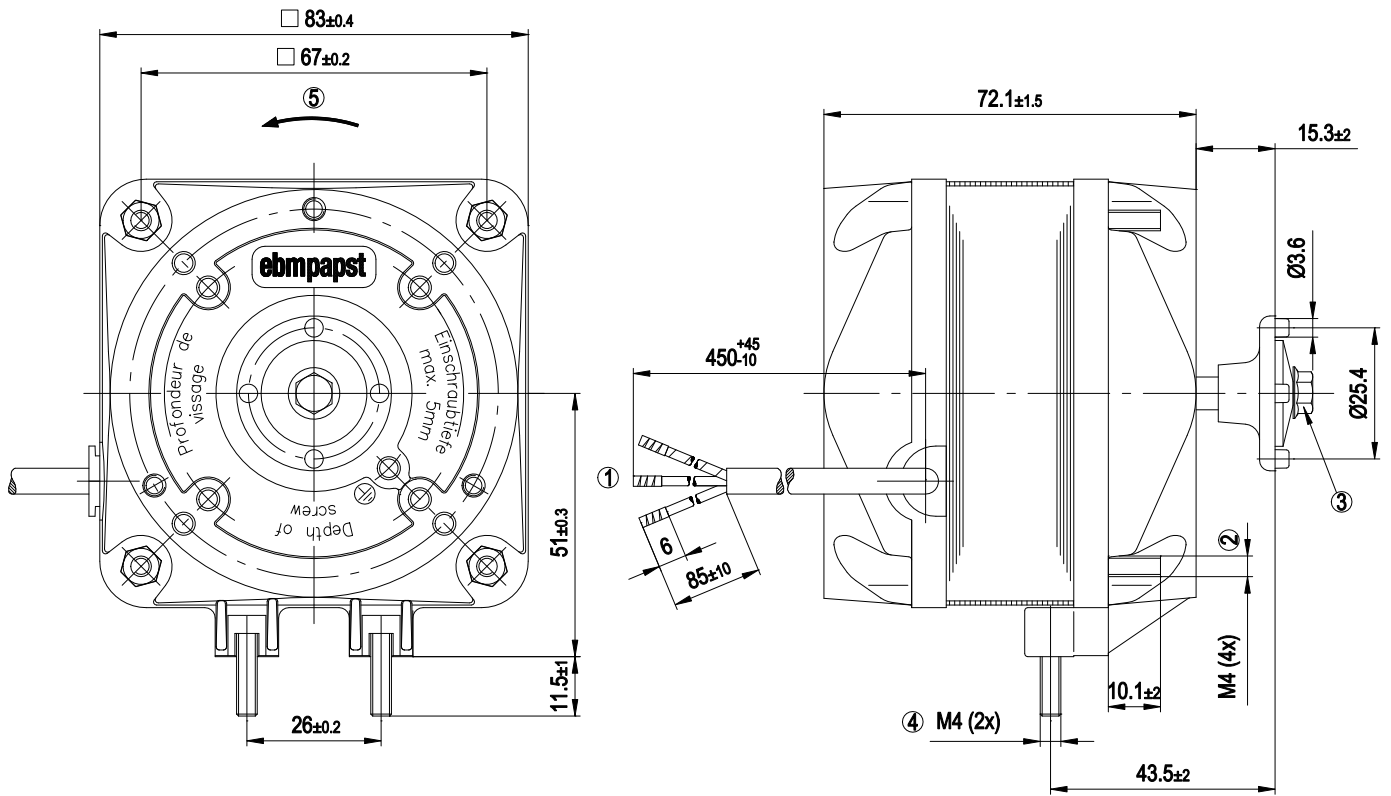

- | | |
|---|----------------------------------------------------------------------------|
| 1 | Connection line PVC 0.5 mm ² , 3x brass lead tips crimped |
| 2 | Nut tightening torque, for fastening the wall ring or guard grille: 2,3 Nm |
| 3 | Screw tightening torque, for fastening the impeller: 1,4 Nm |
| 4 | Nut tightening torque, for fastening the mounting bracket: 2,3 Nm |
| 5 | Direction of rotation counter-clockwise, seen on shaft end |

Connection screen

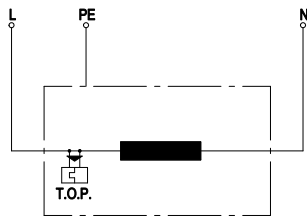

L	= blue
PE	= green / yellow
N	= brown
TOP	= Thermal overload protector

Charts: Speed

