

## ASIA PACIFIC SHENGRUI LIMITED

Phone +00852 56261528

info@apacfan.com

www.apacfan.com

## Nominal data

Type	K3G560-PB31-03	
Motor	M3G150-IF	
Phase		3~
Nominal voltage	VAC	400
Nominal voltage range	VAC	380 .. 480
Frequency	Hz	50/60
Method of obtaining data		ml
Status		prelim.
Speed (rpm)	min <sup>-1</sup>	1700
Power consumption	W	4400
Current draw	A	6.6
Min. ambient temperature	°C	-25
Max. ambient temperature	°C	40

ml = Max. load · me = Max. efficiency · fa = Free air · cs = Customer specification · ce = Customer equipment  
Subject to change

## Data according to Commission Regulation (EU) 327/2011

		Actual	Req. 2015			
01 Overall efficiency $\eta_{es}$	%	69.9	58.1	09 Power consumption $P_{ed}$	kW	4.25
02 Measurement category		A		09 Air flow $q_v$	m <sup>3</sup> /h	9825
03 Efficiency category		Static		09 Pressure increase $p_{fs}$	Pa	1049
04 Efficiency grade N		73.8	62	10 Speed (rpm) n	min <sup>-1</sup>	1700
05 Variable speed drive		Yes		11 Specific ratio*		1.01

Data obtained at optimum efficiency level.

The ErP data is determined using a motor-impeller combination in a standardized measurement setup.

\* Specific ratio =  $1 + p_{fs} / 100\,000\text{ Pa}$

LU-183216



## Technical description

<b>Weight</b>	53.3 kg
<b>Fan size</b>	560 mm
<b>Rotor surface</b>	Painted black
<b>Electronics housing material</b>	Die-cast aluminum
<b>Impeller material</b>	Sheet aluminum
<b>Support plate material</b>	Sheet steel, galvanized
<b>Support bracket material</b>	Steel, painted black
<b>Inlet nozzle material</b>	Sheet steel, galvanized
<b>Number of blades</b>	5
<b>Direction of rotation</b>	Clockwise, viewed toward rotor
<b>Degree of protection</b>	IP55
<b>Insulation class</b>	"F"
<b>Moisture (F) / Environmental (H) protection class</b>	H1
<b>Ambient temperature note</b>	Occasional start-up between -40°C and -25°C is permissible. For continuous operation at temperatures below -25°C (e.g. refrigeration applications) we recommend our fan design with special low-temperature bearings.
<b>Max. permitted ambient temp. for motor (transport/storage)</b>	+80 °C
<b>Min. permitted ambient temp. for motor (transport/storage)</b>	-40 °C
<b>Installation position</b>	See product drawing
<b>Condensation drainage holes</b>	On rotor side
<b>Mode</b>	S1
<b>Motor bearing</b>	Ball bearing
<b>Technical features</b>	<ul style="list-style-type: none"> <li>- Operation and alarm display with LED</li> <li>- External 15-50 VDC input (parameterization)</li> <li>- Alarm relay</li> <li>- Integrated PI controller</li> <li>- Configurable inputs/outputs (I/O)</li> <li>- MODBUS V6</li> <li>- Motor current limitation</li> <li>- RFID - ISO 15693 compatible</li> <li>- RS-485 MODBUS-RTU</li> <li>- Soft start</li> <li>- EEPROM write cycles: 100,000 maximum</li> <li>- Voltage output 3.3-24 VDC, Pmax = 800 mW</li> <li>- Control interface with SELV potential safely disconnected from the mains</li> <li>- Thermal overload protection for electronics/motor</li> <li>- Line undervoltage / phase failure detection</li> </ul>
<b>Touch current according to IEC 60990 (measuring circuit Fig. 4, TN system)</b>	<= 3.5 mA
<b>Electrical hookup</b>	Via terminal box
<b>Motor protection</b>	Reverse polarity and locked-rotor protection
<b>Protection class</b>	I (with customer connection of protective earth)
<b>Conformity with standards</b>	EN 61800-5-1; CE
<b>Approval</b>	EAC

# EC centrifugal module - RadiPac

backward-curved, single-intake

with support bracket

## Product drawing

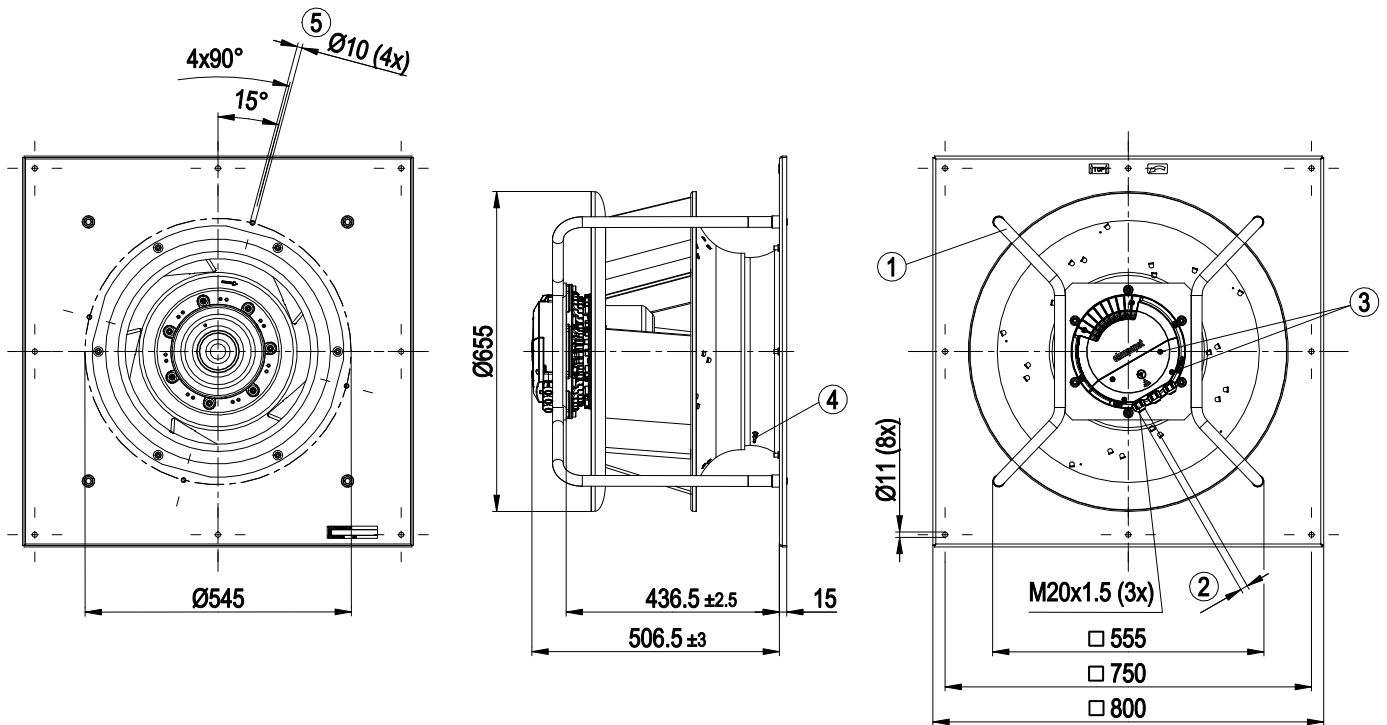

1	Installed position: shaft horizontal (install support struts only vertically as illustrated) or rotor on bottom; rotor on top on request
2	Cable diameter min. 4 mm, max. 10 mm, tightening torque $2 \pm 0.3$ Nm
3	Tightening torque $1.5 \pm 0.2$ Nm
4	Inlet ring with pressure tap (k-factor: 348)
5	Mounting holes for FlowGrid

# EC centrifugal module - RadiPac

backward-curved, single-intake  
with support bracket

## Connection diagram

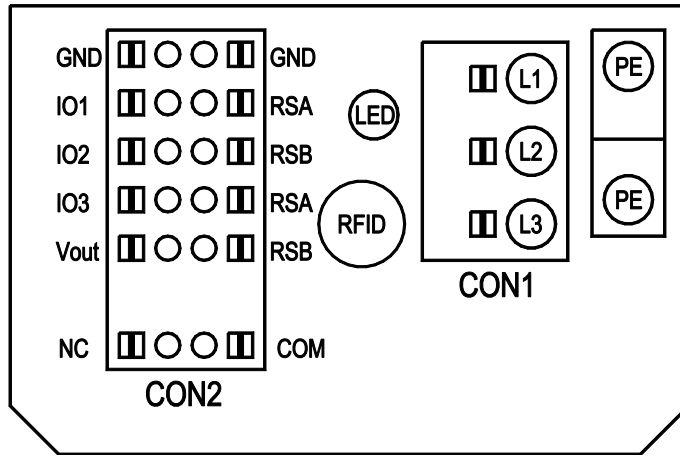

No.	Conn.	Designation	Function/assignment
CON1	-	L1, L2, L3	Supply connection, power supply, protection class 1
PE	-	PE	Ground connection, PE connection
CON2	-	RSA	Bus connection RS485, RSA, MODBUS-RTU; SELV
CON2	-	RSB	Bus connection RS485, RSB, MODBUS-RTU; SELV
CON2	-	GND	GND reference ground for control interface, SELV
CON2	-	IO1	IN2: Digital input - positive logic (factory setting: Enable) function parameterizable, SELV - normal: Pin open or applied voltage < 1.5 VDC - inverse: applied voltage 3.5-50 VDC
CON2	-	IO2	IN1: Analog input 0-10 V 0-10 V, Ri=100 K, parameterizable as set value or measured value (factory setting: set value) characteristic curve parameterizable, SELV
CON2	-	IO3	OUT1: Analog output 0-10 V 0-10 V, max 5 mA, function parameterizable (factory setting: modulation level) max output frequency 300 Hz, SELV
CON2	-	V out	Voltage output 3.3-24 VDC +/-5%, Pmax=800 mW, voltage parameterizable (factory setting: 10 VDC) short-circuit-proof, supply for external devices, SELV alternatively: 15-50 VDC input for parameterization via Modbus without line voltage
CON2	-	COM	Status relay, floating status contact; common connection, nominal voltage 250 VAC; max 2 A (AC1): min 10 mA; Reinforced insulation in accordance with EN60335-1, EN61800-5-1, UL60730-1
CON2	-	NC	Status relay, floating status contact, break for failure



## Curves: Air performance 50 Hz

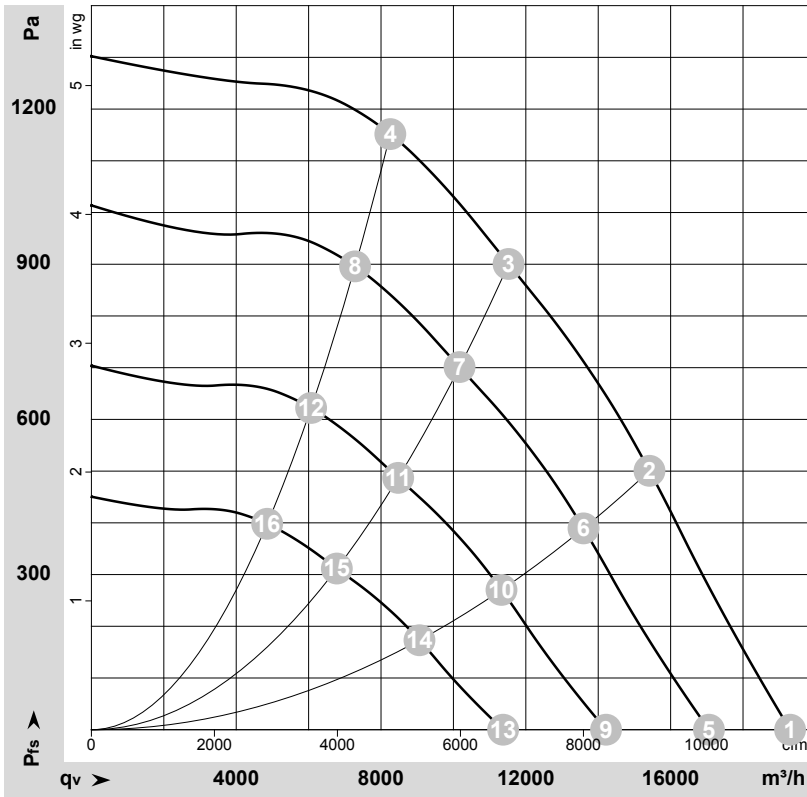

$\rho = 1.15 \text{ kg/m}^3 \pm 2 \%$

Measurement: LU-183216-1

Air performance measured according to ISO 5801 installation category A. For detailed information on the measurement setup, contact ebmpapst. Intake sound level: Sound power level according to ISO 13347 / sound pressure level measured at 1 m distance from fan axis. The values given are valid under the specified measuring conditions and may vary due to conditions of installation. For deviations from the standard configuration, the parameters have to be checked on the installed unit.

## Measured values

	U	f	n	P <sub>ed</sub>	I	LpA <sub>in</sub>	LwA <sub>in</sub>	LwA <sub>out</sub>	q <sub>v</sub>	P <sub>fs</sub>	q <sub>v</sub>	P <sub>fs</sub>
	V	Hz	min <sup>-1</sup>	W	A	dB(A)	dB(A)	dB(A)	m <sup>3</sup> /h	Pa	cfm	in. wg
1	400	50	1700	2717	4.17	94	102	100	19300	0	11360	0.00
2	400	50	1700	3739	5.69	85	91	91	15415	500	9075	2.01
3	400	50	1700	4400	6.60	75	83	87	11525	900	6785	3.61
4	400	50	1700	4238	6.47	79	87	89	8255	1150	4860	4.62
5	400	50	1500	1876	2.88	91	99	97	17060	0	10040	0.00
6	400	50	1500	2563	3.90	82	88	88	13595	393	8000	1.58
7	400	50	1500	3012	4.57	72	80	84	10170	701	5985	2.81
8	400	50	1500	2908	4.44	76	83	86	7285	899	4285	3.61
9	400	50	1250	1086	1.67	86	95	93	14215	0	8365	0.00
10	400	50	1250	1483	2.26	77	84	83	11330	273	6665	1.10
11	400	50	1250	1743	2.65	68	75	79	8475	487	4990	1.96
12	400	50	1250	1683	2.57	71	79	82	6070	624	3570	2.51
13	400	50	1000	556	0.85	81	89	87	11375	0	6695	0.00
14	400	50	1000	759	1.16	72	78	78	9060	175	5335	0.70
15	400	50	1000	892	1.35	62	69	73	6780	312	3990	1.25
16	400	50	1000	862	1.32	66	73	76	4855	400	2860	1.61

U = Power supply · f = Frequency · n = Speed (rpm) · P<sub>ed</sub> = Power consumption · I = Current draw · LpA<sub>in</sub> = Sound pressure level intake side · LwA<sub>in</sub> = Sound power level intake side  
LwA<sub>out</sub> = Sound power level outlet side · q<sub>v</sub> = Air flow · P<sub>fs</sub> = Pressure increase

