

K3G560-8317080796
8317080796

EC centrifugal module - RadiCal

backward-curved, single-intake
with support bracket

ASIA PACIFIC SHENGRUI LIMITED

Phone +00852 56261528
info@apacfan.com
www.apacfan.com

Nominal data

Type	K3G560-8317080796	
Motor	M3G150-FF	
Phase		3~
Nominal voltage	VAC	400
Nominal voltage range	VAC	380 .. 480
Frequency	Hz	50/60
Method of obtaining data		ml
Status		prelim.
Speed (rpm)	min ⁻¹	1780
Power consumption	W	3350
Current draw	A	5.1
Min. ambient temperature	°C	-40
Max. ambient temperature	°C	50

ml = Max. load · me = Max. efficiency · fa = Free air · cs = Customer specification · ce = Customer equipment
Subject to change



K3G560-8317080796
8317080796

EC centrifugal module - RadiCal

backward-curved, single-intake
with support bracket

Technical description

Size	560 mm
Motor size	150
Rotor surface	Painted black
Electronics housing material	Die-cast aluminum
Impeller material	PP plastic
Support plate material	Sheet steel, galvanized
Support bracket material	Steel, painted black
Inlet nozzle material	Sheet steel, galvanized
Number of blades	6
Direction of rotation	Clockwise, viewed toward rotor
Degree of protection	IP55
Insulation class	"F"
Moisture (F) / Environmental (H) protection class	H1
Ambient temperature note	Occasional start-up at temperatures between -40°C and -25°C is permitted. For continuous operation at ambient temperatures below -25°C (such as refrigeration applications), use must be made of a fan design with special low-temperature bearings.
Max. permitted ambient temp. for motor (transport/storage)	+80 °C
Min. permitted ambient temp. for motor (transport/storage)	-40 °C
Installation position	See legend on product drawing
Condensation drainage holes	On rotor side
Mode	S1
Motor bearing	Ball bearing
Technical features	<ul style="list-style-type: none">- Operation and alarm display with LED- External 15-50 VDC input (parameterization)- Alarm relay- Integrated PI controller- Configurable inputs/outputs (I/O)- MODBUS V6.0- Motor current limitation- RFID - ISO 15693 compatible- RS-485 MODBUS-RTU- Soft start- Voltage output 3.3-24 VDC, Pmax = 800 mW- Control interface with SELV potential safely disconnected from the mains- Thermal overload protection for electronics/motor- Line undervoltage / phase failure detection
EMC immunity to interference	According to EN 61000-6-2 (industrial environment)
EMC interference emission	According to EN 61000-6-3 (household environment), except EN 61000-3-2 for professionally used equipment with a total rated power greater than 1 kW
Touch current according to IEC 60990 (measuring circuit Fig. 4, TN system)	<= 3.5 mA
Electrical hookup	Terminal box
Protection class	I (with customer connection of protective earth)
Conformity with standards	EN 61800-5-1; CE
Approval	EAC ; CSA C22.2 No. 77 + CAN/CSA-E60730-1; UL 1004-7 + 60730-1



K3G560-8317080796
8317080796

EC centrifugal module - RadiCal

backward-curved, single-intake
with support bracket

Product drawing

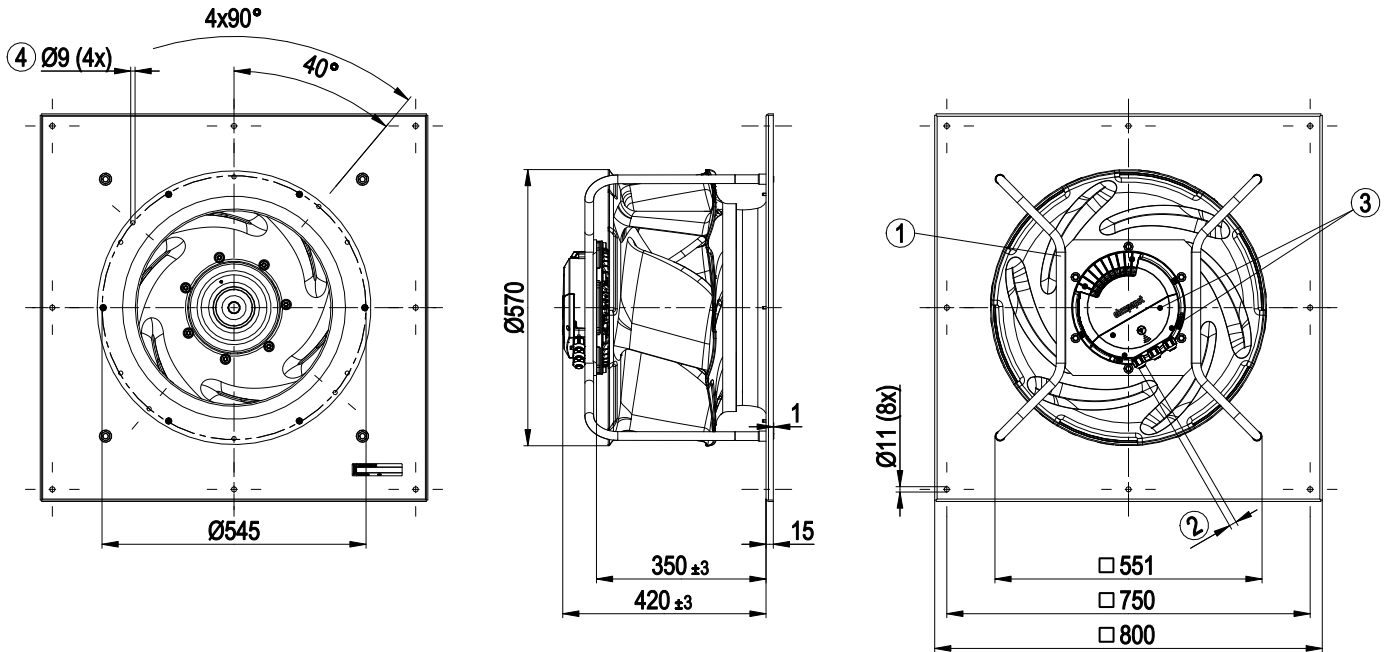

1	Installed position: shaft horizontal (install support struts only vertically as illustrated) or rotor on bottom; rotor on top on request
2	Cable diameter min. 4 mm, max. 10 mm, tightening torque 4 ± 0.6 Nm
3	Tightening torque 1.5 ± 0.2 Nm
4	Attachment holes for FlowGrid (00630-2-2957 not included in scope of delivery)

EC centrifugal module - RadiCal

backward-curved, single-intake
with support bracket

Connection diagram

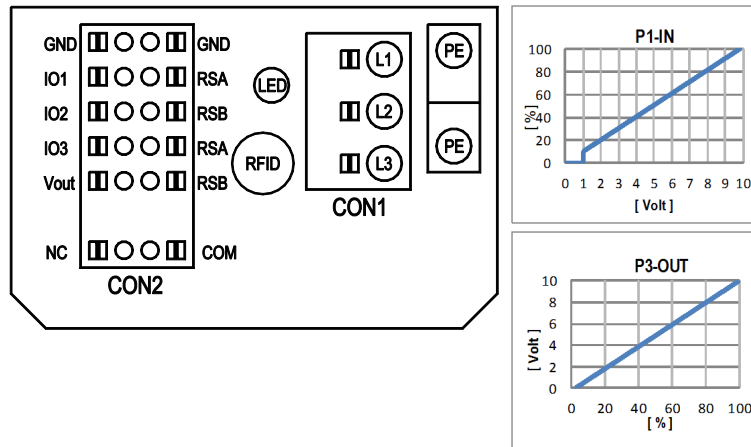

No.	Conn.	Designation	Function/assignment
	CON1	L1, L2, L3	Power supply, phase, see nameplate for voltage range
	PE	PE	Protective earth
	CON2	RSA	RS485 interface for MODBUS, RSA; SELV
	CON2	RSB	RS485 interface for MODBUS, RSB; SELV
	CON2	GND	Reference ground for control interface, SELV
	CON2	IO1	Function parameterizable (see "Optional interface functions" table) Factory setting: Digital input - high active, function: Disable input, SELV - inactive: Pin open or applied voltage < 1.5 VDC - active: applied voltage 3.5-50 VDC Reset function: Triggering of error reset on change of state from "enabled" to "disabled"
	CON2	IO2	Function parameterizable (see "Optional interface functions" table) Factory setting: Analog input 0-10 V / PWM, Ri=100 kΩ, function: Set value Characteristic curve parameterizable (see input characteristic curve P1-IN), SELV
	CON2	IO3	Function parameterizable (see "Optional interface functions" table) Factory setting: Analog output 0-10 V, max. 5 mA, function: Fan modulation level Characteristic curve parameterizable (see output characteristic curve P3-OUT), SELV
	CON2	Vout	Voltage output 3.3-24 VDC ±5%, Pmax=800 mW, voltage parameterizable Factory setting: 10 VDC short-circuit-proof, supply for external devices, SELV alternatively: 15-50 VDC input for parameterization via MODBUS without line voltage
	CON2	COM	Status relay, floating status contact, common connection, contact rating 250 VAC / 2 A (AC1) / min. 10 mA, reinforced insulation on supply side and on control interface side
	CON2	NC	Status relay, floating status contact, break for failure
		LED	green: status = good, ready for operation orange: status = warning red: status = failure
		P1-IN	Input characteristic curve
		P3-OUT	Output characteristic curve

Terminal/plug assignment

	configurable IO functions: normal / inverse	MODBUS Register for IO mode configuration	electrical specification	configurable IO mode
CON2	<ul style="list-style-type: none"> configurable option 	D158 [0]	<p>active: applied voltage 3.5-50VDC, SELV $R_i=100k$, characteristic curve parameterizable, $f_{PWM}=1k..10kHz$, SELV $U_{max}=50VDC$, $I_{max}=20mA$, SELV</p> <p>not active: pin open or applied voltage < 1.5VDC</p> <p>active: applied voltage 3.5-50VDC, SELV $R_i=100k$, characteristic curve parameterizable, $f_{PWM}=1k..10kHz$, SELV $R_i=125R$, characteristic curve parameterizable, SELV</p> <p>not active: pin open or applied voltage < 1.5VDC</p> <p>active: applied voltage 3.5-50VDC, SELV</p> <p>not active: applied voltage < 1.5VDC, SELV 40Hz - 10kHz, characteristics parameterizable</p> <p>not active: pin open or applied voltage 3.5-50VDC active: applied voltage < 1.5VDC, SELV function parameterizable, max. 5mA, max output frequency 300Hz, SELV 0-10V max. 5mA, max output frequency 300Hz, SELV 0-10V max. 5mA, max output frequency 300Hz, SELV</p> <p>MODBUS RTU, specification V6.0, SELV</p>	<ul style="list-style-type: none"> AIN1 0-10V/PWM: analog input PWMIn3: digital input
Vout	<p>alternatively: input auxiliary power supply for parameterization via RS485/MODBUS RTU without line voltage</p>			

Curves: Air performance 50 Hz

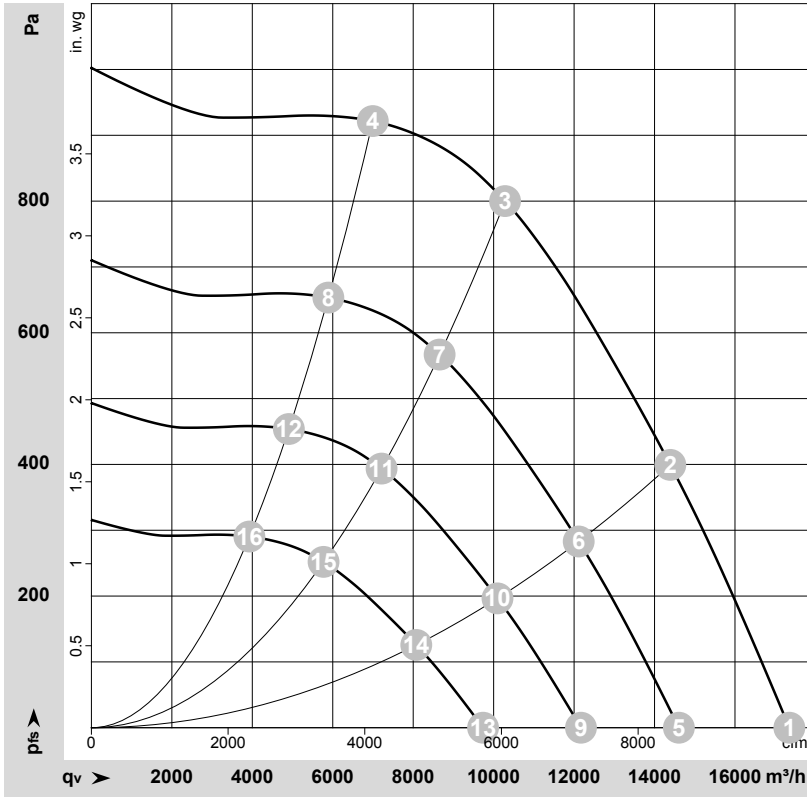

$\rho = 1.15 \text{ kg/m}^3 \pm 2 \%$

Measurement: 13283

Air performance measured according to ISO 5801 installation category A. For detailed information on the measurement setup, contact ebm-papst. Intake sound level: Sound power level according to ISO 13347 / sound pressure level measured at 1 m distance from fan axis. The values given are valid under the specified measuring conditions and may vary due to conditions of installation. For deviations from the standard configuration, the parameters have to be checked on the installed unit.

Fan performance

	Wired	U	f	n	P _{ed}	I	LpA _{in}	LwA _{in}	LwA _{out}	q _v	p _{fs}	q _v	p _{fs}
		V	Hz	min ⁻¹	W	A	dB(A)	dB(A)	dB(A)	m ³ /h	Pa	cfm	in. wg
1	3~	400	50	1780	1835	2.89	87	92	96	17350	0	10210	0.00
2	3~	400	50	1780	2817	4.33	79	86	91	14390	400	8470	1.61
3	3~	400	50	1780	3350	5.10	71	78	84	10285	800	6055	3.21
4	3~	400	50	1780	3094	4.75	78	85	89	6995	920	4120	3.69
5	3~	400	50	1500	1094	1.72	82	88	92	14605	0	8595	0.00
6	3~	400	50	1500	1680	2.59	75	82	86	12115	286	7130	1.15
7	3~	400	50	1500	1984	3.04	66	74	80	8655	569	5095	2.28
8	3~	400	50	1500	1847	2.83	74	80	85	5890	654	3465	2.63
9	3~	400	50	1250	633	1.00	78	83	87	12170	0	7165	0.00
10	3~	400	50	1250	972	1.50	70	77	82	10095	199	5940	0.80
11	3~	400	50	1250	1148	1.76	62	69	76	7215	395	4245	1.59
12	3~	400	50	1250	1069	1.64	69	76	80	4910	454	2890	1.82
13	3~	400	50	1000	324	0.51	72	77	82	9735	0	5730	0.00
14	3~	400	50	1000	498	0.77	64	71	76	8075	127	4755	0.51
15	3~	400	50	1000	588	0.90	56	63	70	5770	253	3395	1.02
16	3~	400	50	1000	547	0.84	63	70	74	3925	291	2310	1.17

Wired = Wiring · U = Voltage · f = Frequency · n = Speed (rpm) · P_{ed} = Power consumption · I = Current draw · LpA_{in} = Sound pressure level intake side · LwA_{in} = Sound power level intake side
LwA_{out} = Sound power level outlet side · q_v = Air flow · p_{fs} = Pressure increase