

K3G190-RD45-03

EC centrifugal module - RadiCal

backward-curved, single-intake

with housing



ebm-papst Mulfingen GmbH & Co. KG

ASIA PACIFIC SHENGRUI
LIMITED
Phone +00852 56261528
info@apacfan.com
www.apacfan.com

Limited partnership · Headquarters Mulfingen
Amtsgericht (court of registration) Stuttgart · HRA 590344

General partner Elektrobau Mulfingen GmbH · Headquarters Mulfingen
Amtsgericht (court of registration) Stuttgart · HRB 590142

Nominal data

Type	K3G190-RD45-03	
Motor	M3G055-CF	
Phase		1~
Nominal voltage	VAC	230
Nominal voltage range	VAC	200 .. 240
Frequency	Hz	50/60
Method of obtaining data		ml
Speed (rpm)	min ⁻¹	4120
Power consumption	W	169
Current draw	A	1.35
Min. ambient temperature	°C	-25
Max. ambient temperature	°C	60

ml = Max. load · me = Max. efficiency · fa = Free air · cs = Customer specification · ce = Customer equipment
Subject to change

Data according to ErP Directive

		Actual	Req. 2015
01 Overall efficiency η_{es}	%	56	43.1
02 Measurement category		A	
03 Efficiency category		Static	
04 Efficiency grade N		74.9	62
05 Variable speed drive		Yes	

Data obtained at optimum efficiency level.

The ErP data is determined using a motor-impeller combination in a standardized measurement setup.

09 Power consumption P_{ed}	kW	0.16
09 Air flow q_v	m ³ /h	565
09 Pressure increase p_{fs}	Pa	524
10 Speed (rpm) n	min ⁻¹	4055
11 Specific ratio*		1.01

* Specific ratio = $1 + p_{fs} / 100\,000\text{ Pa}$

LU-132500



ebmpapst

K3G190-RD45-03

EC centrifugal module - RadiCal

backward-curved, single-intake

with housing

Technical description

Weight	1.8 kg
Fan size	190 mm
Rotor surface	Thick-film passivated
Impeller material	PA plastic
Housing material	PA plastic
Number of blades	7
Direction of rotation	Clockwise, viewed toward rotor
Degree of protection	IP54
Insulation class	"B"
Max. permitted ambient temp. for motor (transport/storage)	+ 80 °C
Min. permitted ambient temp. for motor (transport/storage)	- 40 °C
Installation position	Any
Condensation drainage holes	None, open rotor
Mode	S1
Motor bearing	Ball bearing
Technical features	<ul style="list-style-type: none">- Output 10 VDC, max. 10 mA- Tach output- Power limiter- Motor current limitation- Soft start- Control input 0-10 VDC / PWM- Control interface with SELV potential safely disconnected from the mains- Overvoltage detection- Thermal overload protection for electronics/motor- Line undervoltage detection
EMC immunity to interference	According to EN 61000-6-2 (industrial environment)
EMC interference emission	According to EN 61000-6-4 (industrial environment)
Touch current according to IEC 60990 (measuring circuit Fig. 4, TN system)	<= 3.5 mA
Motor protection	Locked-rotor protection
With cable	Variable
Protection class	I (with customer connection of protective earth)
Conformity with standards	EN 60335-1; CE
Approval	CSA C22.2 No. 77; UL 2111; EAC; CCC



K3G190-RD45-03

EC centrifugal module - RadiCal

backward-curved, single-intake
with housing

Product drawing

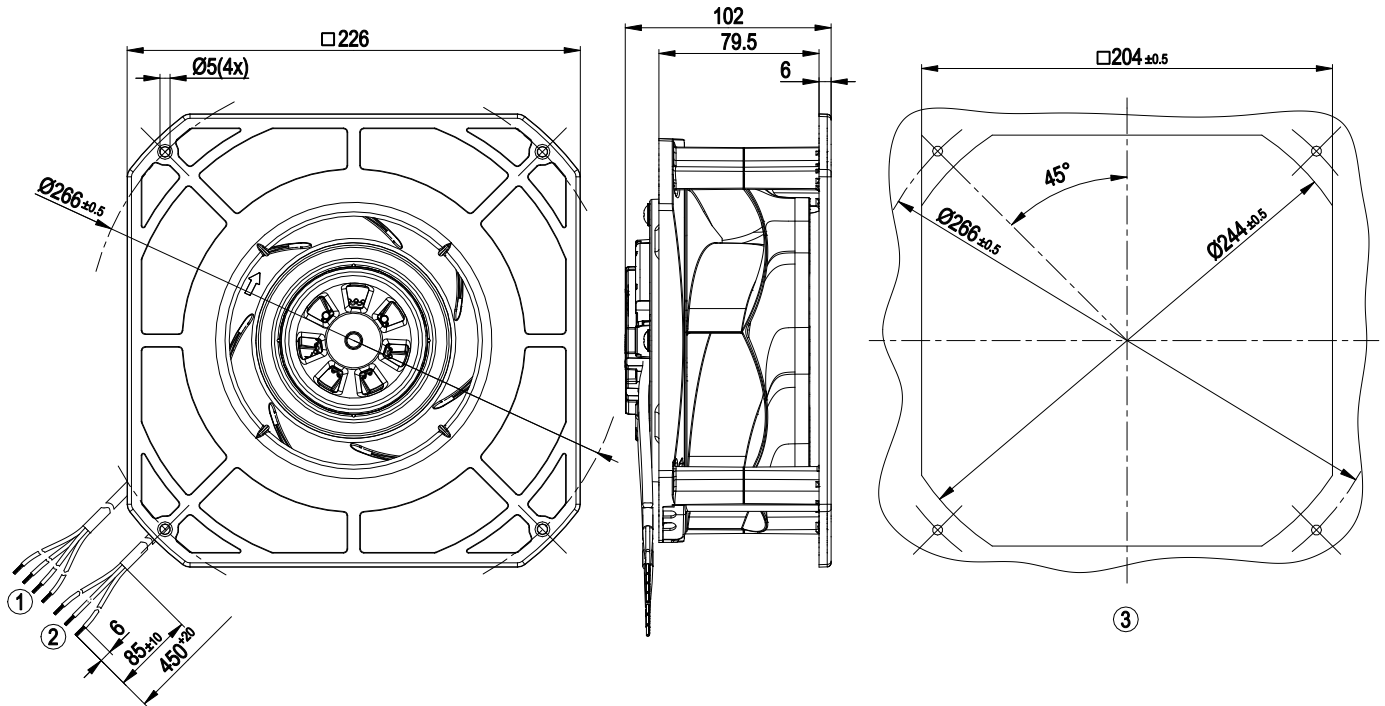

- | | |
|---|--|
| 1 | Cable PVC 3G AWG20, 3x crimped splices |
| 2 | Cable PVC 4x AWG22, 4x crimped splices |
| 3 | Mounting dimensions |



Connection diagram

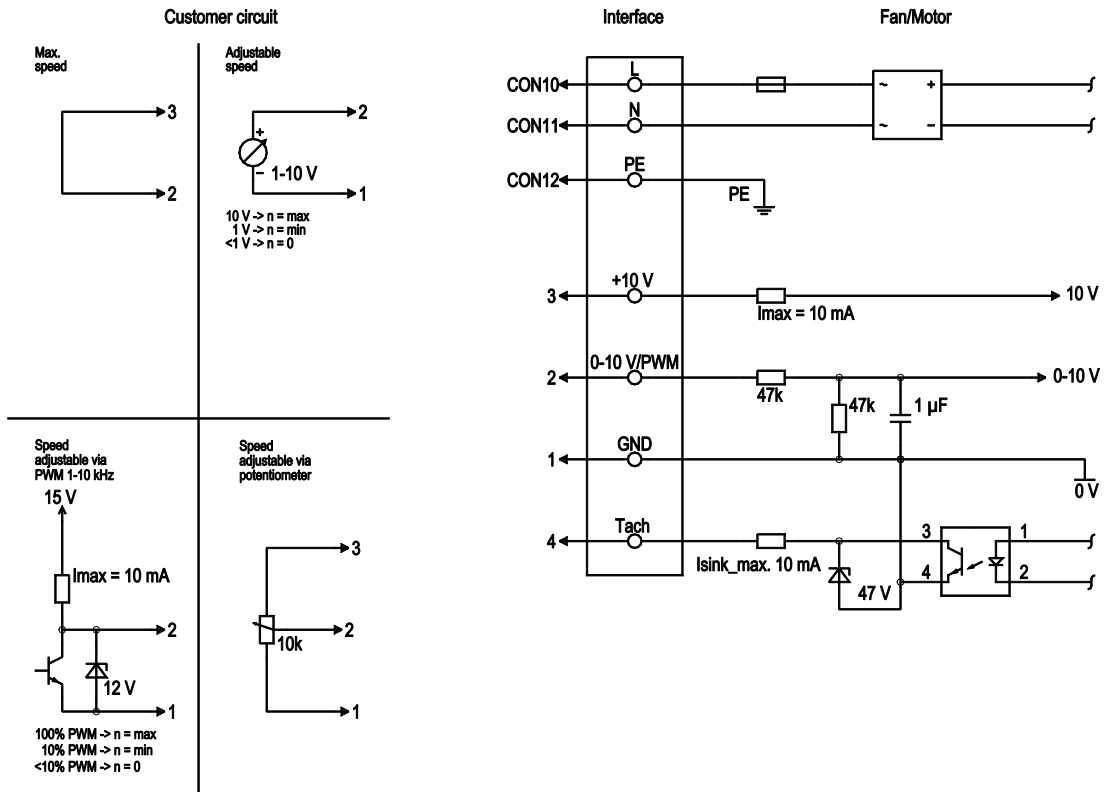

No.	Conn.	Designation	Color	Function/assignment
	CON10	L	black	Supply connection, power supply, phase, see nameplate for voltage range
	CON11	N	blue	Supply connection, power supply, neutral conductor, see nameplate for voltage range
	CON12	PE	green/yellow	Ground connection
	2	0- 10V PWM	yellow	0-10 V / PWM control input, R _i =100 kΩ, SELV
	4	Tach	white	Tach output, open collector, 1 pulse per revolution, I _{sink max} = 10 mA, SELV
	3	+10 V	red	Fixed voltage output 10 VDC +/-3 %, I _{max} . 10 mA, short-circuit-proof, power supply for ext. devices (e.g. pot), SELV
	1	GND	blue	Reference ground for control interface, SELV

Curves: Air performance 50 Hz

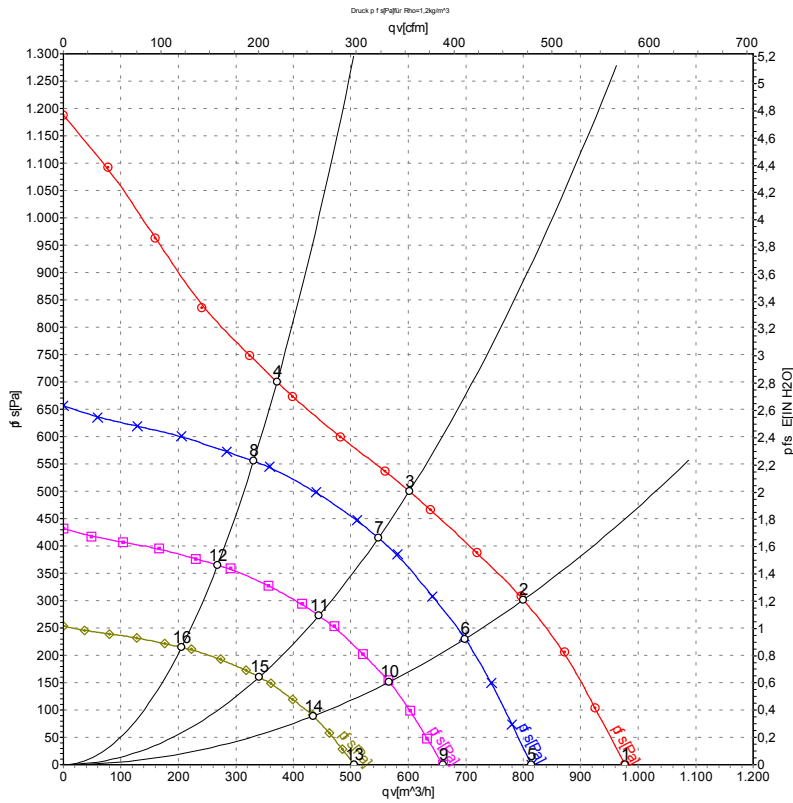

Measurement: LU-132500-1

Air performance measured according to ISO 5801 installation category A. For detailed information on the measurement setup, contact ebmpapst. Intake sound level: Sound power level according to ISO 13347 / sound pressure level measured at 1 m distance from fan axis. The values given are valid under the specified measuring conditions and may vary due to conditions of installation. For deviations from the standard configuration, the parameters have to be checked on the installed unit.

Measured values

	U	f	n	P _{ed}	I	LpA _{in}	LwA _{in}	q _v	P _{fs}	q _v	P _{fs}
	V	Hz	min ⁻¹	W	A	dB(A)	dB(A)	m ³ /h	Pa	cfm	inH2O
1	230	50	4440	161	1.35	72	81	975	0	575	0.00
2	230	50	4235	165	1.35	67	75	800	300	470	1.20
3	230	50	4120	169	1.35	63	72	600	500	355	2.01
4	230	50	4150	160	1.35	66	74	370	700	220	2.81
5	230	50	3700	93	0.81	69	77	815	0	480	0.00
6	230	50	3700	110	0.93	64	72	700	233	410	0.94
7	230	50	3700	125	1.06	61	70	550	415	325	1.67
8	230	50	3700	114	0.97	64	72	330	556	195	2.23
9	230	50	3000	50	0.43	64	73	660	0	390	0.00
10	230	50	3000	59	0.50	59	68	565	153	335	0.61
11	230	50	3000	67	0.57	56	65	445	273	260	1.10
12	230	50	3000	61	0.52	59	67	270	365	160	1.47
13	230	50	2300	22	0.19	58	67	505	0	300	0.00
14	230	50	2300	26	0.22	53	62	435	90	255	0.36
15	230	50	2300	30	0.26	51	59	340	160	200	0.64
16	230	50	2300	27	0.23	54	61	205	215	120	0.86

U = Power supply · f = Frequency · n = Speed (rpm) · P_{ed} = Power consumption · I = Current draw · LpA_{in} = Sound pressure level intake side · LwA_{in} = Sound power level intake side
 q_v = Air flow · P_{fs} = Pressure increase

