

G4D225-GK10-03

AC centrifugal fan

forward curved, single inlet
with housing (large flange)



ASIA PACIFIC SHENGRUI LIMITED

Phone +00852 56261528

info@apacfan.com

www.apacfan.com



Nominal data

Type	G4D225-GK10-03		
Motor	M4D094-FA		
Phase		3~	3~
Nominal voltage	VAC	400	400
Connection		Y	Y
Frequency	Hz	50	60
Type of data definition		fa	ml
Valid for approval / standard		CE	CE
Speed	min ⁻¹	1310	1520
Power input	W	460	515
Current draw	A	0.85	0.9
Min. back pressure	Pa	0	200
Min. ambient temperature	°C	-40	-40
Max. ambient temperature	°C	75	60
Starting current	A	2.8	2.7

ml = Max. load · me = Max. efficiency · fa = Running at free air · cs = Customer specs · cu = Customer unit
Subject to alterations

Data according to ErP directive

Installation category	B
Efficiency category	Total
Variable speed drive	No
Specific ratio*	1.00

* Specific ratio = $1 + p_f / 100\,000\text{ Pa}$

		Actual	Request 2013	Request 2015
Overall efficiency η_e	%	40.3	31.4	38.4
Efficiency grade N		50.9	42	49
Power input P_e	kW	0.21		
Air flow q_v	m ³ /h	910		
Pressure increase p_f	Pa	340		
Speed n	min ⁻¹	1430		

Data definition with optimum efficiency. LU-56990
The ErP data is determined using a motor-impeller combination in a standardised measurement configuration.



AC centrifugal fan

forward curved, single inlet
with housing (large flange)

Technical features

Mass	10.8 kg
Size	225 mm
Surface of rotor	Coated in black
Material of impeller	Sheet steel, hot-galvanised
Housing material	Sheet steel, hot-galvanised
Direction of rotation	Clockwise, seen on rotor
Type of protection	IP 54
Insulation class	"F"
Humidity class	F4-1
Max. permissible ambient motor temp. (transp./ storage)	+ 80 °C
Min. permissible ambient motor temp. (transp./storage)	- 40 °C
Mounting position	Shaft horizontal or rotor on bottom; rotor on top on request
Condensate discharge holes	None
Operation mode	S1
Motor bearing	Ball bearing
Touch current acc. IEC 60990 (measuring network Fig. 4, TN system)	<= 3.5 mA
Motor protection	Thermal overload protector (TOP) brought out
Cable exit	Variable
Protection class	I (if protective earth is connected by customer)
Product conforming to standard	EN 60335-1
Approval	CCC; EAC

AC centrifugal fan

forward curved, single inlet
with housing (large flange)

Product drawing

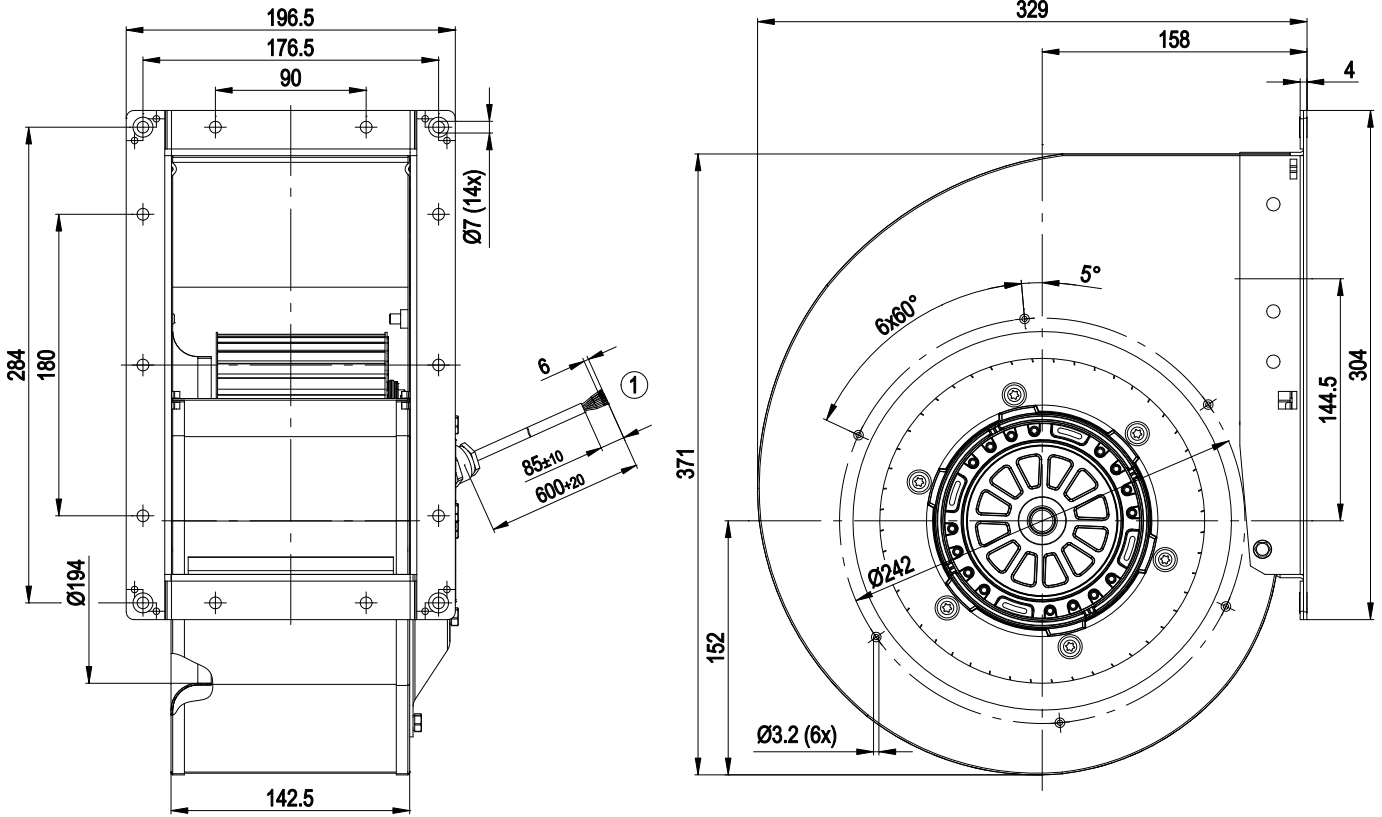

1 Connection line silicone, 6x brass lead tips crimped



AC centrifugal fan

forward curved, single inlet
with housing (large flange)

Connection screen

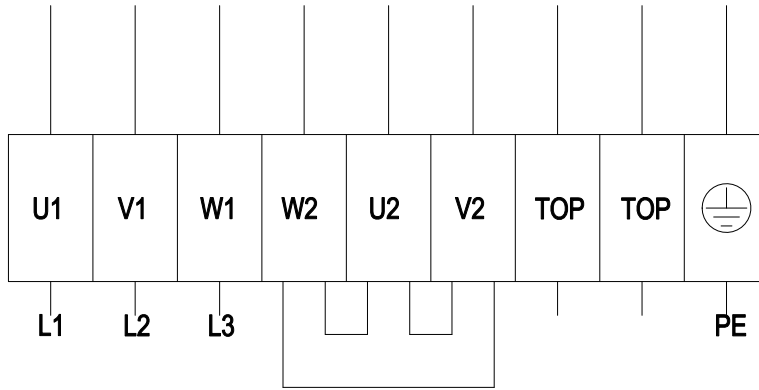

Y	Star connection	L1	= U1 = black	L2	= V1 = blue
L3	= W1 = brown	TOP	2 x grey	PE	green/yellow



AC centrifugal fan

forward curved, single inlet
with housing (large flange)

Charts: Air flow 50 Hz Y

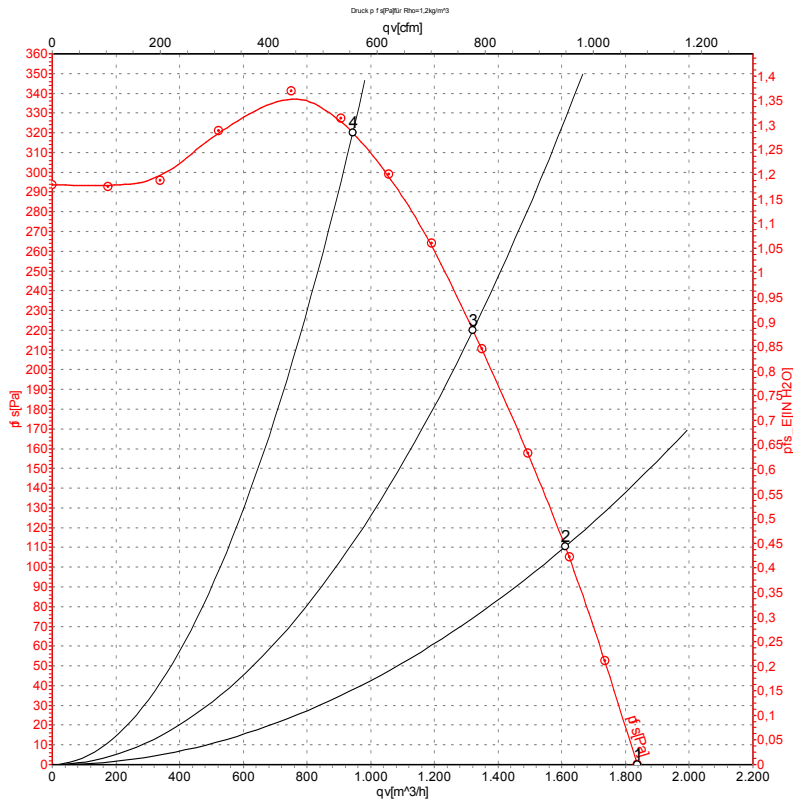

Measurement: LU-56990

Air performance measured as per ISO 5801 Installation category A. For detailed information on the measuring set-up, please contact ebm-papst. Suction-side noise levels: L_{wA} measured as per ISO 13347 / L_{pA} measured with 1m distance to fan axis. The values given are valid under the measuring conditions mentioned above and may vary according to the actual installation situation. With any deviation from the standard set-up, the specific values have to be checked and reviewed with the unit installed.

Measured values

	Conn.	U	f	n	P _e	I	qv	p _{fs}
		V	Hz	min ⁻¹	W	A	m ³ /h	Pa
1	Y	400	50	1310	460	0.85	1835	0
2	Y	400	50	1350	385	0.76	1610	110
3	Y	400	50	1390	304	0.67	1320	220
4	Y	400	50	1425	219	0.60	945	320

Conn. = Connection · U = Supply voltage · f = Frequency · n = Speed · P_e = Power input · I = Current draw · qv = Air flow · p_{fs} = Pressure increase



AC centrifugal fan

forward curved, single inlet
with housing (large flange)

Charts: Air flow 60 Hz Y

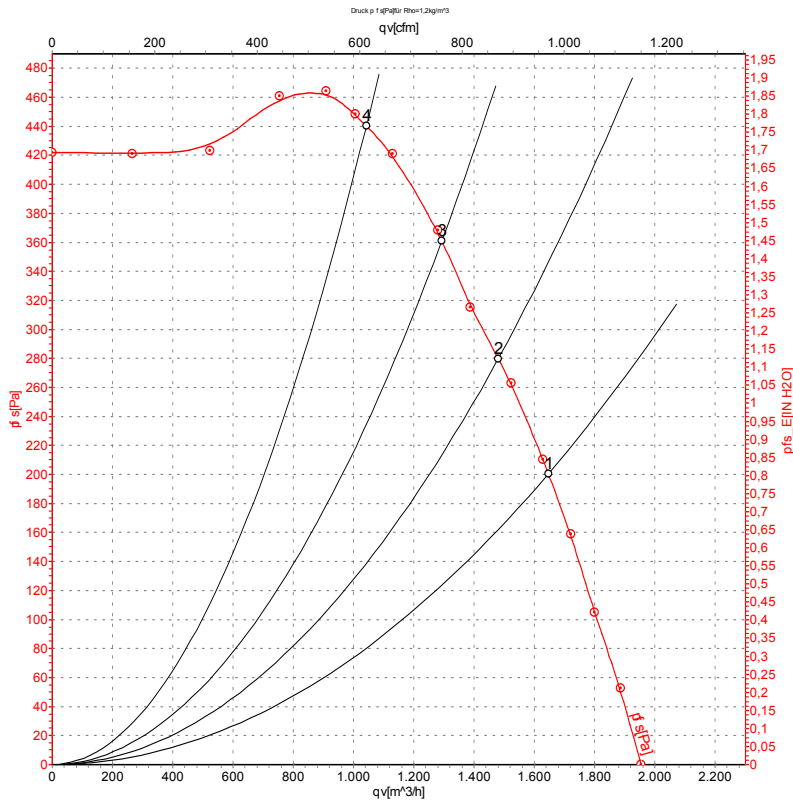

Measurement: LU-56991

Air performance measured as per ISO 5801 Installation category A. For detailed information on the measuring set-up, please contact ebm-papst. Suction-side noise levels: LwA measured as per ISO 13347 / LpA measured with 1m distance to fan axis. The values given are valid under the measuring conditions mentioned above and may vary according to the actual installation situation. With any deviation from the standard set-up, the specific values have to be checked and reviewed with the unit installed.

Measured values

	Conn.	U	f	n	P _e	I	qv	p _{fs}
		V	Hz	min ⁻¹	W	A	m ³ /h	Pa
1	Y	400	60	1520	515	0.90	1645	200
2	Y	400	60	1555	466	0.82	1480	280
3	Y	400	60	1605	390	0.70	1290	360
4	Y	400	60	1655	312	0.60	1040	440

Conn. = Connection · U = Supply voltage · f = Frequency · n = Speed · P_e = Power input · I = Current draw · qv = Air flow · p_{fs} = Pressure increase

