

G2E140-PI51-09

AC centrifugal fan

forward-curved, single-intake

with housing (flange)

ASIA PACIFIC SHENGRUI LIMITED

Phone +00852 56261528

info@apacfan.com

www.apacfan.com

Limited partnership · Headquarters Muldingen

Amtsgericht (court of registration) Stuttgart · HRA 590344

General partner Elektrobau Muldingen GmbH · Headquarters Muldingen

Amtsgericht (court of registration) Stuttgart · HRB 590142

Nominal data

Type	G2E140-PI51-09		
Motor	M2E068-DF		
Phase		1~	1~
Nominal voltage	VAC	230	230
Frequency	Hz	50	60
Method of obtaining data		ml	ml
Valid for approval/standard		-	-
Speed (rpm)	min ⁻¹	2200	2100
Power consumption	W	180	225
Current draw	A	0.8	0.99
Capacitor	µF	4	4
Capacitor voltage	VDB	450	450
Capacitor standard		S2 (CE)	S2 (CE)
Min. ambient temperature	°C	-25	-25
Max. ambient temperature	°C	60	40

ml = Max. load · me = Max. efficiency · fa = Free air · cs = Customer specification · ce = Customer equipment

Subject to change



ebmpapst

G2E140-PI51-09

AC centrifugal fan

forward-curved, single-intake
with housing (flange)

Technical description

Weight	3.6 kg
Fan size	140 mm
Rotor surface	Painted black
Impeller material	Sheet steel, painted black
Housing material	Sheet steel, galvanized
Guard grille material	Hot-dip galvanized and spot-welded net
Direction of rotation	Clockwise, viewed toward rotor
Degree of protection	IP44; installation- and position-dependent as per EN 60034-5
Insulation class	"B"
Moisture (F) / Environmental (H) protection class	H0+
Max. permitted ambient temp. for motor (transport/storage)	+ 80 °C
Min. permitted ambient temp. for motor (transport/storage)	- 40 °C
Installation position	Shaft horizontal or rotor on bottom; rotor on top on request
Condensation drainage holes	On rotor side
Mode	S1
Motor bearing	Ball bearing
Touch current according to IEC 60990 (measuring circuit Fig. 4, TN system)	< 0.75 mA
Electrical hookup	With plug
Motor protection	Thermal overload protector (TOP) with basic insulation
With cable	Variable
Protection class	I (with customer connection of protective earth)
Motor capacitor according to EN 60252-1 in safety protection class	S2
Conformity with standards	EN 60335-1
Approval	CSA C22.2 No. 100; UL 1004-1; CCC



G2E140-PI51-09

AC centrifugal fan

forward-curved, single-intake

with housing (flange)

Product drawing

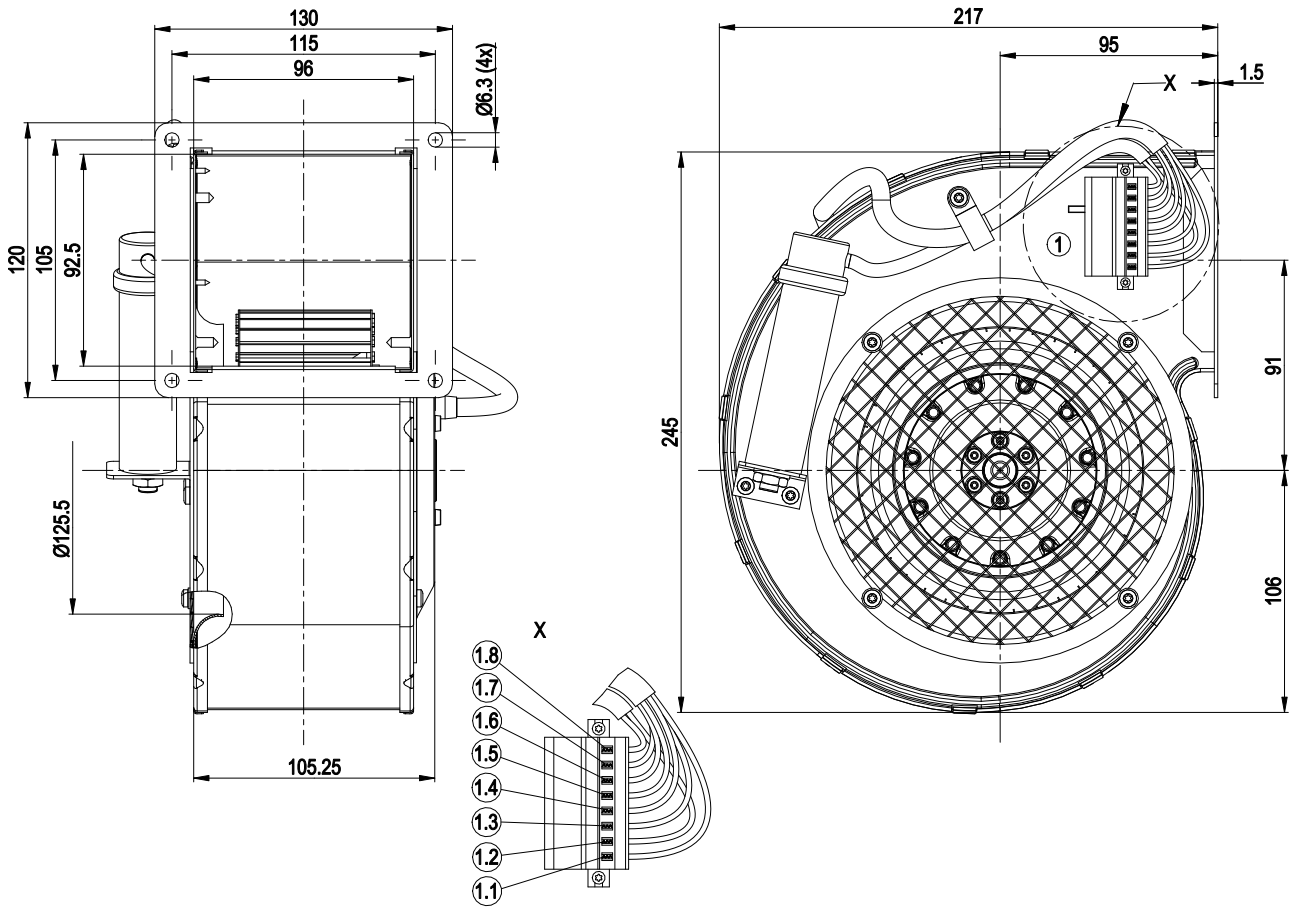

1	Cable PVC 6G AWG20, with connector housing Wago 231-608/019-000 and 6x crimped splices
1.1	Capacitor
1.2	brown
1.3	blue
1.4	gray
1.5	green/yellow
1.6	gray
1.7	Capacitor
1.8	black



G2E140-PI51-09

AC centrifugal fan

forward-curved, single-intake

with housing (flange)

Connection diagram

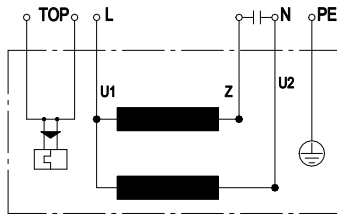

U1	blue	Z	brown	U2	black
PE	green/yellow	TOP	2x gray		



AC centrifugal fan

forward-curved, single-intake

with housing (flange)

Curves: Air performance 50 Hz

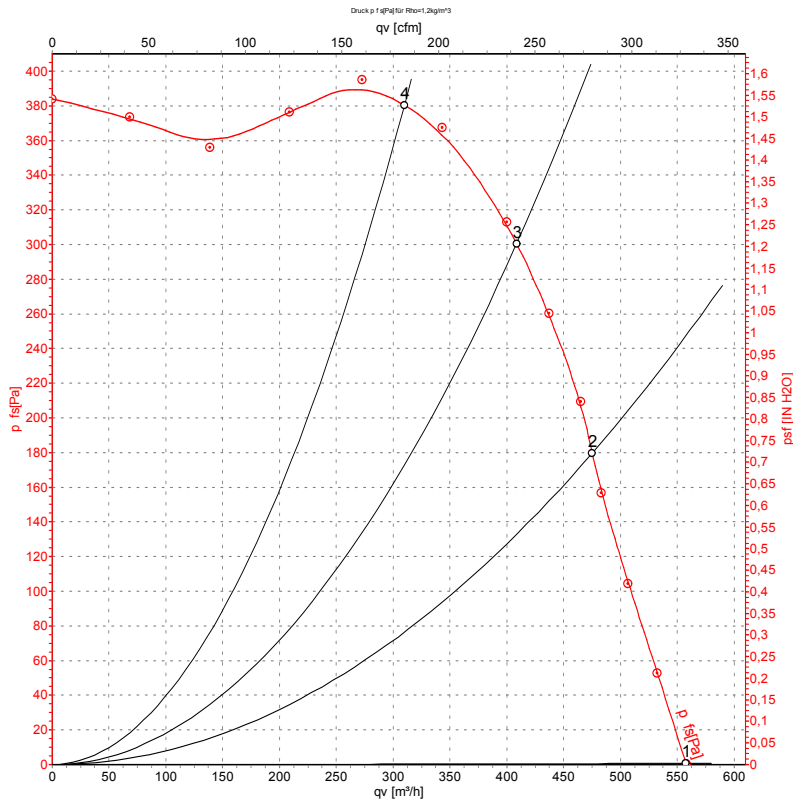

Measurement: LU-46695-1

Air performance measured according to ISO 5801 installation category A. For detailed information on the measurement setup, contact ebm-papst. Intake sound level: Sound power level according to ISO 13347 / sound pressure level measured at 1 m distance from fan axis. The values given are valid under the specified measuring conditions and may vary due to conditions of installation. For deviations from the standard configuration, the parameters have to be checked on the installed unit.

Measured values

	U	f	n	P _e	I	q _v	p _{fs}	q _v	p _{fs}
	V	Hz	min ⁻¹	W	A	m ³ /h	Pa	cfm	inH ₂ O
1	230	50	2200	180	0.80	560	0	330	0.00
2	230	50	2355	161	0.70	475	180	280	0.72
3	230	50	2470	147	0.64	410	300	240	1.20
4	230	50	2610	130	0.56	310	380	180	1.53

U = Power supply · f = Frequency · n = Speed (rpm) · P_e = Power consumption · I = Current draw · q_v = Air flow · p_{fs} = Pressure increase



AC centrifugal fan

forward-curved, single-intake

with housing (flange)

Curves: Air performance 60 Hz

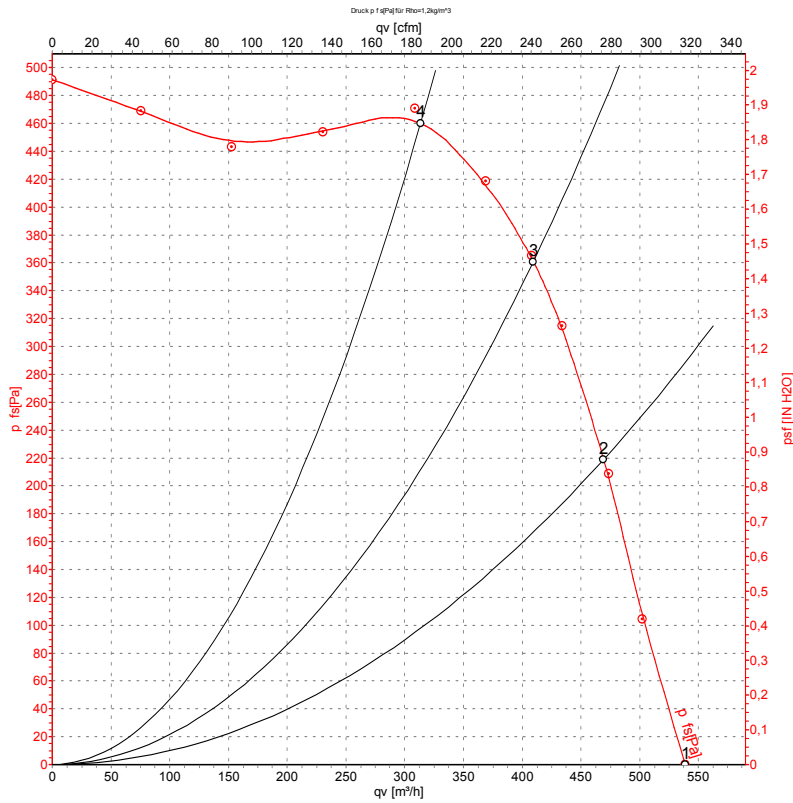

Measurement: LU-46699-1

Air performance measured according to ISO 5801 installation category A. For detailed information on the measurement setup, contact ebm-papst. Intake sound level: Sound power level according to ISO 13347 / sound pressure level measured at 1 m distance from fan axis. The values given are valid under the specified measuring conditions and may vary due to conditions of installation. For deviations from the standard configuration, the parameters have to be checked on the installed unit.

Measured values

	U	f	n	P _e	I	q _v	p _{fs}	q _v	p _{fs}
	V	Hz	min ⁻¹	W	A	m ³ /h	Pa	cfm	inH ₂ O
1	230	60	2100	225	0.99	540	0	315	0.00
2	230	60	2430	210	0.91	470	220	275	0.88
3	230	60	2640	200	0.87	410	360	240	1.45
4	230	60	2875	185	0.81	315	460	185	1.85

U = Power supply · f = Frequency · n = Speed (rpm) · P_e = Power consumption · I = Current draw · q_v = Air flow · p_{fs} = Pressure increase

