

# AC centrifugal fan

forward curved, single inlet

with housing (flange)

## ASIA PACIFIC SHENGRUI LIMITED

Phone +00852 56261528

info@apacfan.com

www.apacfan.com



### Nominal data

Type	G2D180-BD18-11		
Motor	M2D068-EC		
Phase		3~	3~
Nominal voltage	VAC	400	400
Connection		Y	Y
Frequency	Hz	50	60
Type of data definition		ml	ml
Valid for approval / standard		CE	CE
Speed	min <sup>-1</sup>	2650	2950
Power input	W	305	430
Current draw	A	0.62	0.68
Min. back pressure	Pa	700	840
Min. ambient temperature	°C	-25	-25
Max. ambient temperature	°C	50	60

ml = max. load · me = max. efficiency · fa = running at free air · cs = customer specs · cu = customer unit  
Subject to alterations

### Data according to ErP directive

		Actual	Request 2013	Request 2015
Installation category	A			
Efficiency category	Static			
Variable speed drive	No			
Specific ratio*	1.01			
Overall efficiency $\eta_{es}$		32.5	27.4	34.4
Efficiency grade N		42.1	37	44
Power input $P_e$	kW	0.3		
Air flow $q_v$	m <sup>3</sup> /h	505		
Pressure increase $p_{fs}$	Pa	701		
Speed n	min <sup>-1</sup>	2670		

Data established at point of optimum efficiency

\* Specific ratio =  $1 + p_b / 100\,000\text{ Pa}$



# AC centrifugal fan

forward curved, single inlet  
with housing (flange)

## Technical features

<b>Mass</b>	4.1 kg
<b>Size</b>	180 mm
<b>Surface of rotor</b>	Uncoated
<b>Material of impeller</b>	Sheet steel, galvanised
<b>Housing material</b>	Die-cast aluminium
<b>Direction of rotation</b>	Counter-clockwise, seen on rotor
<b>Type of protection</b>	IP 00
<b>Insulation class</b>	"F"
<b>Humidity class</b>	F1-1
<b>Max. permissible ambient motor temp. (transp./ storage)</b>	+ 80 °C
<b>Min. permissible ambient motor temp. (transp./storage)</b>	- 40 °C
<b>Mounting position</b>	Any
<b>Condensate discharge holes</b>	None, open rotor
<b>Operation mode</b>	S1
<b>Motor bearing</b>	Ball bearing
<b>Touch current acc. IEC 60990 (measuring network Fig. 4, TN system)</b>	< 0.75 mA
<b>Protection class</b>	I (if protective earth is connected by customer)
<b>Product conforming to standard</b>	EN 60335-1
<b>Approval</b>	CCC

# AC centrifugal fan

forward curved, single inlet  
with housing (flange)

## Product drawing

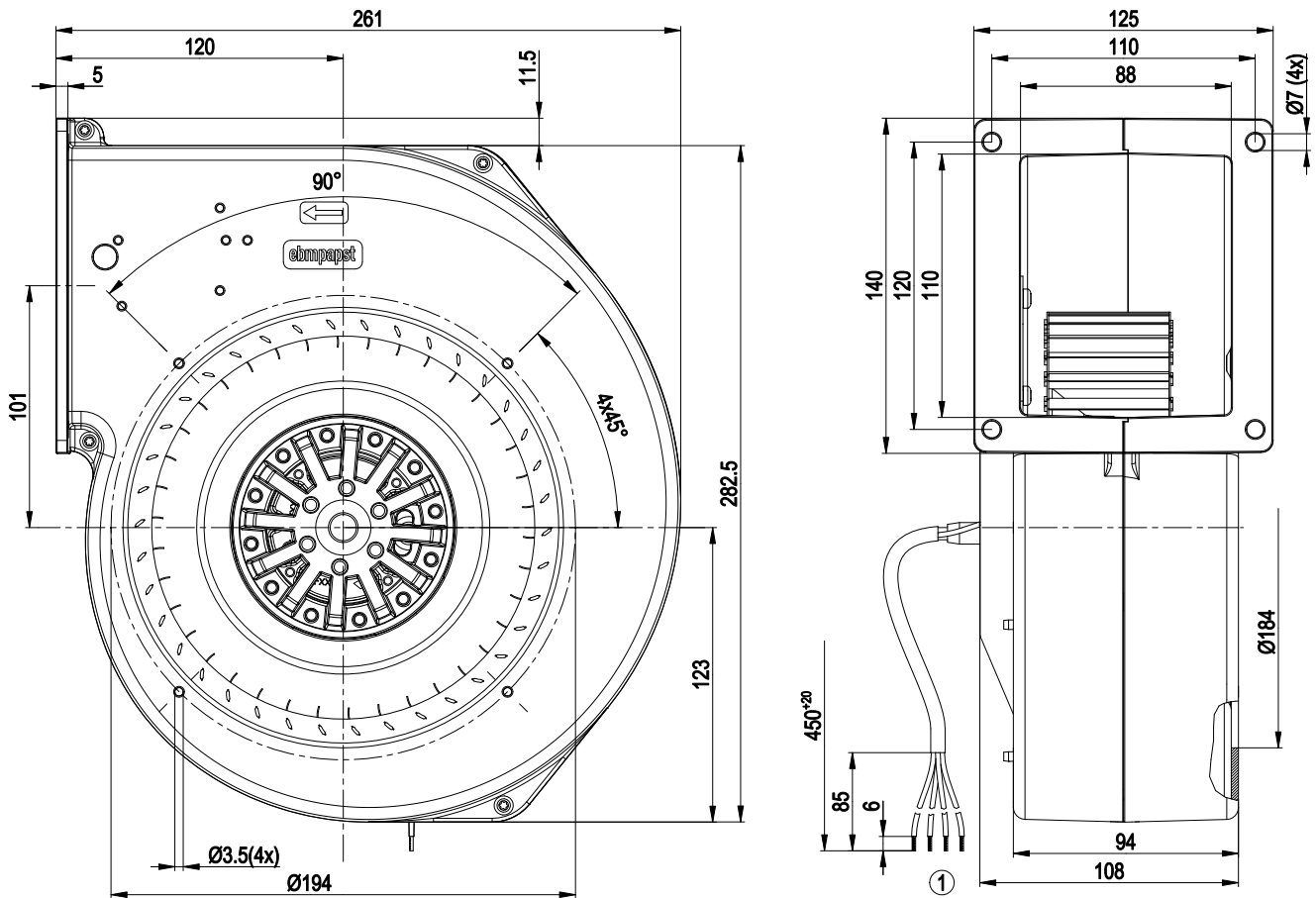

1 Connection line silicone 4G 0.5 mm<sup>2</sup>, 4 x brass lead tips crimped

## Connection screen

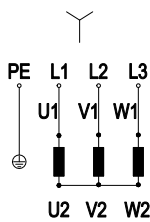

Y	Star connection	L1	black	L2	blue
L3	brown	PE	green/yellow		



# AC centrifugal fan

forward curved, single inlet  
with housing (flange)

## Charts: Air flow 50 Hz

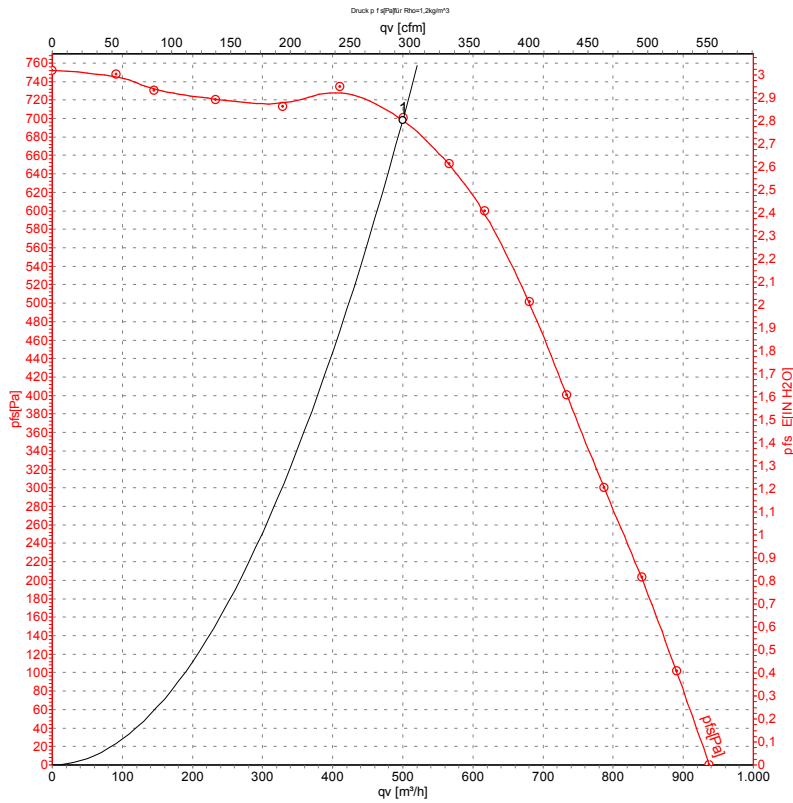

Measurement: LU-23947

Air performance measured as per ISO 5801 Installation category A. For detailed information on the measuring set-up, please contact ebm-papst. Suction-side noise levels: L<sub>WA</sub> measured as per ISO 13347 / L<sub>pA</sub> measured with 1m distance to fan axis. The values given are valid under the measuring conditions mentioned above and may vary according to the actual installation situation. With any deviation from the standard set-up, the specific values have to be checked and reviewed with the unit installed.

## Measured values

	U	f	n	P <sub>e</sub>	I	qv	p <sub>fs</sub>
	V	Hz	min <sup>-1</sup>	W	A	m <sup>3</sup> /h	Pa
1	400	50	2650	305	0.62	500	700

U = Supply voltage · f = Frequency · n = Speed · P<sub>e</sub> = Power input · I = Current draw · qv = Air flow · p<sub>fs</sub> = Pressure increase



# AC centrifugal fan

forward curved, single inlet  
with housing (flange)

## Charts: Air flow 60 Hz

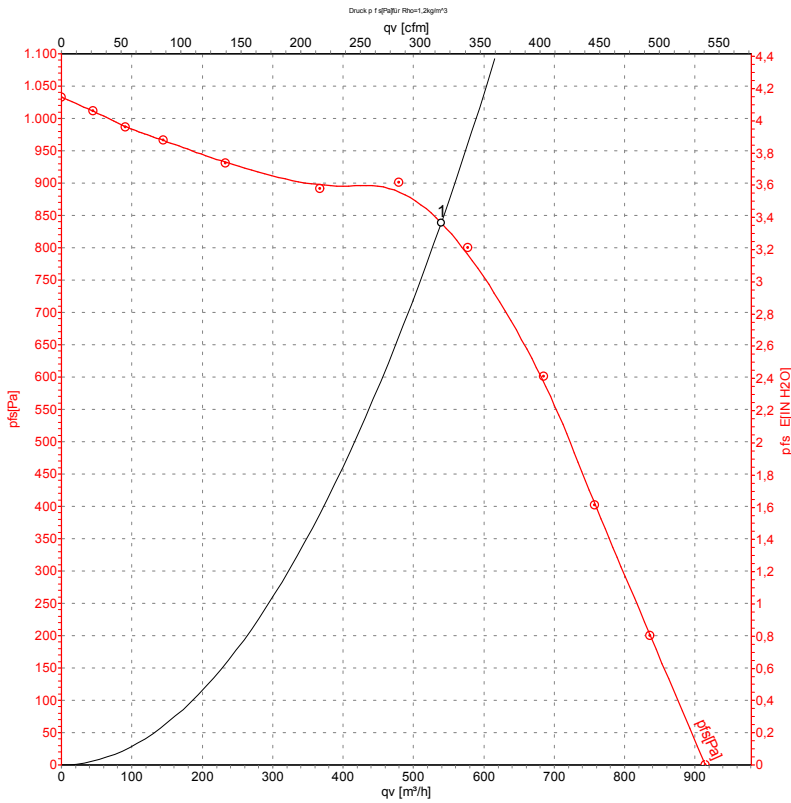

Measurement: LU-23948

Air performance measured as per ISO 5801 Installation category A. For detailed information on the measuring set-up, please contact ebm-papst. Suction-side noise levels: L<sub>wA</sub> measured as per ISO 13347 / L<sub>pA</sub> measured with 1m distance to fan axis. The values given are valid under the measuring conditions mentioned above and may vary according to the actual installation situation. With any deviation from the standard set-up, the specific values have to be checked and reviewed with the unit installed.

## Measured values

	U	f	n	P <sub>e</sub>	I	qv	p <sub>fs</sub>
	V	Hz	min <sup>-1</sup>	W	A	m <sup>3</sup> /h	Pa
1	400	60	2950	430	0.68	540	840

U = Supply voltage · f = Frequency · n = Speed · P<sub>e</sub> = Power input · I = Current draw · qv = Air flow · p<sub>fs</sub> = Pressure increase

