

G2D160-AF02-09

AC centrifugal fan

forward-curved, single-intake
with housing (flange)



ASIA PACIFIC SHENGRUI LIMITED

Phone +00852 56261528

info@apacfan.com

www.apacfan.com

Limited partnership · Headquarters Mulfingen

Amtsgericht (court of registration) Stuttgart · HRA 590344

General partner Elektrobau Mulfingen GmbH · Headquarters Mulfingen

Amtsgericht (court of registration) Stuttgart · HRB 590142

Nominal data

Type	G2D160-AF02-09		
Motor	M2D068-EC		
Phase		3~	3~
Nominal voltage	VAC	230	400
Wiring		Δ	Y
Frequency	Hz	50	50
Method of obtaining data		ml	ml
Valid for approval/standard		CE	CE
Speed (rpm)	min ⁻¹	2300	2300
Power consumption	W	305	305
Current draw	A	0.83	0.48
Min. back pressure	Pa	0	0
Min. back pressure	in. wg	0	0
Min. ambient temperature	°C	-25	-25
Max. ambient temperature	°C	50	50
Starting current	A	1.75	1.0

ml = Max. load · me = Max. efficiency · fa = Free air · cs = Customer specification · ce = Customer equipment
Subject to change

Data according to Commission Regulation (EU) 327/2011 (EN 17166)

		Actual	Req. 2015		
01 Overall efficiency η_{es}	%	32.3	32.2	09 Power consumption P_e	kW
02 Measurement category		A		09 Air flow q_v	m ³ /h
03 Efficiency category		Static		09 Pressure increase p_{fs}	Pa
04 Efficiency grade N		44.1	44	10 Speed (rpm) n	min ⁻¹
05 Variable speed drive		No		11 Specific ratio*	
					0.13
					300
					519
					2745
					1.01

Data obtained at optimum efficiency level.
The ErP data is determined using a motor-impeller combination in a standardized measurement setup.

* Specific ratio = $1 + p_{fs} / 100\,000\text{ Pa}$

LU-155189



ebmpapst

G2D160-AF02-09

AC centrifugal fan

forward-curved, single-intake
with housing (flange)

Technical description

Weight	4.3 kg
Size	160 mm
Motor size	68
Rotor surface	Unpainted
Terminal box material	Die-cast aluminum
Impeller material	Sheet steel, galvanized
Housing material	Die-cast aluminum
Direction of rotation	Clockwise, viewed toward rotor
Degree of protection	IP44; installation- and position-dependent
Insulation class	"B"
Moisture (F) / Environmental (H) protection class	H0+
Max. permitted ambient temp. for motor (transport/storage)	+ 80 °C
Min. permitted ambient temp. for motor (transport/storage)	- 40 °C
Installation position	Any
Condensation drainage holes	None
Mode	S1
Motor bearing	Ball bearing
Touch current according to IEC 60990 (measuring circuit Fig. 4, TN system)	< 0.75 mA
Electrical hookup	Terminal box
Protection class	I (if protective earth is connected by customer to the housing's connection point)
Conformity with standards	EN 60335-1, motor does not have factory-installed overheating protection; CE
Approval	EAC; CCC



AC centrifugal fan

forward-curved, single-intake
with housing (flange)

Connection diagram

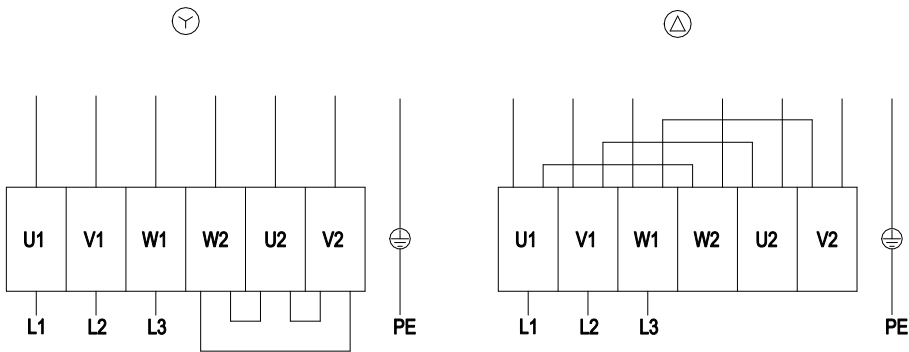

Change of rotation direction by reversing two phases

Y	Star connection	Δ	Delta connection	L1	= U1 = black
L2	= V1 = blue	L3	= W1 = brown	W2	yellow
U2	green	V2	white		

AC centrifugal fan

forward-curved, single-intake
with housing (flange)

Curves: Air performance 50 Hz

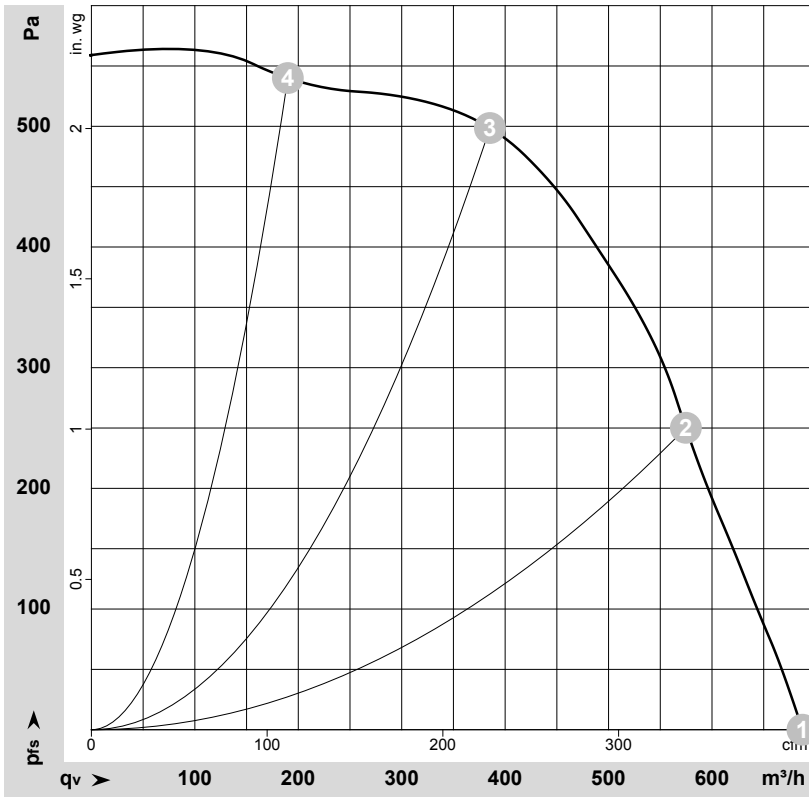

$\rho = 1.15 \text{ kg/m}^3 \pm 2 \%$

Measurement: LU-39223-1

Air performance measured according to ISO 5801 installation category A. For detailed information on the measurement setup, contact ebm-papst. Intake sound level: Sound power level according to ISO 13347 / sound pressure level measured at 1 m distance from fan axis. The values given are valid under the specified measuring conditions and may vary due to conditions of installation. For deviations from the standard configuration, the parameters have to be checked on the installed unit.

Measured values

	Wired	U	f	n	P_e	I	q_v	p_{fs}	q_v	p_{fs}
		V	Hz	min^{-1}	W	A	m^3/h	Pa	cfm	in. wg
1	Y	400	50	2300	305	0.48	685	0	405	0.00
2	Y	400	50	2475	240	0.39	575	250	340	1.00
3	Y	400	50	2685	158	0.28	385	500	225	2.01
4	Y	400	50	2830	96	0.21	190	540	110	2.17

Wired = Wiring · U = Voltage · f = Frequency · n = Speed (rpm) · P_e = Power consumption · I = Current draw · q_v = Air flow · p_{fs} = Pressure increase