

D4E225-CC01-02

AC centrifugal fan

forward curved, dual inlet
with housing (large flange)



ASIA PACIFIC SHENGRUI LIMITED

Phone +00852 56261528
info@apacfan.com
www.apacfan.com



Nominal data

Type	D4E225-CC01-02		
Motor	M4E074-LA		
Phase		1~	1~
Nominal voltage	VAC	230	230
Frequency	Hz	50	60
Type of data definition		ml	ml
Valid for approval / standard		CE	CE
Speed	min ⁻¹	1150	1300
Power input	W	650	625
Current draw	A	2.84	2.75
Motor capacitor	µF	25	16
Capacitor voltage	VDB	400	400
Capacitor standard		P2 (CE)	P2 (CE)
Min. back pressure	Pa	100	300
Min. ambient temperature	°C	-25	-25
Max. ambient temperature	°C	30	30

ml = max. load · me = max. efficiency · fa = running at free air · cs = customer specs · cu = customer unit
Subject to alterations

Data according to ErP directive

Installation category	B
Efficiency category	Total
Variable speed drive	No
Specific ratio*	1.00

* Specific ratio = $1 + p_f / 100\,000\text{ Pa}$

	Actual	Request 2013	Request 2015
Overall efficiency η_e	36.5	33.9	40.9
Efficiency grade N	44.6	42	49
Power input P_e	kW	0.53	
Air flow q_v	m ³ /h	1965	
Pressure increase p_f	Pa	361	
Speed n	min ⁻¹	1335	

Data established at point of optimum efficiency



AC centrifugal fan

forward curved, dual inlet
with housing (large flange)

Technical features

Mass	12.07 kg
Size	225 mm
Material of impeller	Sheet steel, hot-galvanised
Housing material	Sheet steel, hot-galvanised
Motor suspension	Motor anti-vibration mounted on both sides
Direction of rotation	Counter-clockwise, seen on rotor
Type of protection	IP 22
Insulation class	"B"
Humidity class	F2-1
Max. permissible ambient motor temp. (transp./ storage)	+ 80 °C
Min. permissible ambient motor temp. (transp./storage)	- 40 °C
Mounting position	Any
Condensate discharge holes	None, open rotor
Operation mode	S1
Motor bearing	Ball bearing
Touch current acc. IEC 60990 (measuring network Fig. 4, TN system)	< 0.75 mA
Motor protection	Thermal overload protector (TOP) wired internally
Protection class	I (if protective earth is connected by customer)
Product conforming to standard	EN 60335-1; CE
Approval	GOST; CCC

AC centrifugal fan

forward curved, dual inlet
with housing (large flange)

Product drawing

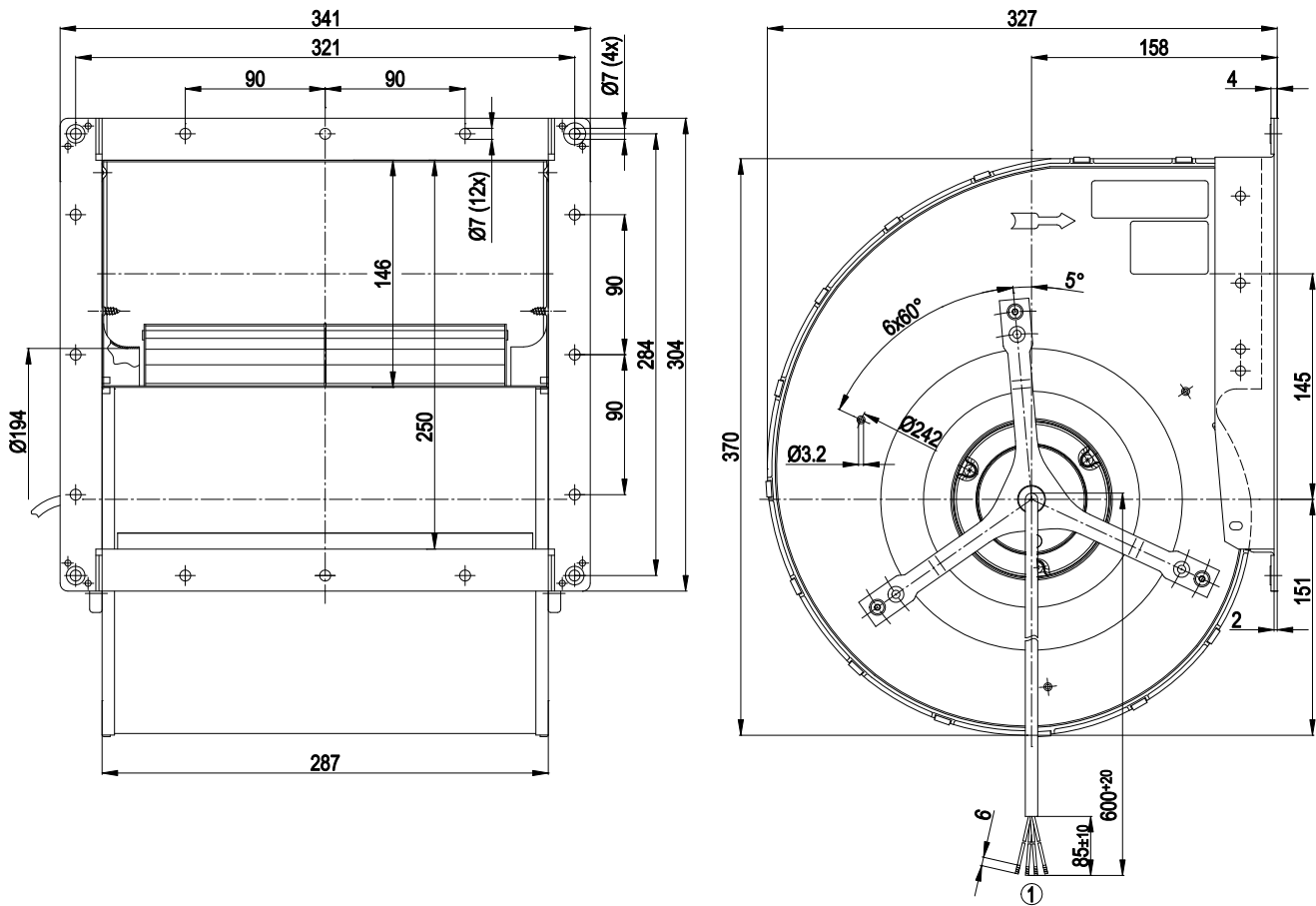

1 Connection line PVC 0.5mm², 4x brass lead tips crimped

Connection screen

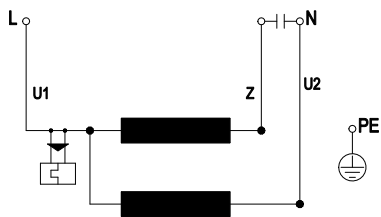

U1	blue	Z	brown	U2	black
PE	green/yellow				



AC centrifugal fan

forward curved, dual inlet
with housing (large flange)

Charts: Air flow 50 Hz

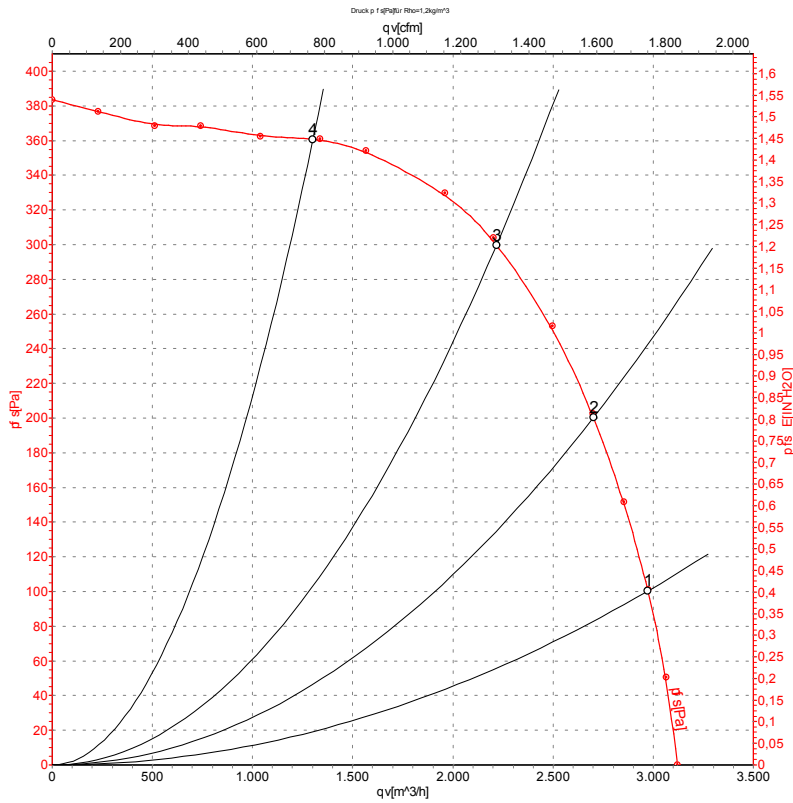

Measurement: LU-35314

Air performance measured as per ISO 5801 Installation category A. For detailed information on the measuring set-up, please contact ebm-papst. Suction-side noise levels: LwA measured as per ISO 13347 / LpA measured with 1m distance to fan axis. The values given are valid under the measuring conditions mentioned above and may vary according to the actual installation situation. With any deviation from the standard set-up, the specific values have to be checked and reviewed with the unit installed.

Measured values

	U	f	n	Pe	I	qv	Pfs
	V	Hz	min ⁻¹	W	A	m ³ /h	Pa
1	230	50	1150	783	3.42	2975	100
2	230	50	1195	689	3.05	2700	200
3	230	50	1300	581	2.65	2215	300
4	230	50	1395	445	2.15	1300	360

U = Supply voltage · f = Frequency · n = Speed · Pe = Power input · I = Current draw · qv = Air flow · Pfs = Pressure increase



AC centrifugal fan

forward curved, dual inlet
with housing (large flange)

Charts: Air flow 60 Hz

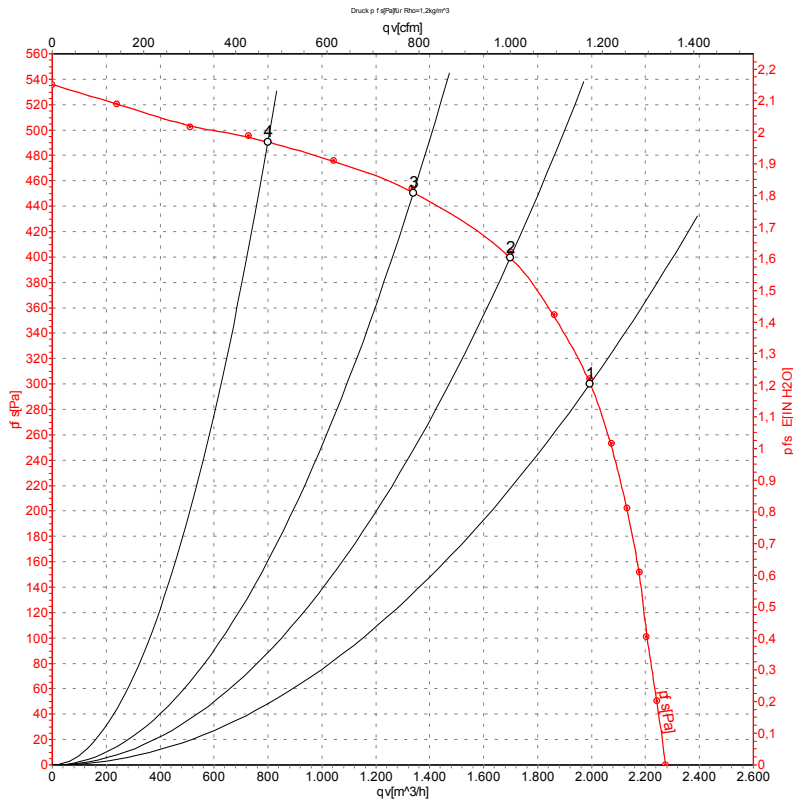

Measurement: LU-35316

Air performance measured as per ISO 5801 Installation category A. For detailed information on the measuring set-up, please contact ebm-papst. Suction-side noise levels: L_{WA} measured as per ISO 13347 / L_{pA} measured with 1m distance to fan axis. The values given are valid under the measuring conditions mentioned above and may vary according to the actual installation situation. With any deviation from the standard set-up, the specific values have to be checked and reviewed with the unit installed.

Measured values

	U	f	n	P _e	I	qv	P _{fs}
	V	Hz	min ⁻¹	W	A	m ³ /h	Pa
1	230	60	1300	646	2.81	1995	300
2	230	60	1465	553	2.43	1700	400
3	230	60	1565	474	2.13	1340	450
4	230	60	1645	390	1.83	800	490

U = Supply voltage · f = Frequency · n = Speed · P_e = Power input · I = Current draw · qv = Air flow · p_{fs} = Pressure increase

