

D2E146-HT67-01

AC centrifugal fan

forward curved, dual inlet
with housing (flange)



ASIA PACIFIC SHENGRUI LIMITED

Phone +00852 56261528

info@apacfan.com

www.apacfan.com



Nominal data

Type	D2E146-HT67-01		
Motor	M2E068-EC		
Phase		1~	1~
Nominal voltage	VAC	230	230
Frequency	Hz	50	60
Type of data definition		ml	ml
Valid for approval / standard		CE	CE
Speed	min ⁻¹	1850	2100
Power input	W	355	400
Current draw	A	1.55	1.75
Motor capacitor	μF	8	8
Capacitor voltage	VDB	450	450
Capacitor standard		P2 (CE)	P2 (CE)
Min. back pressure	Pa	0	200
Max. ambient temperature	°C	55	50
Starting current	A	1.8	1.9

ml = max. load · me = max. efficiency · fa = running at free air · cs = customer specs · cu = customer unit
Subject to alterations

Data according to ErP directive

Installation category	A
Efficiency category	Static
Variable speed drive	No
Specific ratio*	1.00

* Specific ratio = $1 + p_g / 100\,000\text{ Pa}$

	Actual	Request 2013	Request 2015
Overall efficiency η_{es}	29	27	34
Efficiency grade N	39	37	44
Power input P_e	kW	0.26	
Air flow q_v	m ³ /h	700	
Pressure increase p_{fs}	Pa	400	
Speed n	min ⁻¹	2435	

Data established at point of optimum efficiency



AC centrifugal fan

forward curved, dual inlet
with housing (flange)

Technical features

Mass	3.44 kg
Size	146 mm
Surface of rotor	Partially cast in aluminium
Material of terminal box	PP plastic, black
Material of impeller	Sheet steel, hot-galvanised
Housing material	PP plastic, black
Motor suspension	Motor anti-vibration mounted on both sides
Direction of rotation	Counter-clockwise, seen on rotor
Type of protection	IP 20
Insulation class	"F"
Humidity class	F0
Max. permissible ambient motor temp. (transp./ storage)	+ 80 °C
Min. permissible ambient motor temp. (transp./storage)	- 40 °C
Mounting position	Shaft horizontal or rotor on bottom; rotor on top on request
Condensate discharge holes	None, open rotor
Operation mode	S1
Motor bearing	Calotte bearing
Speed steps	4
Touch current acc. IEC 60990 (measuring network Fig. 4, TN system)	< 0.75 mA
Electrical leads	With plug; Via terminal box, integrated capacitor connected via terminal box
Motor protection	Thermal overload protector (TOP) wired internally
Cable exit	Variable
Protection class	I (if protective earth is connected by customer)
Product conforming to standard	EN 60335-1; CE
Approval	GOST; CCC; VDE

AC centrifugal fan

forward curved, dual inlet
with housing (flange)

Product drawing

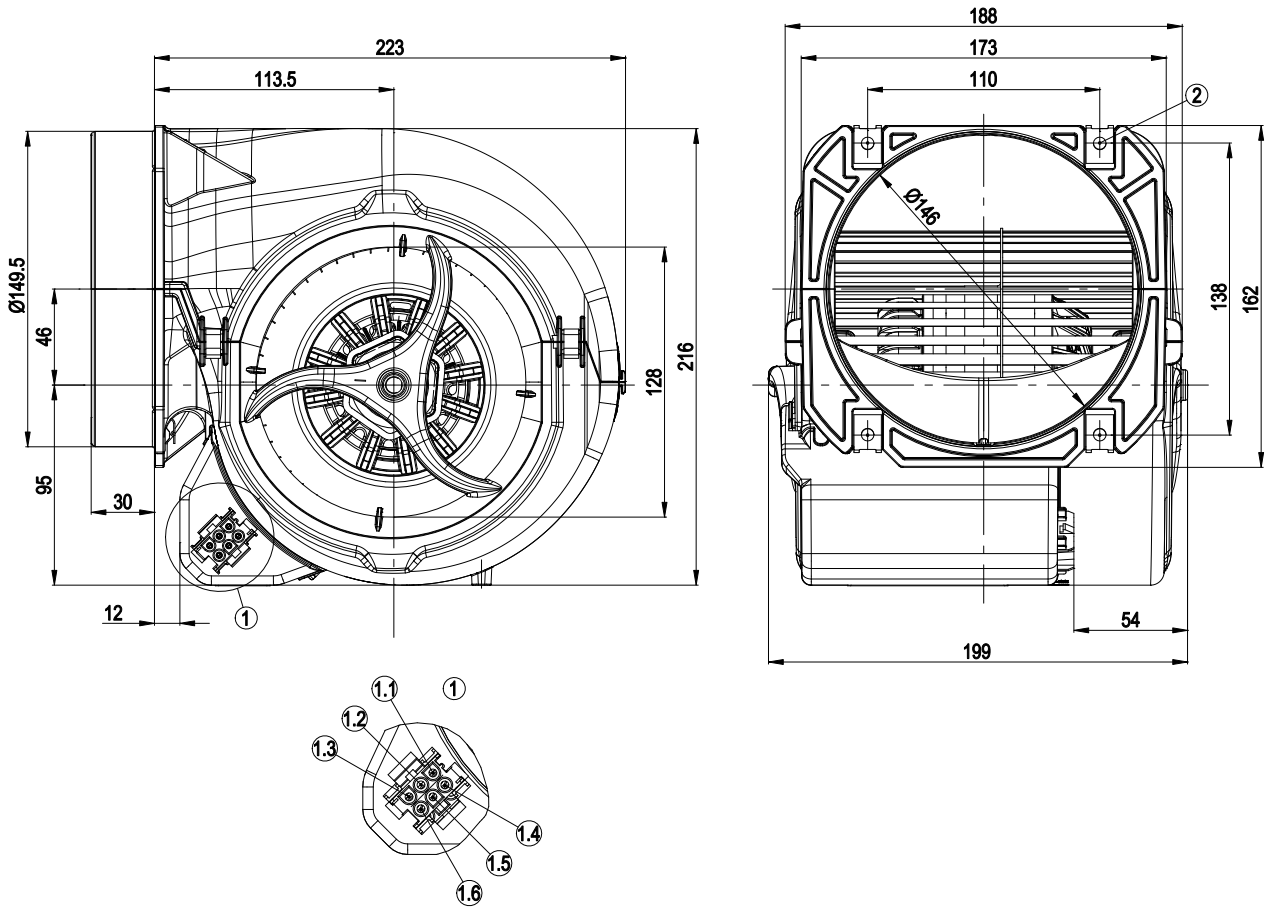

1	AMP Universal Mate-N-Lok coded plug system; connector shell: AMP 926 682-3; 6x plug pin: AMP 926 886-1
1.1	L = step 1
1.2	L = step 2
1.3	L = step 3
1.4	L = step 4
1.5	N
1.6	Protective earth
2	4 x sheet metal nut for thread EN ISO 1478-ST4.8 (min. screw length 14.5 mm plus thickness of mounting material)



AC centrifugal fan

forward curved, dual inlet
with housing (flange)

Connection screen

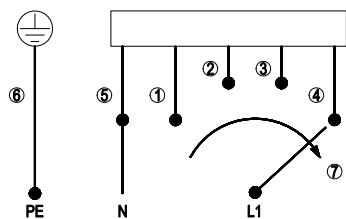

When changing speeds, switch must break the circuit

1	Step 1 (min.)	2	Step 2	3	Step 3
4	Step 4 (max.)	5	N	6	PE protective earth
7	Speed increase				

AC centrifugal fan

forward curved, dual inlet
with housing (flange)

Charts: Air flow 50 Hz

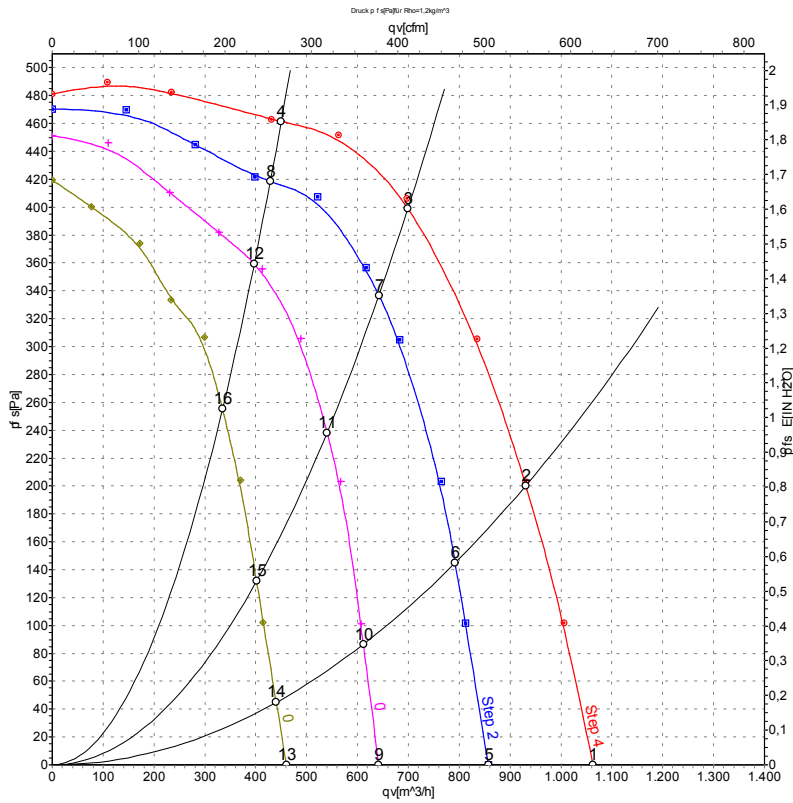

Measurement: LU-45713
Measurement: LU-45715
Measurement: LU-45717
Measurement: LU-45719

Air performance measured as per ISO 5801 Installation category A. For detailed information on the measuring set-up, please contact ebm-papst. Suction-side noise levels: LwA measured as per ISO 13347 / LpA measured with 1m distance to fan axis. The values given are valid under the measuring conditions mentioned above and may vary according to the actual installation situation. With any deviation from the standard set-up, the specific values have to be checked and reviewed with the unit installed.

Measured values

	Stage	U	f	n	P _e	I	qv	P _{fs}
		V	Hz	min ⁻¹	W	A	m ³ /h	Pa
1	4	230	50	1850	355	1.55	1060	0
2	4	230	50	2150	318	1.38	930	200
3	4	230	50	2435	268	1.16	700	400
4	4	230	50	2610	227	0.99	450	460
5	3	230	50	1550	286	1.27	855	0
6	3	230	50	1850	261	1.18	790	145
7	3	230	50	2235	222	1.03	640	337
8	3	230	50	2515	179	0.87	430	418
9	2	230	50	1195	233	1.06	640	0
10	2	230	50	1455	222	1.02	610	88
11	2	230	50	1890	196	0.94	540	239
12	2	230	50	2315	158	0.81	395	360
13	1	230	50	875	195	0.89	460	0
14	1	230	50	1055	191	0.88	440	45
15	1	230	50	1420	179	0.84	400	132
16	1	230	50	1965	151	0.76	335	255

U = Supply voltage · f = Frequency · n = Speed · P_e = Power input · I = Current draw · qv = Air flow · P_{fs} = Pressure increase



AC centrifugal fan

forward curved, dual inlet

with housing (flange)

Charts: Air flow 60 Hz

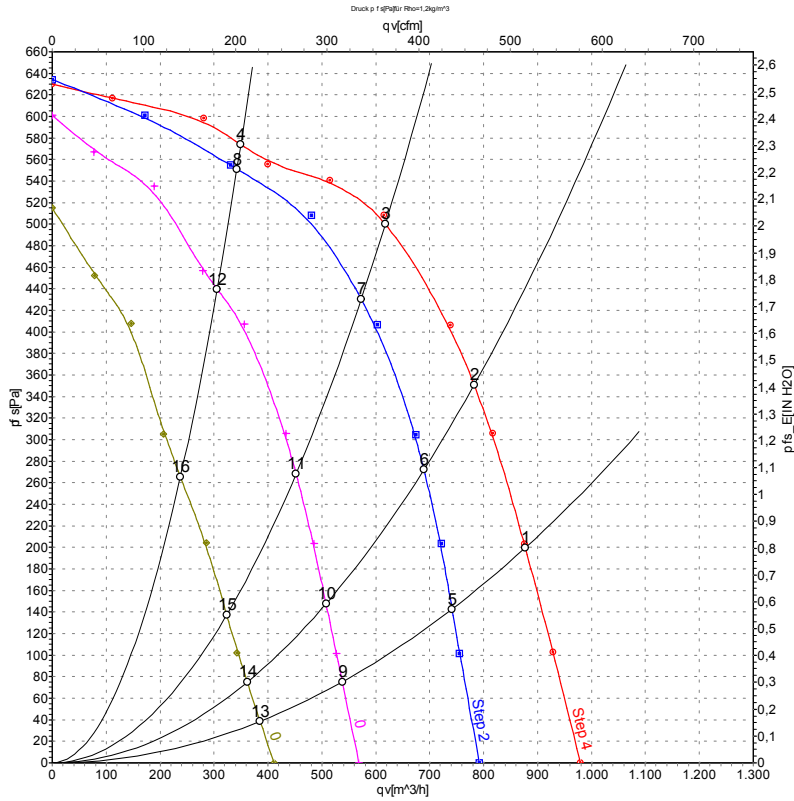

Measurement: LU-45714
 Measurement: LU-45716
 Measurement: LU-45718
 Measurement: LU-45720

Air performance measured as per ISO 5801 Installation category A. For detailed information on the measuring set-up, please contact ebm-papst. Suction-side noise levels: L_{wA} measured as per ISO 13347 / L_{pA} measured with 1m distance to fan axis. The values given are valid under the measuring conditions mentioned above and may vary according to the actual installation situation. With any deviation from the standard set-up, the specific values have to be checked and reviewed with the unit installed.

Measured values

	Stage	U	f	n	P _e	I	qv	P _{fs}
		V	Hz	min ⁻¹	W	A	m ³ /h	Pa
1	4	230	60	2100	400	1.75	875	200
2	4	230	60	2360	384	1.67	780	350
3	4	230	60	2685	360	1.58	620	500
4	4	230	60	2935	335	1.48	350	575
5	3	230	60	1780	296	1.37	740	143
6	3	230	60	2085	284	1.34	690	273
7	3	230	60	2495	260	1.29	575	432
8	3	230	60	2870	226	1.22	345	552
9	2	230	60	1325	228	1.10	540	75
10	2	230	60	1560	222	1.09	510	148
11	2	230	60	1990	210	1.07	450	268
12	2	230	60	2575	181	1.02	305	439
13	1	230	60	950	187	0.92	385	38
14	1	230	60	1105	185	0.91	360	74
15	1	230	60	1400	180	0.90	325	137
16	1	230	60	1985	165	0.88	240	265

U = Supply voltage · f = Frequency · n = Speed · P_e = Power input · I = Current draw · qv = Air flow · p_{fs} = Pressure increase

