

D2E146-HS97-03

AC centrifugal fan

forward curved, dual inlet
with housing (flange)

ASIA PACIFIC SHENGRUI LIMITED
Phone +00852 56261528
info@apacfan.com
www.apacfan.com

Nominal data

| | | | |
|-------------------------------|-------------------|---------|---------|
| Type | D2E146-HS97-03 | | |
| Motor | M2E068-DF | | |
| Phase | | 1~ | 1~ |
| Nominal voltage | VAC | 230 | 230 |
| Frequency | Hz | 50 | 60 |
| Type of data definition | | fa | ml |
| Valid for approval / standard | | CE | CE |
| Speed (rpm) | min ⁻¹ | 1350 | 1750 |
| Power input | W | 195 | 215 |
| Current draw | A | 0.86 | 0.94 |
| Motor capacitor | μF | 5 | 5 |
| Capacitor voltage | VDB | 400 | 400 |
| Capacitor standard | | S2 (CE) | S2 (CE) |
| Min. back pressure | Pa | 0 | 150 |
| Min. ambient temperature | °C | -25 | -25 |
| Max. ambient temperature | °C | 45 | 40 |

ml = Max. load · me = Max. efficiency · fa = Running at free air · cs = Customer specs · cu = Customer unit
Subject to alterations



AC centrifugal fan

forward curved, dual inlet
with housing (flange)

Technical features

| | |
|---|--|
| Mass | 3 kg |
| Size | 146 mm |
| Surface of rotor | Partially cast in aluminium |
| Material of terminal box | PP plastic, black |
| Material of impeller | PP plastic, white |
| Housing material | PP plastic, black |
| Motor suspension | Motor anti-vibration mounted on both sides |
| Direction of rotation | Counter-clockwise, seen on rotor |
| Type of protection | IP 20 |
| Insulation class | "F" |
| Humidity (F)/environmental protection class (H) | H0 - dry environment |
| Max. permissible ambient motor temp. (transp./ storage) | + 80 °C |
| Min. permissible ambient motor temp. (transp./storage) | - 40 °C |
| Mounting position | Any |
| Condensate discharge holes | None, open rotor |
| Operation mode | S1 |
| Motor bearing | Ball bearing |
| Speed steps | 4 |
| Touch current acc. IEC 60990 (measuring network Fig. 4, TN system) | < 0.75 mA |
| Electrical leads | With plug; Via terminal box, integrated capacitor connected via terminal box |
| Motor protection | Thermal overload protector (TOP) wired internally |
| Cable exit | Variable |
| Protection class | I (if protective earth is connected by customer) |
| Motor capacitor according to EN 60252-1 in safety protection class | S2 |
| Product conforming to standard | EN 60335-2-31; CE |
| Approval | CCC; VDE; EAC |

AC centrifugal fan

forward curved, dual inlet
with housing (flange)

Product drawing

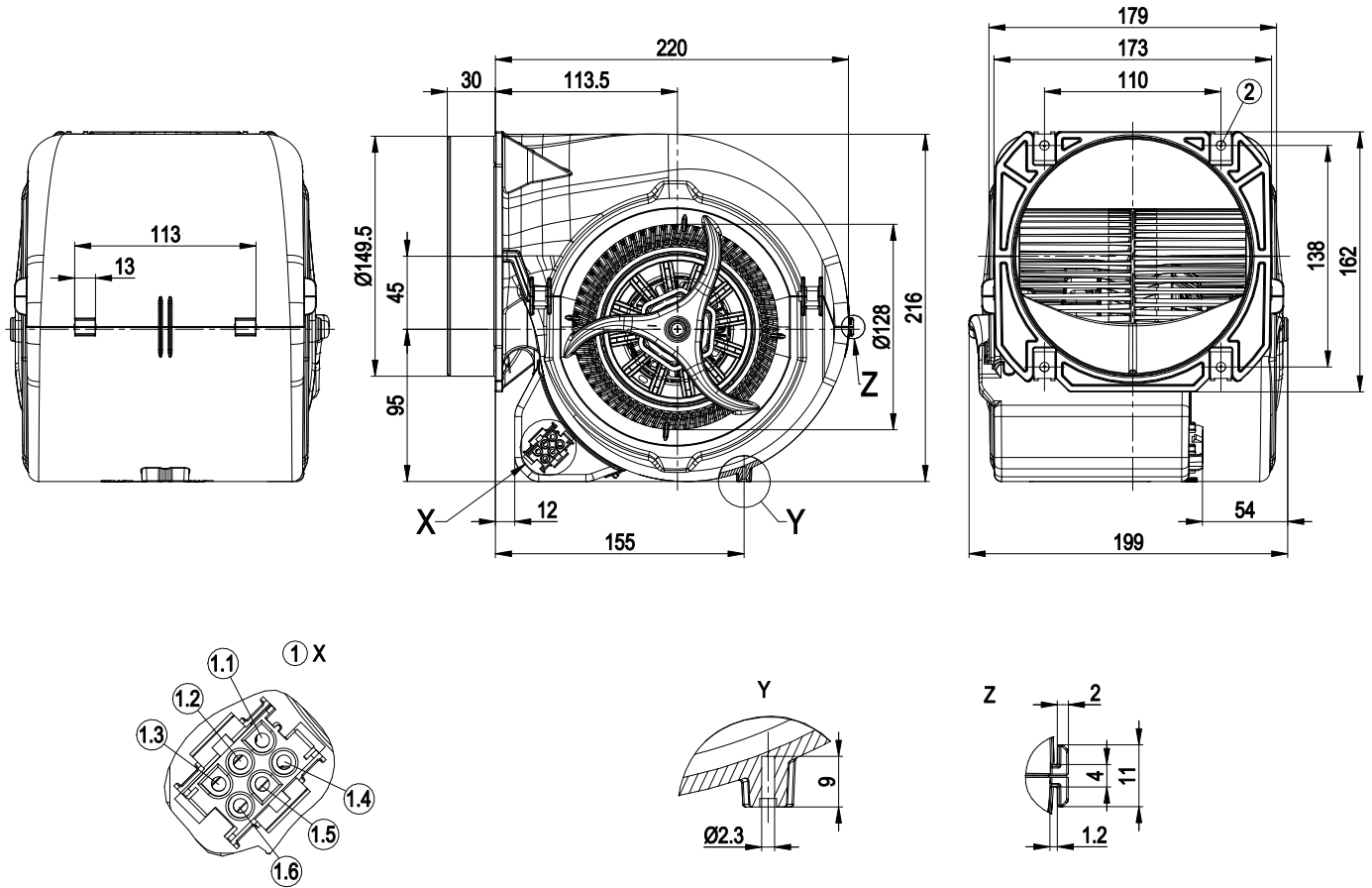

| | |
|-----|--|
| 1 | AMP Universal Mate-N-Lok coded plug system; connector shell: AMP 926 682-3; 6x plug pin: AMP 926 886-1 |
| 1.1 | L = stage 1 |
| 1.2 | L = step 2 |
| 1.3 | L = stage 3 |
| 1.4 | L = stage 4 |
| 1.5 | N |
| 1.6 | Protective earth |
| 2 | 4 x sheet metal nut for thread EN ISO 1478-ST4.8 (min. screw length 14.5 mm plus thickness of mounting material) |

AC centrifugal fan

forward curved, dual inlet
with housing (flange)

Connection screen

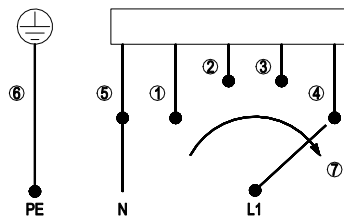

When changing speeds, switch must break the circuit

| | | | | | |
|---|----------------|---|--------|---|---------------------|
| 1 | Step 1 (min.) | 2 | Step 2 | 3 | Step 3 |
| 4 | Step 4 (max.) | 5 | N | 6 | PE protective earth |
| 7 | Speed increase | | | | |

AC centrifugal fan

forward curved, dual inlet
with housing (flange)

Charts: Air flow 50 Hz

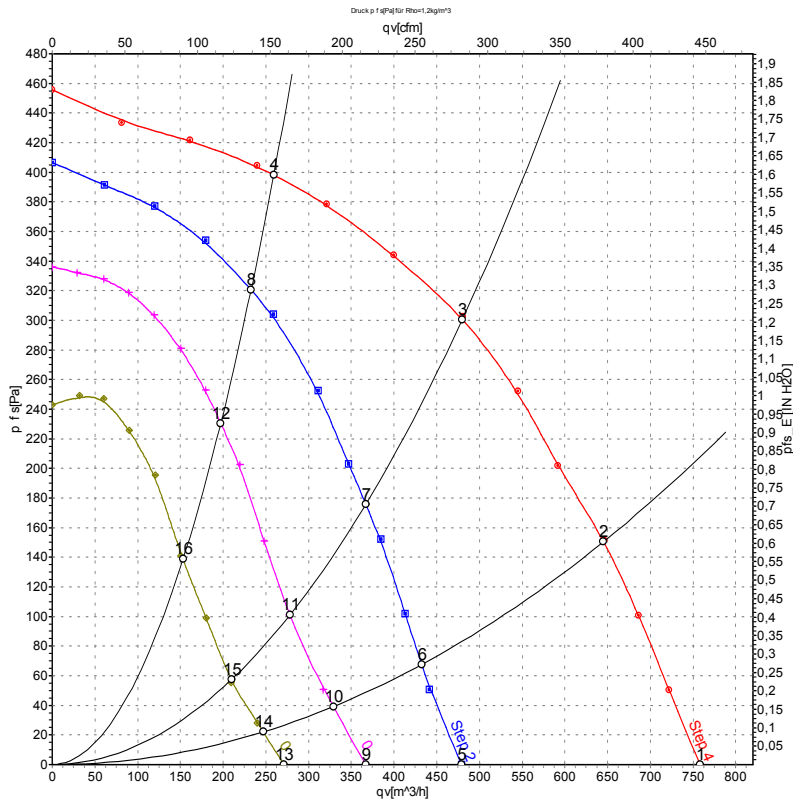

Measurement: LU-72087-1
Measurement: LU-72089-1
Measurement: LU-72091-1
Measurement: LU-72094-1

Air performance measured as per ISO 5801 Installation category A. For detailed information on the measuring set-up, please contact ebm-papst. Suction-side noise levels: LwA measured as per ISO 13347 / LpA measured with 1m distance to fan axis. The values given are valid under the measuring conditions mentioned above and may vary according to the actual installation situation. With any deviation from the standard set-up, the specific values have to be checked and reviewed with the unit installed.

Measured values

| | Stage | U | f | n | Pe | I | LpA _{in} | LwA _{in} | qv | Pfs | qv | Pfs |
|----|-------|-----|----|-------------------|-----|------|-------------------|-------------------|-------------------|-----|-----|-------|
| | | V | Hz | min ⁻¹ | W | A | dB(A) | dB(A) | m ³ /h | Pa | cfm | inH2O |
| 1 | 4 | 230 | 50 | 1350 | 195 | 0.86 | 53 | 65 | 760 | 0 | 445 | 0.00 |
| 2 | 4 | 230 | 50 | 1795 | 185 | 0.81 | 53 | 65 | 645 | 150 | 380 | 0.60 |
| 3 | 4 | 230 | 50 | 2200 | 169 | 0.75 | 55 | 67 | 480 | 300 | 285 | 1.20 |
| 4 | 4 | 230 | 50 | 2520 | 146 | 0.65 | 58 | 70 | 260 | 400 | 150 | 1.61 |
| 5 | 3 | 230 | 50 | 875 | 128 | 0.61 | 42 | 54 | 480 | 0 | 280 | 0.00 |
| 6 | 3 | 230 | 50 | 1215 | 125 | 0.60 | 43 | 55 | 430 | 67 | 255 | 0.27 |
| 7 | 3 | 230 | 50 | 1680 | 116 | 0.58 | 49 | 61 | 365 | 176 | 215 | 0.71 |
| 8 | 3 | 230 | 50 | 2255 | 94 | 0.52 | 56 | 68 | 235 | 321 | 135 | 1.29 |
| 9 | 2 | 230 | 50 | 660 | 109 | 0.53 | 35 | 46 | 365 | 0 | 215 | 0.00 |
| 10 | 2 | 230 | 50 | 915 | 106 | 0.52 | 36 | 48 | 330 | 38 | 195 | 0.15 |
| 11 | 2 | 230 | 50 | 1280 | 102 | 0.51 | 43 | 54 | 280 | 100 | 165 | 0.40 |
| 12 | 2 | 230 | 50 | 1920 | 88 | 0.48 | 52 | 64 | 195 | 230 | 115 | 0.92 |
| 13 | 1 | 230 | 50 | 510 | 95 | 0.47 | 27 | 39 | 270 | 0 | 160 | 0.00 |
| 14 | 1 | 230 | 50 | 715 | 94 | 0.47 | 28 | 40 | 245 | 22 | 145 | 0.09 |
| 15 | 1 | 230 | 50 | 960 | 92 | 0.46 | 34 | 46 | 210 | 55 | 125 | 0.22 |
| 16 | 1 | 230 | 50 | 1515 | 85 | 0.44 | 46 | 58 | 155 | 138 | 90 | 0.55 |

U = Supply voltage · f = Frequency · n = Speed (rpm) · Pe = Power input · I = Current draw · LpA_{in} = Sound pressure level inlet side · LwA_{in} = Sound power level inlet side · qv = Air flow
Pfs = Pressure increase



AC centrifugal fan

forward curved, dual inlet
with housing (flange)

Charts: Air flow 60 Hz

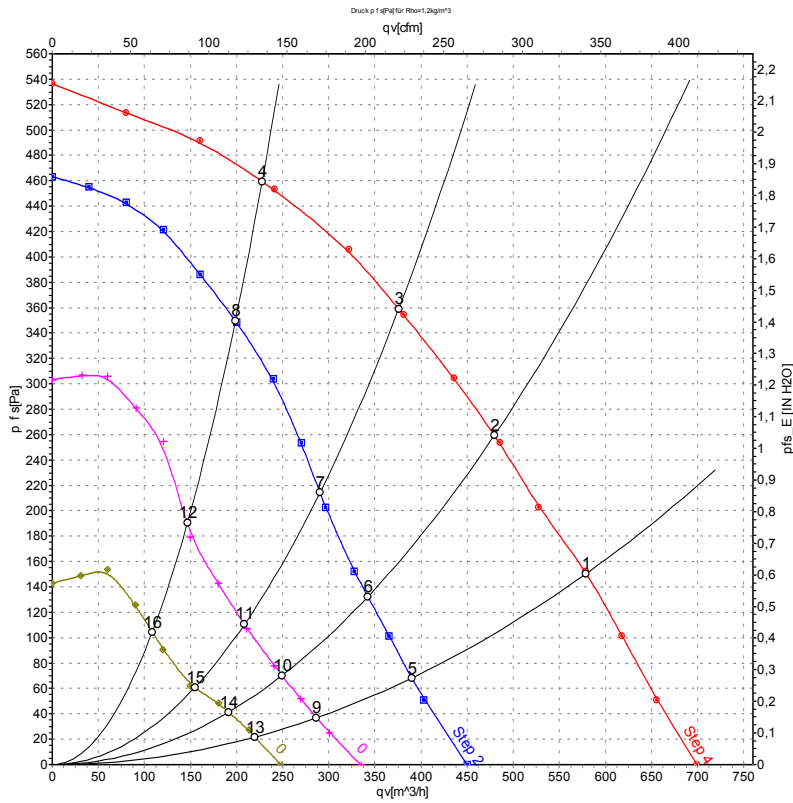

Measurement: LU-72088-1
Measurement: LU-72090-1
Measurement: LU-72092-1
Measurement: LU-72095-1

Air performance measured as per ISO 5801 Installation category A. For detailed information on the measuring set-up, please contact ebmpapst. Suction-side noise levels: LwA measured as per ISO 13347 / LpA measured with 1m distance to fan axis. The values given are valid under the measuring conditions mentioned above and may vary according to the actual installation situation. With any deviation from the standard set-up, the specific values have to be checked and reviewed with the unit installed.

Measured values

| | Stage | U | f | n | P _e | I | q _v | P _{fs} | q _v | P _{fs} |
|----|-------|-----|----|-------------------|----------------|------|-------------------|-----------------|----------------|-----------------|
| | | V | Hz | min ⁻¹ | W | A | m ³ /h | Pa | cfm | inH2O |
| 1 | 4 | 230 | 60 | 1750 | 215 | 0.94 | 580 | 150 | 340 | 0.60 |
| 2 | 4 | 230 | 60 | 2060 | 212 | 0.93 | 480 | 260 | 280 | 1.04 |
| 3 | 4 | 230 | 60 | 2380 | 208 | 0.91 | 375 | 360 | 220 | 1.45 |
| 4 | 4 | 230 | 60 | 2710 | 201 | 0.89 | 230 | 460 | 135 | 1.85 |
| 5 | 3 | 230 | 60 | 1175 | 131 | 0.67 | 390 | 68 | 230 | 0.27 |
| 6 | 3 | 230 | 60 | 1485 | 129 | 0.67 | 340 | 132 | 200 | 0.53 |
| 7 | 3 | 230 | 60 | 1855 | 125 | 0.66 | 290 | 214 | 170 | 0.86 |
| 8 | 3 | 230 | 60 | 2365 | 114 | 0.65 | 200 | 350 | 115 | 1.41 |
| 9 | 2 | 230 | 60 | 890 | 106 | 0.57 | 285 | 37 | 170 | 0.15 |
| 10 | 2 | 230 | 60 | 1100 | 105 | 0.57 | 250 | 70 | 145 | 0.28 |
| 11 | 2 | 230 | 60 | 1365 | 104 | 0.57 | 210 | 110 | 120 | 0.44 |
| 12 | 2 | 230 | 60 | 1835 | 99 | 0.56 | 145 | 187 | 85 | 0.75 |
| 13 | 1 | 230 | 60 | 665 | 92 | 0.50 | 220 | 22 | 130 | 0.09 |
| 14 | 1 | 230 | 60 | 820 | 91 | 0.50 | 190 | 41 | 115 | 0.16 |
| 15 | 1 | 230 | 60 | 1010 | 90 | 0.50 | 155 | 60 | 90 | 0.24 |
| 16 | 1 | 230 | 60 | 1325 | 88 | 0.50 | 110 | 104 | 65 | 0.42 |

U = Supply voltage · f = Frequency · n = Speed (rpm) · P_e = Power input · I = Current draw · q_v = Air flow · p_{fs} = Pressure increase

