

D2E146-AP47-22

# AC centrifugal fan

forward curved, dual inlet  
with housing (flange)



**ASIA PACIFIC SHENGRUI LIMITED**  
Phone +00852 56261528  
info@apacfan.com  
www.apacfan.com



## Nominal data

<b>Type</b>	D2E146-AP47-22		
<b>Motor</b>	M2E068-EC		
Phase		1~	1~
Nominal voltage	VAC	230	230
Frequency	Hz	50	60
Type of data definition		ml	ml
Valid for approval / standard		CE	CE
Speed	min <sup>-1</sup>	2050	2550
Power input	W	300	330
Current draw	A	1.31	1.45
Motor capacitor	µF	8	8
Capacitor voltage	VDB	400	400
Min. back pressure	Pa	200	400
Min. ambient temperature	°C	-25	-25
Max. ambient temperature	°C	30	25

ml = max. load · me = max. efficiency · fa = running at free air · cs = customer specs · cu = customer unit  
Subject to alterations

## Data according to ErP directive

Installation category	A
Efficiency category	Static
Variable speed drive	No
Specific ratio*	1.00

\* Specific ratio =  $1 + p_{fs} / 100\,000\text{ Pa}$

	Actual	Request 2013	Request 2015
Overall efficiency $\eta_{es}$	28.2	26.8	33.8
Efficiency grade N	38.4	37	44
Power input $P_e$	kW	0.24	
Air flow $q_v$	m <sup>3</sup> /h	705	
Pressure increase $p_{fs}$	Pa	351	
Speed n	min <sup>-1</sup>	2435	

Data established at point of optimum efficiency



# AC centrifugal fan

forward curved, dual inlet  
with housing (flange)

## Technical features

<b>Mass</b>	4.2 kg
<b>Size</b>	146 mm
<b>Surface of rotor</b>	Uncoated
<b>Material of impeller</b>	Sendzimir galvanized sheet steel
<b>Housing material</b>	Sendzimir galvanized sheet steel
<b>Motor suspension</b>	Motor mounted via brackets on one side
<b>Direction of rotation</b>	Counter-clockwise, seen on rotor
<b>Type of protection</b>	IP 44
<b>Insulation class</b>	"B"
<b>Humidity class</b>	F0
<b>Max. permissible ambient motor temp. (transp./ storage)</b>	+ 80 °C
<b>Min. permissible ambient motor temp. (transp./storage)</b>	- 40 °C
<b>Mounting position</b>	Any
<b>Condensate discharge holes</b>	None
<b>Operation mode</b>	Continuous operation (S1)
<b>Motor bearing</b>	Ball bearing
<b>Touch current acc. IEC 60990 (measuring network Fig. 4, TN system)</b>	< 0.75 mA
<b>Motor protection</b>	Thermal overload protector (TOP) wired internally
<b>Cable exit</b>	Axial
<b>Protection class</b>	I (if protective earth is connected by customer)
<b>Product conforming to standard</b>	CE
<b>Approval</b>	CCC; GOST



# AC centrifugal fan

forward curved, dual inlet  
with housing (flange)

## Product drawing

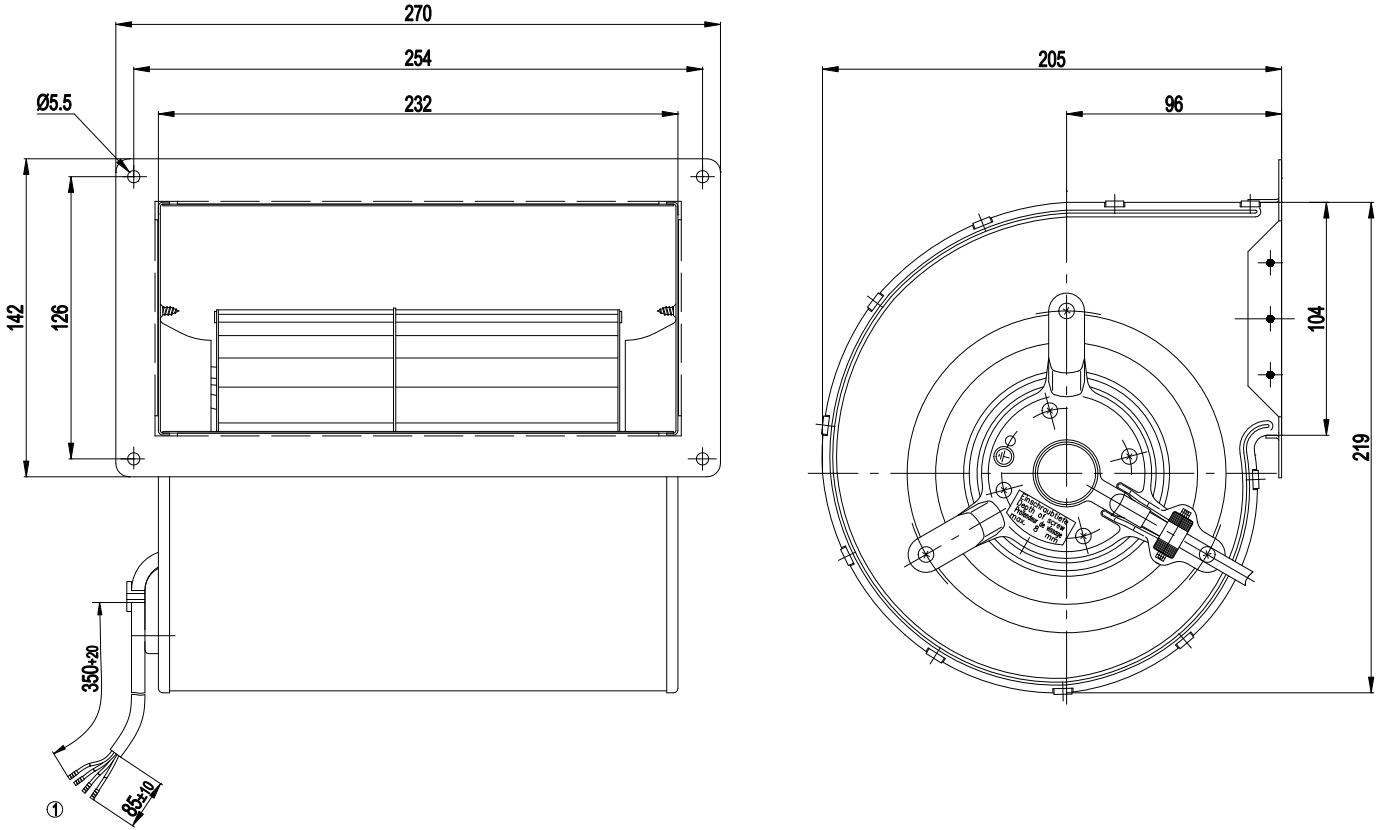

1 Connection line PVC, 4x brass lead tips crimped

## Connection screen

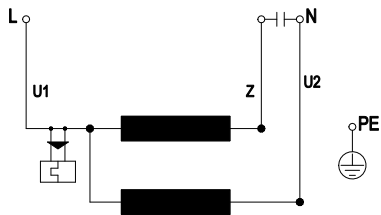

U1	blue	Z	brown	U2	black
PE	green/yellow				



# AC centrifugal fan

forward curved, dual inlet

with housing (flange)

## Charts: Air flow 50 Hz Y

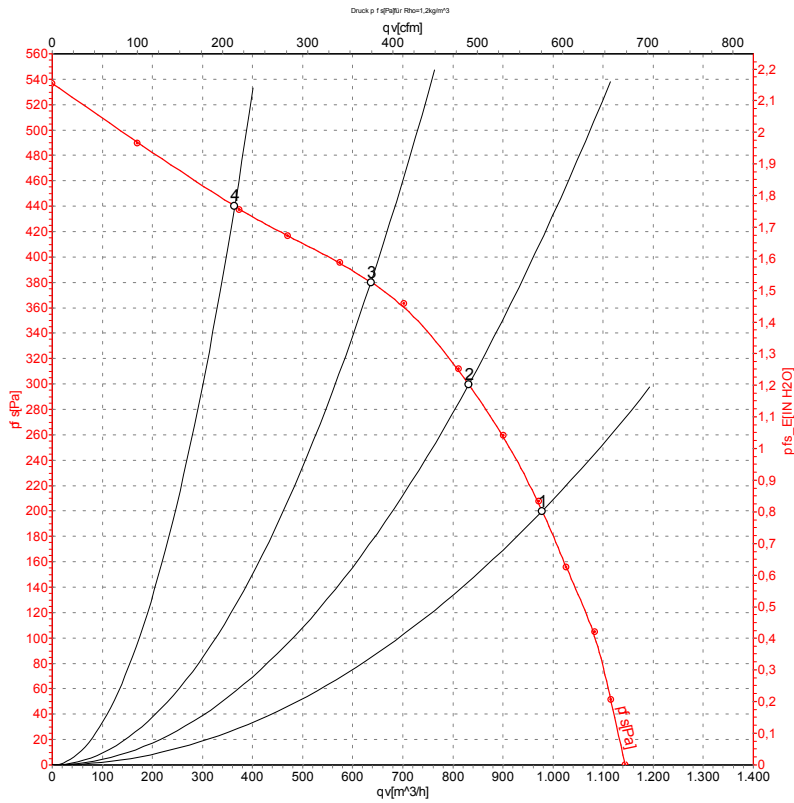

Measurement: LU-32744

Air performance measured as per ISO 5801 Installation category A. For detailed information on the measuring set-up, please contact ebm-papst. Suction-side noise levels: LwA measured as per ISO 13347 / LpA measured with 1m distance to fan axis. The values given are valid under the measuring conditions mentioned above and may vary according to the actual installation situation. With any deviation from the standard set-up, the specific values have to be checked and reviewed with the unit installed.

## Measured values

	Conn.	U	f	n	P <sub>e</sub>	I	qv	P <sub>fs</sub>
		V	Hz	min <sup>-1</sup>	W	A	m <sup>3</sup> /h	Pa
1	Y	230	50	2050	300	1.31	970	200
2	Y	230	50	2265	267	1.18	830	300
3	Y	230	50	2490	232	1.02	635	380
4	Y	230	50	2675	191	0.84	365	440

Conn. = Connection · U = Supply voltage · f = Frequency · n = Speed · P<sub>e</sub> = Power input · I = Current draw · qv = Air flow · P<sub>fs</sub> = Pressure increase



# AC centrifugal fan

forward curved, dual inlet  
with housing (flange)

## Charts: Air flow 60 Hz Y

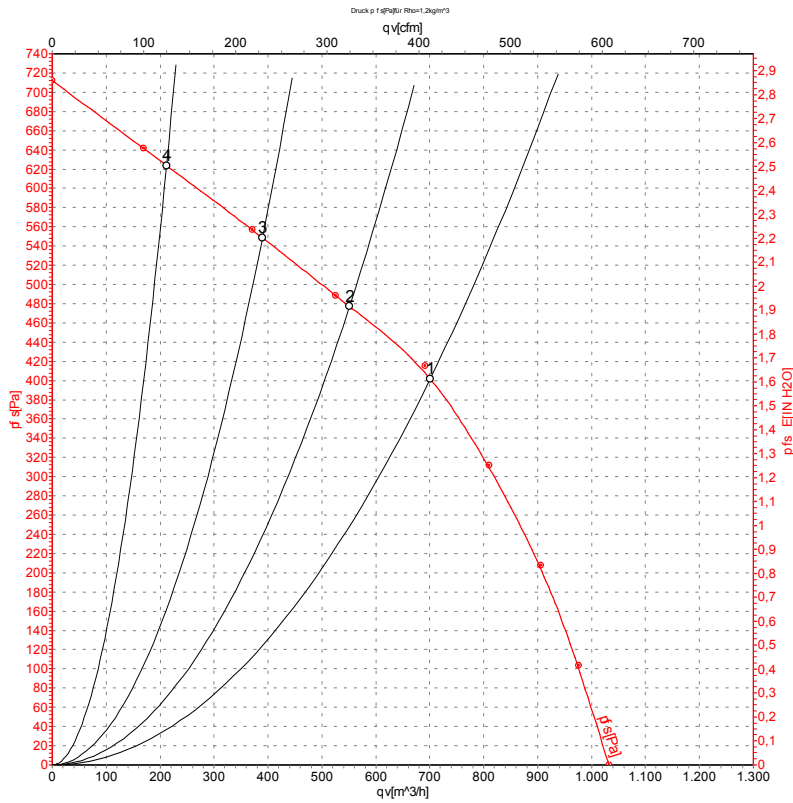

Measurement: LU-32745

Air performance measured as per ISO 5801 Installation category A. For detailed information on the measuring set-up, please contact ebm-papst. Suction-side noise levels: L<sub>wA</sub> measured as per ISO 13347 / L<sub>pA</sub> measured with 1m distance to fan axis. The values given are valid under the measuring conditions mentioned above and may vary according to the actual installation situation. With any deviation from the standard set-up, the specific values have to be checked and reviewed with the unit installed.

## Measured values

	Conn.	U	f	n	P <sub>e</sub>	I	qv	p <sub>fs</sub>
		V	Hz	min <sup>-1</sup>	W	A	m <sup>3</sup> /h	Pa
1	Y	230	60	2550	330	1.45	700	400
2	Y	230	60	2770	300	1.36	550	475
3	Y	230	60	2975	277	1.28	390	550
4	Y	230	60	3095	260	1.22	210	625

Conn. = Connection · U = Supply voltage · f = Frequency · n = Speed · P<sub>e</sub> = Power input · I = Current draw · qv = Air flow · p<sub>fs</sub> = Pressure increase

