

D2E133-AM47-01

AC centrifugal fan

forward curved, dual inlet
with housing (without flange)

ASIA PACIFIC SHENGRUI LIMITED

Phone +00852 56261528

info@apacfan.com

www.apacfan.com

Nominal data

Type	D2E133-AM47-01			
Motor	M2E068-DF			
Phase		1~	1~	1~
Nominal voltage	VAC	230	230	230
Frequency	Hz	50	50	60
Type of data definition		ml	fa	ml
Valid for approval / standard		CE	CE	CE
Speed	min ⁻¹	1900	1500	1800
Power input	W	164	190	200
Current draw	A	0.72	0.84	0.88
Motor capacitor	µF	3	3	3
Capacitor voltage	VDB	450	450	450
Min. back pressure	Pa	100	0	100
Min. ambient temperature	°C	-25	-25	-25
Max. ambient temperature	°C	55	35	25
Starting current	A	0.9	0.9	0.9

ml = max. load · me = max. efficiency · fa = running at free air · cs = customer specs · cu = customer unit
Subject to alterations



AC centrifugal fan

forward curved, dual inlet
with housing (without flange)

Technical features

Mass	3.48 kg
Size	133 mm
Surface of rotor	Partially cast in aluminium
Material of impeller	Sheet steel, hot-galvanised
Housing material	Sheet steel, hot-galvanised
Motor suspension	Motor mounted via brackets on one side
Direction of rotation	Clockwise, seen on rotor
Type of protection	IP 44; Depending on installation and position
Insulation class	"B"
Humidity class	F0
Max. permissible ambient motor temp. (transp./ storage)	+ 80 °C
Min. permissible ambient motor temp. (transp./storage)	- 40 °C
Mounting position	Any
Condensate discharge holes	None
Operation mode	S1
Motor bearing	Ball bearing
Touch current acc. IEC 60990 (measuring network Fig. 4, TN system)	< 0.75 mA
Motor protection	Thermal overload protector (TOP) wired internally
Cable exit	Axial
Protection class	I (if protective earth is connected by customer)
Product conforming to standard	EN 60335-1; CE
Approval	CCC

AC centrifugal fan

forward curved, dual inlet
with housing (without flange)

Product drawing

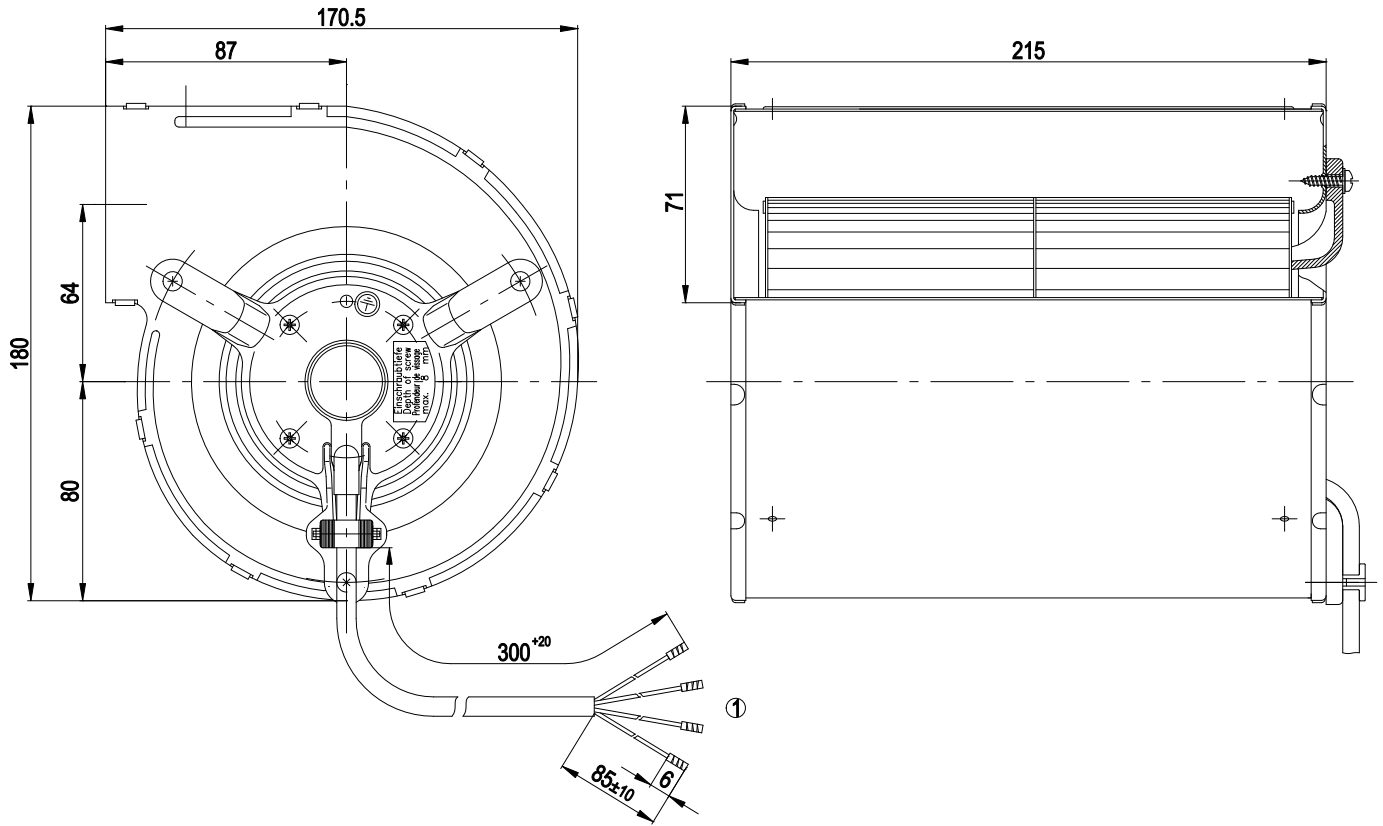

1 Connection line PVC, 4x brass lead tips crimped

Connection screen

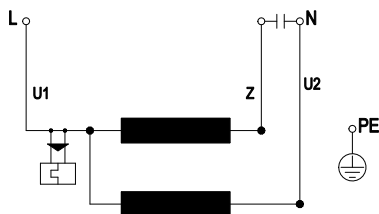

U1	blue	Z	brown	U2	black
PE	green/yellow				



AC centrifugal fan

forward curved, dual inlet
with housing (without flange)

Charts: Air flow 50 Hz

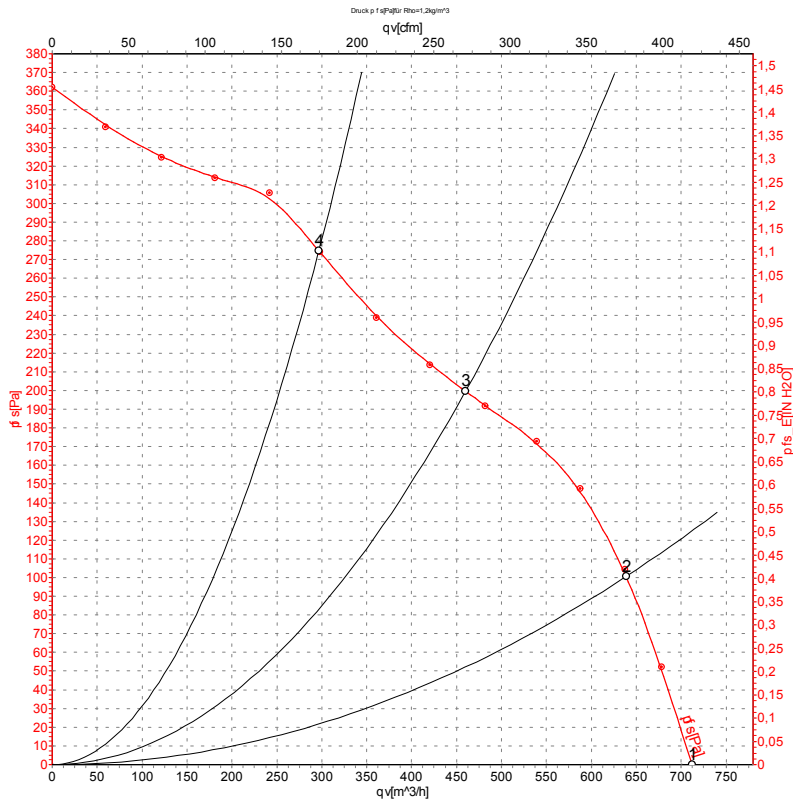

Measurement: LU-105263

Air performance measured as per ISO 5801 Installation category A. For detailed information on the measuring set-up, please contact ebm-papst. Suction-side noise levels: L_{wA} measured as per ISO 13347 / L_{pA} measured with 1m distance to fan axis. The values given are valid under the measuring conditions mentioned above and may vary according to the actual installation situation. With any deviation from the standard set-up, the specific values have to be checked and reviewed with the unit installed.

Measured values

	U	f	n	P _e	I	qv	P _{fs}
	V	Hz	min ⁻¹	W	A	m ³ /h	Pa
1	230	50	1500	190	0.84	710	0
2	230	50	1890	164	0.72	640	100
3	230	50	2310	141	0.61	460	200
4	230	50	2570	118	0.52	295	275

U = Supply voltage · f = Frequency · n = Speed · P_e = Power input · I = Current draw · qv = Air flow · P_{fs} = Pressure increase



AC centrifugal fan

forward curved, dual inlet
with housing (without flange)

Charts: Air flow 60 Hz

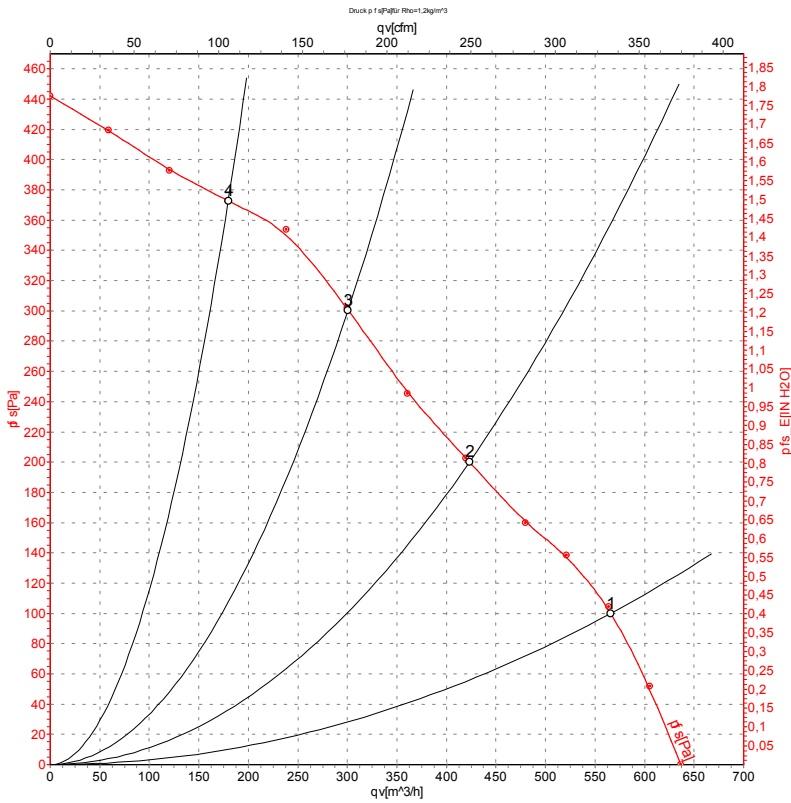

Measurement: LU-105265

Air performance measured as per ISO 5801 Installation category A. For detailed information on the measuring set-up, please contact ebm-papst. Suction-side noise levels: L_{wA} measured as per ISO 13347 / L_{pA} measured with 1m distance to fan axis. The values given are valid under the measuring conditions mentioned above and may vary according to the actual installation situation. With any deviation from the standard set-up, the specific values have to be checked and reviewed with the unit installed.

Measured values

	U	f	n	P _e	I	qv	P _{fs}
	V	Hz	min ⁻¹	W	A	m ³ /h	Pa
1	230	60	1800	200	0.88	565	100
2	230	60	2310	181	0.78	425	200
3	230	60	2685	170	0.74	300	300
4	230	60	2945	159	0.70	180	375

U = Supply voltage · f = Frequency · n = Speed · P_e = Power input · I = Current draw · qv = Air flow · P_{fs} = Pressure increase

