

AC centrifugal fan

forward curved, dual inlet
with housing and angle bracket

ASIA PACIFIC SHENGRUI LIMITED

Phone +00852 56261528

info@apacfan.com

www.apacfan.com



Nominal data

Type	D2D160-CE02-11				
Motor	M2D074-LA				
Phase		3~	3~	3~	3~
Nominal voltage	VAC	230	230	400	400
Connection		Δ	Δ	Y	Y
Frequency	Hz	50	60	50	60
Type of data definition		ml	ml	ml	ml
Valid for approval / standard		CE	CE	CE	CE
Speed	min ⁻¹	2700	2960	2700	2960
Power input	W	700	1055	700	1055
Current draw	A	1.9	2.82	1.1	1.63
Min. back pressure	Pa	460	560	460	560
Min. ambient temperature	°C	-25	-25	-25	-25
Max. ambient temperature	°C	90	50	90	50
Starting current	A	9.25	9.6	5.34	5.54

ml = Max. load · me = Max. efficiency · fa = Running at free air · cs = Customer specs · cu = Customer unit
Subject to alterations

Data according to ErP directive

Installation category	A
Efficiency category	Static
Variable speed drive	No
Specific ratio*	1.01

* Specific ratio = $1 + p_{fs} / 100\,000\text{ Pa}$

		Actual	Request 2013	Request 2015
Overall efficiency η_{es}	%	35.9	28.9	35.9
Efficiency grade N		44	37	44
Power input P_e	kW	0.52		
Air flow q_v	m ³ /h	1205		
Pressure increase p_{fs}	Pa	551		
Speed n	min ⁻¹	2795		

Data definition with optimum efficiency. LU-154175
The ErP data is determined using a motor-impeller combination in a standardised measurement configuration.



AC centrifugal fan

forward curved, dual inlet
with housing and angle bracket

Technical features

Mass	11.1 kg
Size	160 mm
Surface of rotor	Coated in black
Material of impeller	Sheet steel, galvanised
Housing material	Sheet steel, galvanised
Material of guard grille	Steel, coated in grey plastic (RAL 9006)
Motor suspension	Motor mounted anti-vibration on both sides
Direction of rotation	Counter-clockwise, seen on rotor
Type of protection	IP 00
Insulation class	"F"
Humidity class	F1-2
Max. permissible ambient motor temp. (transp./ storage)	+ 80 °C
Min. permissible ambient motor temp. (transp./storage)	- 40 °C
Mounting position	Any
Condensate discharge holes	None, open rotor
Operation mode	S1
Motor bearing	Ball bearing
Touch current acc. IEC 60990 (measuring network Fig. 4, TN system)	< 0.75 mA
Electrical leads	With plug
Motor protection	Thermal overload protector (TOP) brought out
Cable exit	Axial
Protection class	I (if protective earth is connected by customer)
Product conforming to standard	EN 60335-1; CE
Approval	CCC; CSA C22.2 Nr.100; UL 1004-1

AC centrifugal fan

forward curved, dual inlet
with housing and angle bracket

Product drawing

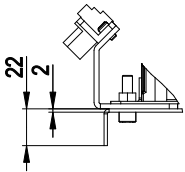
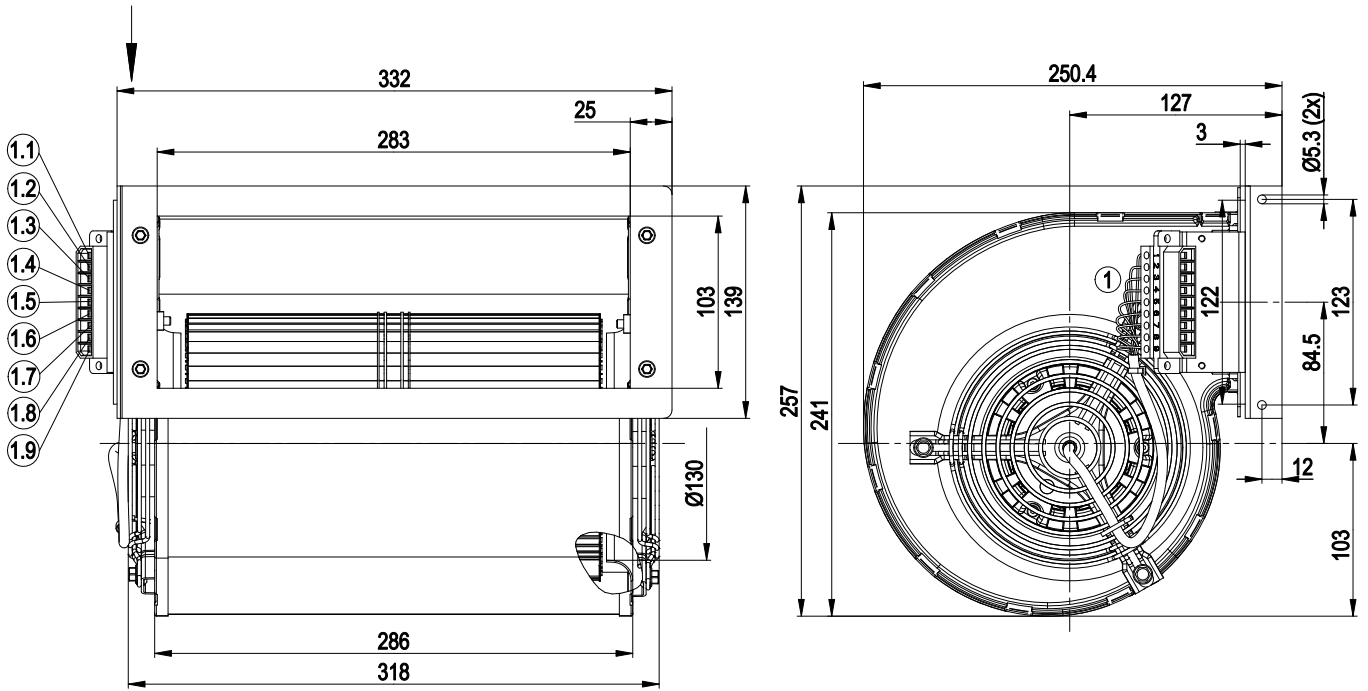

1	9-pole Weidmüller strip 1612160000
1.1	black
1.2	blue
1.3	brown
1.4	grey (TOP)
1.5	FE (green/yellow)
1.6	grey (TOP)
1.7	green
1.8	white
1.9	yellow

AC centrifugal fan

forward curved, dual inlet
with housing and angle bracket

Connection screen

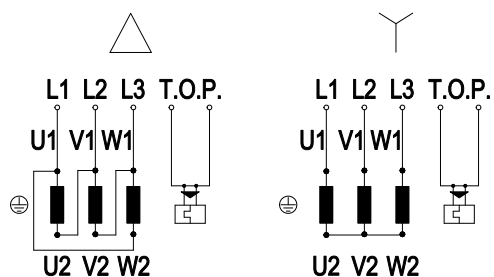

Note: Direction of rotation changes when two phases are reversed

Δ	Delta-connection	Y	Star connection	L1	black
L2	blue	L3	brown	U1	black
V1	blue	W1	brown	U2	green
V2	white	W2	yellow	TOP	grey

AC centrifugal fan

forward curved, dual inlet
with housing and angle bracket

Charts: Air flow 50 Hz

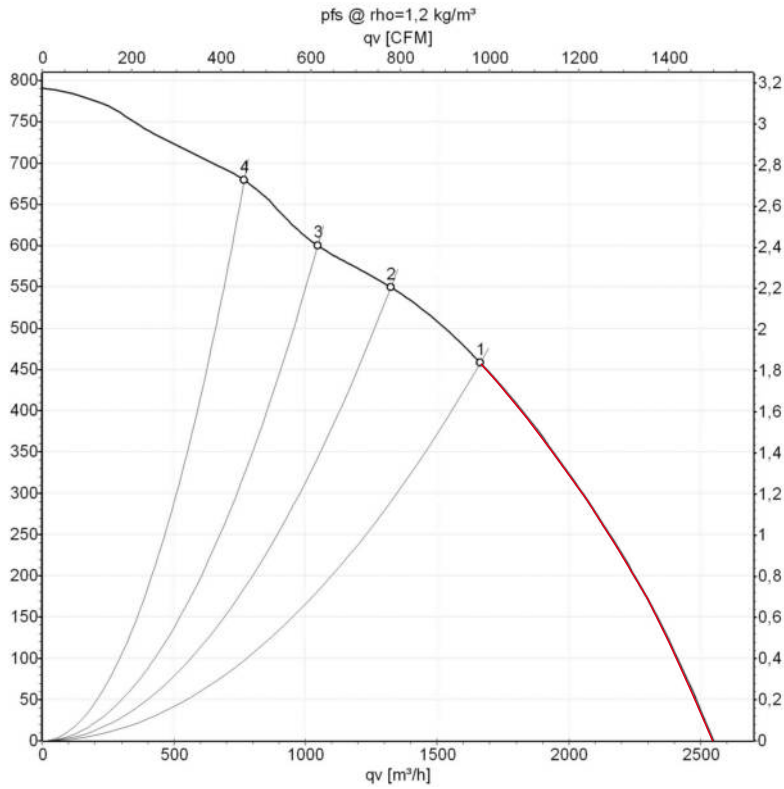

Air performance measured as per ISO 5801 Installation category A. For detailed information on the measuring set-up, please contact ebm-papst. Suction-side noise levels: LwA measured as per ISO 13347 / LpA measured with 1m distance to fan axis. The values given are valid under the measuring conditions mentioned above and may vary according to the actual installation situation. With any deviation from the standard set-up, the specific values have to be checked and reviewed with the unit installed.

Measured values

	Conn.	U	f	n	P _e	I	qv	p _{fs}
		V	Hz	min ⁻¹	W	A	m ³ /h	Pa
1	Y	400	50	2700	700	1.10	1660	460
2	Y	400	50	2775	562	0.97	1320	550
3	Y	400	50	2815	482	0.87	1045	600
4	Y	400	50	2840	428	0.81	765	680

Conn. = Connection · U = Supply voltage · f = Frequency · n = Speed · P_e = Power input · I = Current draw · qv = Air flow · p_{fs} = Pressure increase



AC centrifugal fan

forward curved, dual inlet
with housing and angle bracket

Charts: Air flow 60 Hz

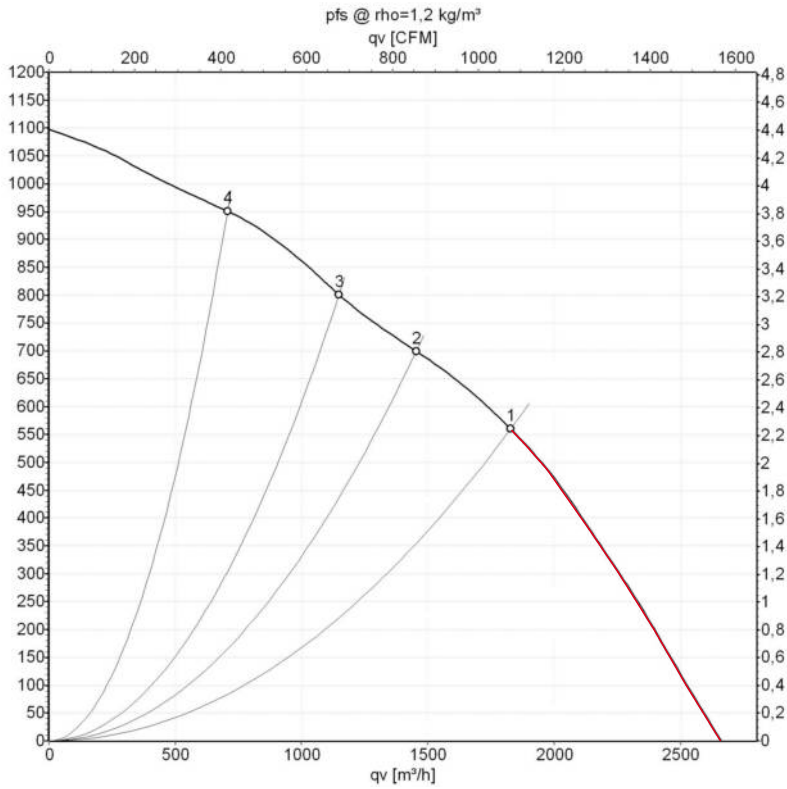

Air performance measured as per ISO 5801 Installation category A. For detailed information on the measuring set-up, please contact ebmpapst. Suction-side noise levels: LwA measured as per ISO 13347 / LpA measured with 1m distance to fan axis. The values given are valid under the measuring conditions mentioned above and may vary according to the actual installation situation. With any deviation from the standard set-up, the specific values have to be checked and reviewed with the unit installed.

Measured values

	Conn.	U	f	n	P _e	I	qv	p _{fs}
		V	Hz	min ⁻¹	W	A	m ³ /h	Pa
1	Y	400	60	2960	1055	1.63	1830	560
2	Y	400	60	3120	871	1.35	1465	700
3	Y	400	60	3210	737	1.16	1145	800
4	Y	400	60	3300	592	0.95	710	950

Conn. = Connection · U = Supply voltage · f = Frequency · n = Speed · P_e = Power input · I = Current draw · qv = Air flow · p_{fs} = Pressure increase

