

D2D133-AB06-31

AC centrifugal fan

forward curved, dual inlet
with housing (flange)

ASIA PACIFIC SHENGRUI LIMITED

Phone +00852 56261528

info@apacfan.com

www.apacfan.com

Nominal data

Type	D2D133-AB06-31		
Motor	M2D068-DF		
Phase		3~	3~
Nominal voltage	VAC	400	400
Nominal voltage range	VAC	360 .. 480	360 .. 480
Connection		Y	Y
Frequency	Hz	50	60
Type of data definition		cs	cs
Valid for approval / standard		CE	CE
Speed	min ⁻¹	2500	2600
Power input	W	120	165
Current draw	A	0.2	0.25
Min. back pressure	Pa	250	275
Min. ambient temperature	°C	-25	-25
Max. ambient temperature	°C	-	-

ml = Max. load · me = Max. efficiency · fa = Running at free air · cs = Customer specs · cu = Customer unit
Subject to alterations



AC centrifugal fan

forward curved, dual inlet
with housing (flange)

Technical features

Mass	3.9 kg
Size	133 mm
Surface of rotor	Uncoated
Material of impeller	Sheet steel, hot-galvanised
Housing material	Sheet steel, hot-galvanised
Material of guard grille	Steel, phosphated and plastic-coated in white aluminium (RAL 9006)
Direction of rotation	Counter-clockwise, seen on rotor
Type of protection	IP 44; Depending on installation and position
Insulation class	"F"
Humidity class	F1-1
Max. permissible ambient motor temp. (transp./ storage)	+ 80 °C
Min. permissible ambient motor temp. (transp./storage)	- 40 °C
Mounting position	Any
Condensate discharge holes	None
Operation mode	S1
Motor bearing	Ball bearing
Touch current acc. IEC 60990 (measuring network Fig. 4, TN system)	< 0.75 mA
Cable exit	Axial
Protection class	I (if protective earth is connected by customer)
Product conforming to standard	EN 60335-1, motor does not have factory-installed overheating protection; CE
Approval	EAC; UL 1004-1; CSA C22.2 Nr.100

D2D133-AB06-31

AC centrifugal fan

forward curved, dual inlet
with housing (flange)

Product drawing

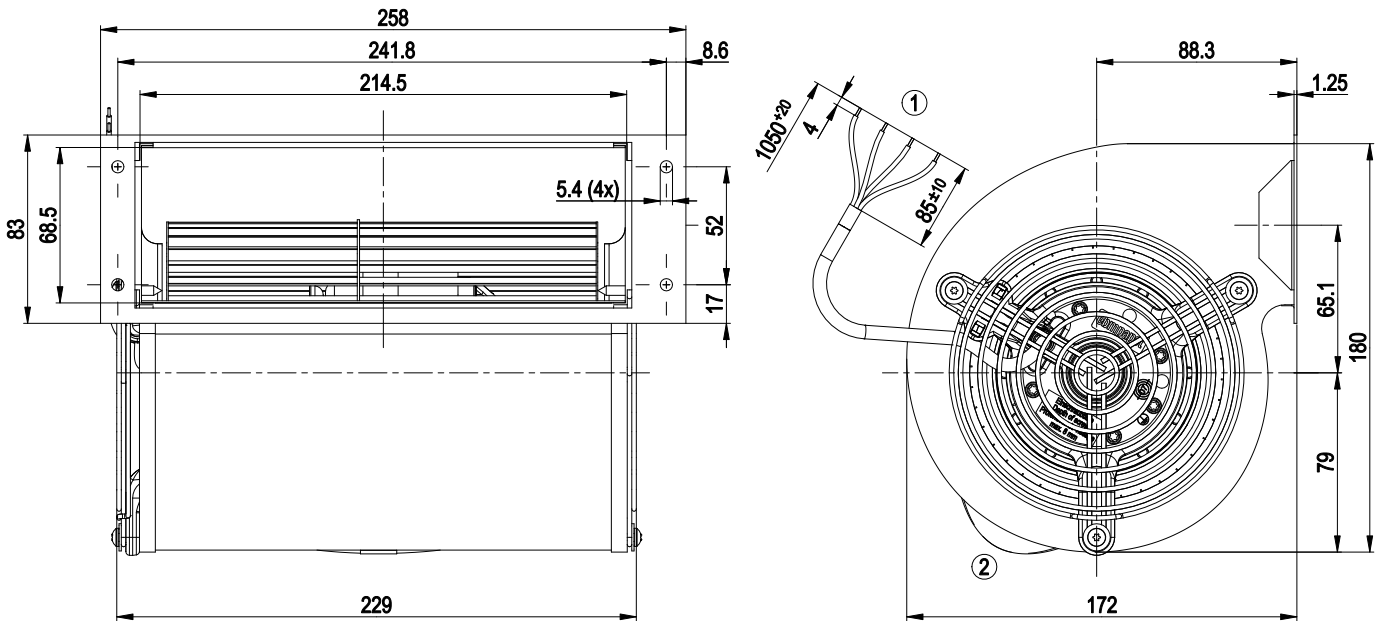

- | | |
|---|---|
| 1 | Connection line PFA 1x AWG18, 3x AWG20, without shouldered parts |
| 2 | Enclosed in loose form: 1x connector housing AMP 350779-4, 4x female terminal AMP 926884-1, 1x connector housing AMP 350780-1, 3x plug pin AMP 926885-1, 1x plug pin AMP 350654-1 |



AC centrifugal fan

forward curved, dual inlet
with housing (flange)

Connection screen

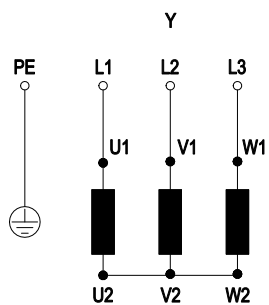

Change direction of rotation by reversing two phases

PE	green/yellow	L1	black	L2	blue
L3	brown	Y	Star connection		

AC centrifugal fan

forward curved, dual inlet
with housing (flange)

Charts: Air flow 50 Hz

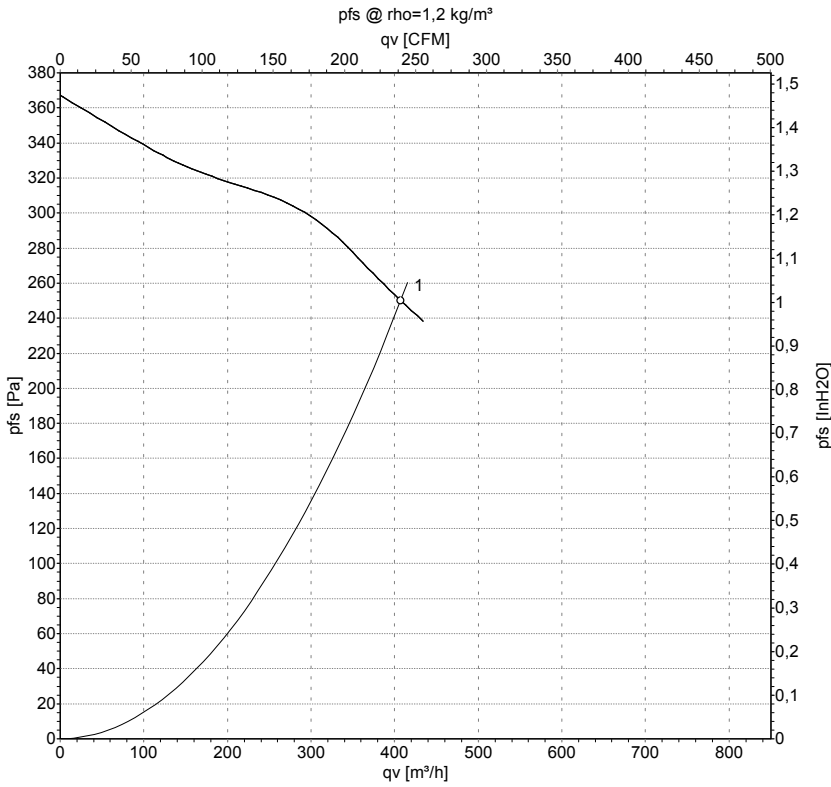

Measurement: LU-21953

Air performance measured as per ISO 5801 Installation category A. For detailed information on the measuring set-up, please contact ebm-papst. Suction-side noise levels: L_{wA} measured as per ISO 13347 / L_{pA} measured with 1m distance to fan axis. The values given are valid under the measuring conditions mentioned above and may vary according to the actual installation situation. With any deviation from the standard set-up, the specific values have to be checked and reviewed with the unit installed.

Measured values

	U	f	n	P _e	I	q _v	p _{fs}
	V	Hz	min ⁻¹	W	A	m ³ /h	Pa
1	400	50	2500	120	0.20	405	250

U = Supply voltage · f = Frequency · n = Speed · P_e = Power input · I = Current draw · q_v = Air flow · p_{fs} = Pressure increase



AC centrifugal fan

forward curved, dual inlet

with housing (flange)

Charts: Air flow 60 Hz

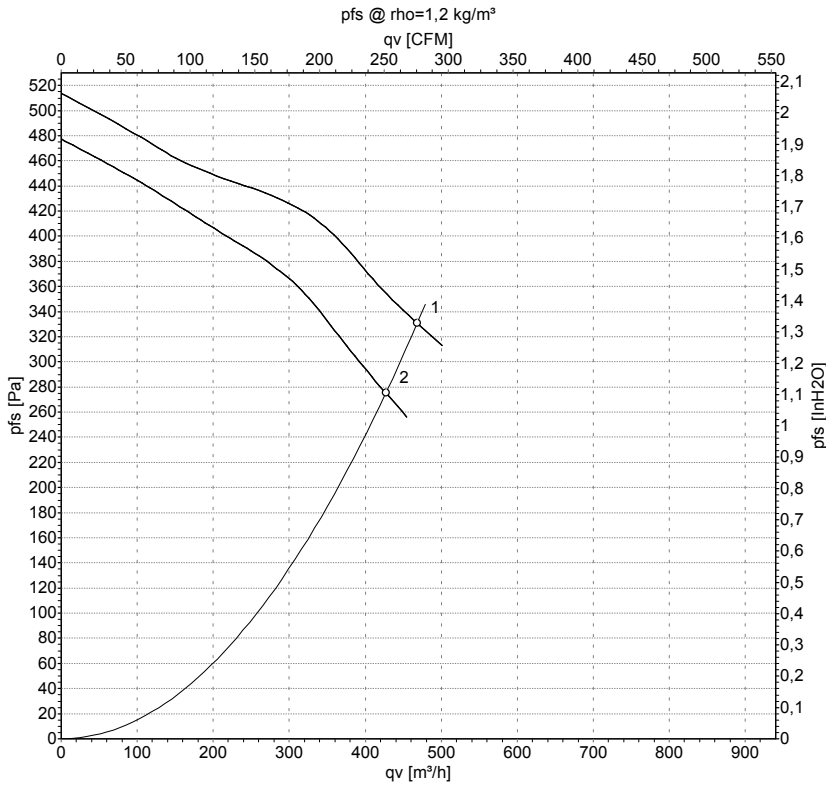

Measurement: LU-21955
Measurement: LU-21954

Air performance measured as per ISO 5801 Installation category A. For detailed information on the measuring set-up, please contact ebm-papst. Suction-side noise levels: LwA measured as per ISO 13347 / LpA measured with 1m distance to fan axis. The values given are valid under the measuring conditions mentioned above and may vary according to the actual installation situation. With any deviation from the standard set-up, the specific values have to be checked and reviewed with the unit installed.

Measured values

	U	f	n	P _e	I	qv	p _{fs}
	V	Hz	min ⁻¹	W	A	m³/h	Pa
1	480	60	2850	195	0.25	470	330
2	400	60	2600	165	0.25	425	275

U = Supply voltage · f = Frequency · n = Speed · P_e = Power input · I = Current draw · qv = Air flow · p_{fs} = Pressure increase

