

A6D910-AA01-01

AC axial fan - HyBlade®

sickled blades (S series)

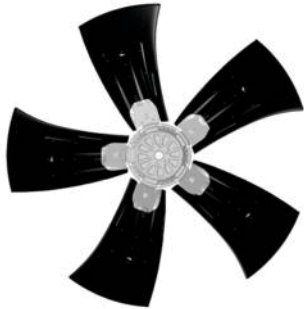

ASIA PACIFIC SHENGRUI LIMITED

Phone +00852 56261528

info@apacfan.com

www.apacfan.com

Limited partnership · Headquarters Mulfingen
County court Stuttgart · HRA 590344

General partner Elektrobau Mulfingen GmbH · Headquarters Mulfingen
County court Stuttgart · HRB 590142



Nominal data

Type	A6D910-AA01-01		
Motor	M6D138-NA		
Phase		3~	3~
Nominal voltage	VAC	400	400
Connection		Δ	Y
Frequency	Hz	50	50
Type of data definition		ml	ml
Valid for approval / standard		CE	CE
Speed	min ⁻¹	885	685
Power input	W	2480	1570
Current draw	A	5.15	2.9
Max. back pressure	Pa	150	90
Min. ambient temperature	°C	-40	-40
Max. ambient temperature	°C	50	50
Starting current	A	18.6	6.2

ml = max. load · me = max. efficiency · fa = running at free air · cs = customer specs · cu = customer unit
Subject to alterations

Data according to ErP directive

Installation category	A
Efficiency category	Static
Variable speed drive	No
Specific ratio*	1.00

* Specific ratio = $1 + p_{fs} / 100\,000\text{ Pa}$

	Actual	Request 2013	Request 2015
Overall efficiency η_{es}	36.1	32.1	36.1
Efficiency grade N	40	36	40
Power input P_e	kW	2.46	
Air flow q_v	m ³ /h	21770	
Pressure increase p_{fs}	Pa	142	
Speed n	min ⁻¹	890	

Data established at point of optimum efficiency



ebmpapst

A6D910-AA01-01

AC axial fan - HyBlade®

sickled blades (S series)

Technical features

Mass	27.8 kg
Size	910 mm
Surface of rotor	Cast in aluminium
Material of terminal box	PP plastic
Material of blades	Aluminium sheet insert, sprayed with PP plastic
Number of blades	5
Blade angle	0°
Direction of air flow	"V"
Direction of rotation	Clockwise, seen on rotor
Type of protection	IP 54
Insulation class	"F"
Humidity class	F3-1
Max. permissible ambient motor temp. (transp./ storage)	+80 °C
Min. permissible ambient motor temp. (transp./storage)	-40 °C
Mounting position	Any
Condensate discharge holes	On rotor and stator sides
Operation mode	S1
Motor bearing	Ball bearing
Touch current acc. IEC 60990 (measuring network Fig. 4, TN system)	<= 3.5 mA
Electrical leads	Via terminal box
Motor protection	Thermal overload protector (TOP) brought out
Cable exit	Axial
Protection class	I (if protective earth is connected by customer)
Product conforming to standard	EN 60034; EN 61800-5-1; CE
Approval	VDE



Product drawing

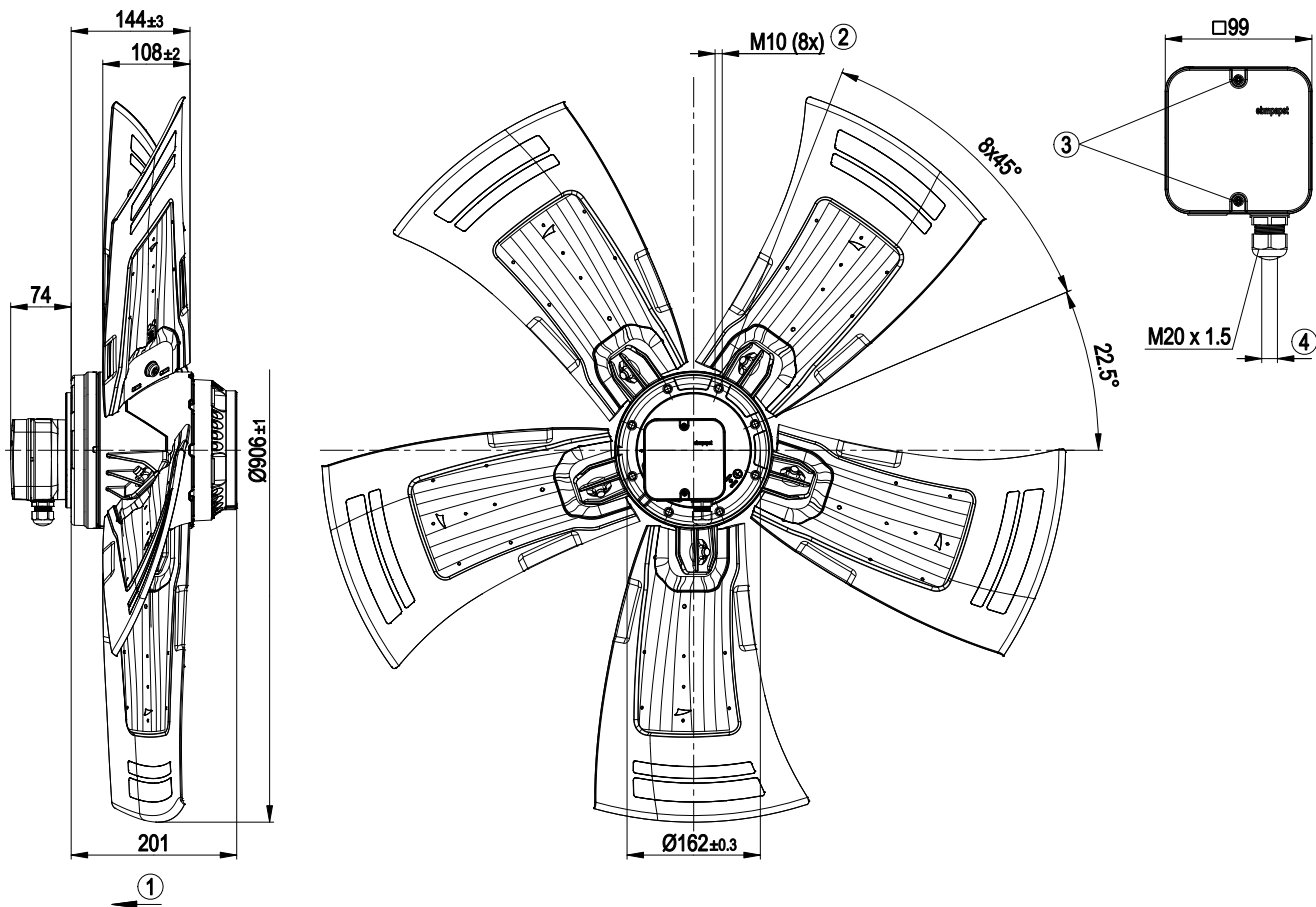

1	Direction of air flow "V"
2	Depth of screw max. 18 mm
3	Tightening torque 1.5±0.2 Nm
4	Cable diameter: min. 7 mm, max. 14 mm; tightening torque: 2±0.3 Nm

Connection screen

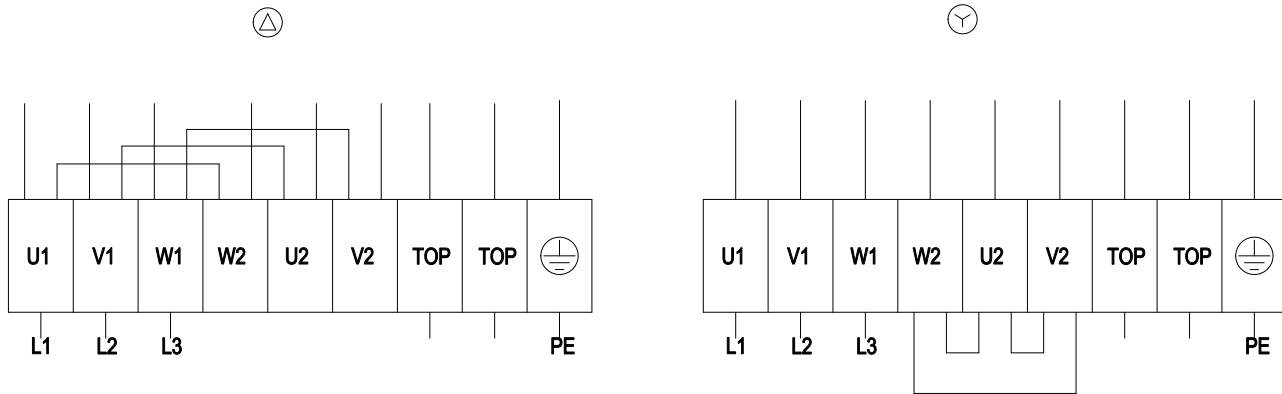

Δ	Delta connection	Y	Star connection	L1	= U1 = black
L2	= V1 = blue	L3	= W1 = brown	W2	yellow
U2	green	V2	white	TOP	2 x grey
PE	green/yellow				

Charts: Air flow 50 Hz

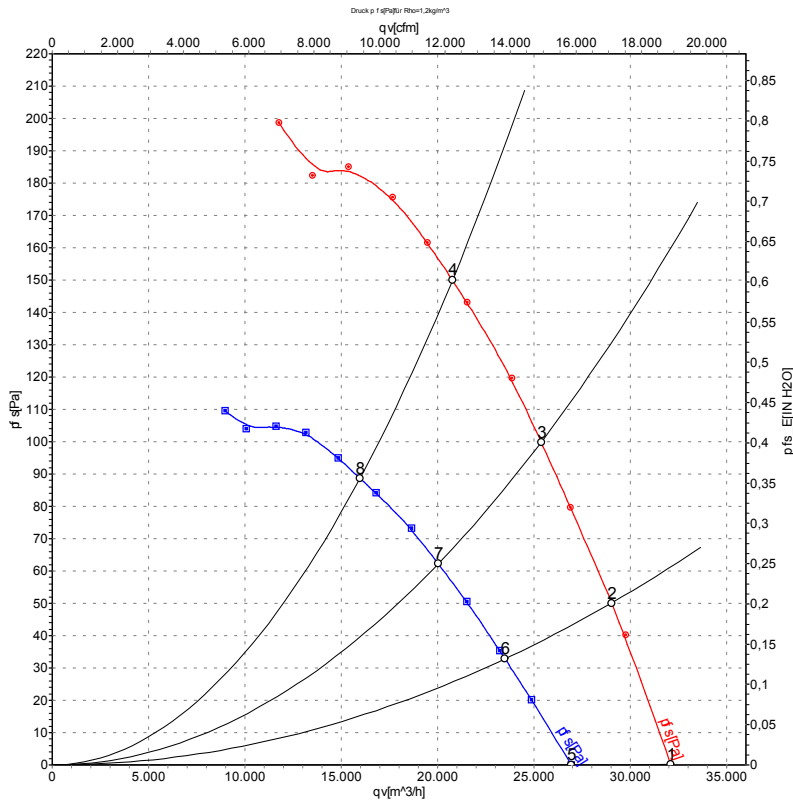

Measurement: LU-117504
Measurement: LU-118398

Air performance measured as per ISO 5801 Installation category A. For detailed information on the measuring set-up, please contact ebm-papst. Suction-side noise levels: LwA measured as per ISO 13347 / LpA measured with 1m distance to fan axis. The values given are valid under the measuring conditions mentioned above and may vary according to the actual installation situation. With any deviation from the standard set-up, the specific values have to be checked and reviewed with the unit installed.

Measured values

	Conn.	U	f	n	P _e	I	LpA _{in}	LwA _{in}	LwA _{out}	qv	p _{fs}
		V	Hz	min ⁻¹	W	A	dB(A)	dB(A)	dB(A)	m ³ /h	Pa
1	Δ	400	50	930	1786	4.38	70	77	78	32100	0
2	Δ	400	50	915	2050	4.67	68	75	75	29020	50
3	Δ	400	50	900	2262	4.88	68	75	75	25370	100
4	Δ	400	50	885	2480	5.15	70	77	77	20770	150
5	Y	400	50	785	1291	2.44	65	73	73	26940	0
6	Y	400	50	750	1410	2.67	63	70	70	23500	33
7	Y	400	50	715	1489	2.82	61	69	69	20030	62
8	Y	400	50	685	1570	2.90	63	71	70	15980	90

Conn. = Connection · U = Supply voltage · f = Frequency · n = Speed · P_e = Power input · I = Current draw · LpA_{in} = Sound pressure level inlet side · LwA_{in} = Sound power level inlet side · LwA_{out} = Sound power level outlet side · qv = Air flow · p_{fs} = Pressure increase

