

ASIA PACIFIC SHENGRUI LIMITED

Phone +00852 56261528

info@apacfan.com

www.apacfan.com



Nominal data

Type	A4E330-AP18-13		
Motor	M4E068-DF		
Phase		1~	1~
Nominal voltage	VAC	230	230
Frequency	Hz	50	60
Type of data definition		fa	fa
State		prelim.	prelim.
Valid for approval / standard		CE	CE
Speed	min ⁻¹	1390	1600
Power input	W	120	140
Current draw	A	0.57	0.61
Motor capacitor	μF	4	4
Capacitor voltage	VDB	400	400
Max. back pressure	Pa	90	75
Max. ambient temperature	°C	40	40
Starting current	A	1.4	1.3

ml = max. load · me = max. efficiency · fa = running at free air · cs = customer specs · cu = customer unit
Subject to alterations

Data according to ErP directive

Installation category	A
Efficiency category	Static
Variable speed drive	No
Specific ratio*	1.00

* Specific ratio = $1 + p_g / 100\,000\text{ Pa}$

	Actual	Request 2013	Request 2015
Overall efficiency η_{es}	24.7	24.1	28.1
Efficiency grade N	36.6	36	40
Power input P_e	kW	0.13	
Air flow q_v	m ³ /h	1950	
Pressure increase p_{fs}	Pa	62	
Speed n	min ⁻¹	1345	

Data established at point of optimum efficiency



AC axial fan

sickled blades (S series)

Technical features

Mass	2.6 kg
Size	330 mm
Surface of rotor	Coated in black
Material of blades	Sheet steel, coated in black
Number of blades	5
Direction of air flow	"V"
Direction of rotation	Counter-clockwise, seen on rotor
Type of protection	IP 44; Depending on installation and position as per EN 60034-5
Insulation class	"B"
Humidity class	F1-2
Max. permissible ambient motor temp. (transp./ storage)	+ 80 °C
Min. permissible ambient motor temp. (transp./storage)	- 40 °C
Mounting position	Any
Condensate discharge holes	Rotor-side
Operation mode	S1
Motor bearing	Ball bearing
Touch current acc. IEC 60990 (measuring network Fig. 4, TN system)	< 0.75 mA
Motor protection	Thermal overload protector (TOP) wired internally
Cable exit	Axial
Protection class	I (if protective earth is connected by customer)
Product conforming to standard	EN 60335-1; CE
Approval	CCC; UL 2111; CSA C22.2 Nr.77

Product drawing

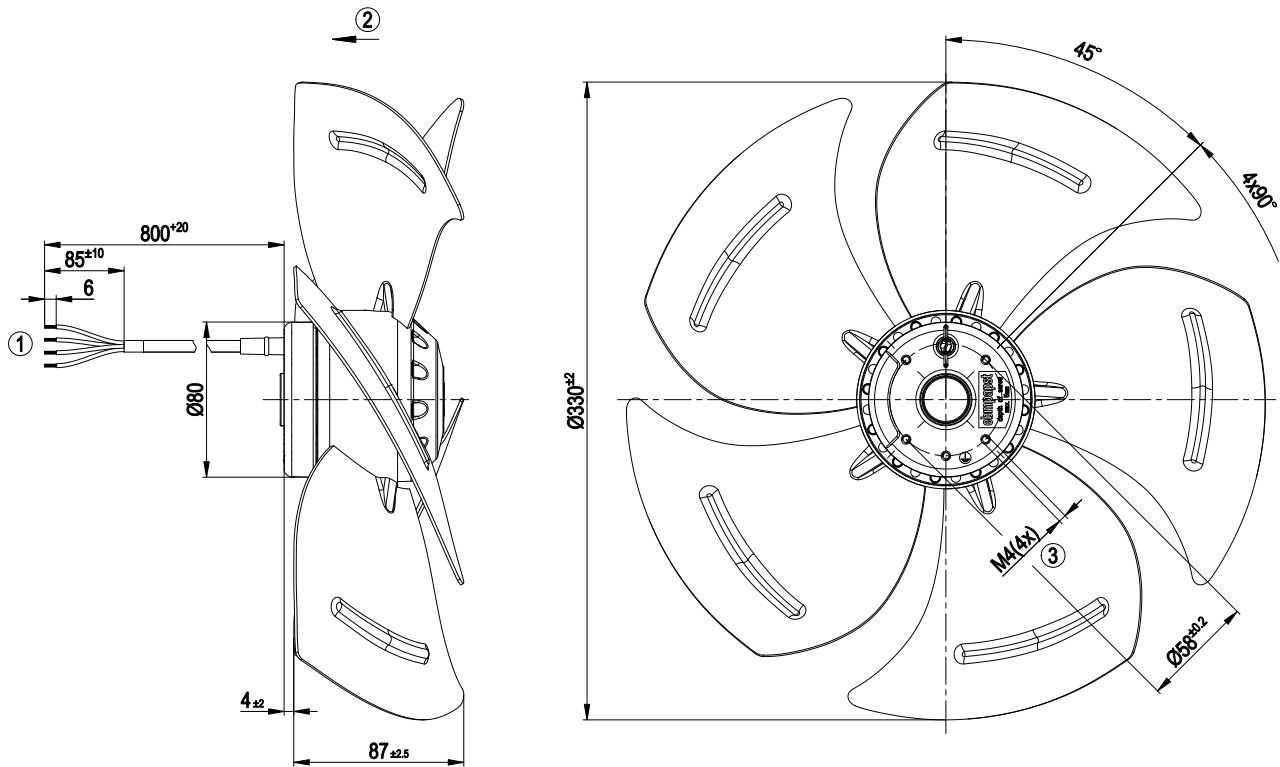

1	Connection line PVC 4G 0.5mm ² , 4x brass lead tips crimped
2	Direction of air flow "V"
3	Depth of screw max. 5 mm

Connection screen

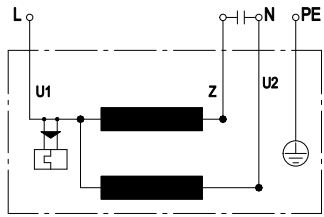

U1	blue	Z	brown	U2	black
PE	green/yellow				

Charts: Air flow 50 Hz

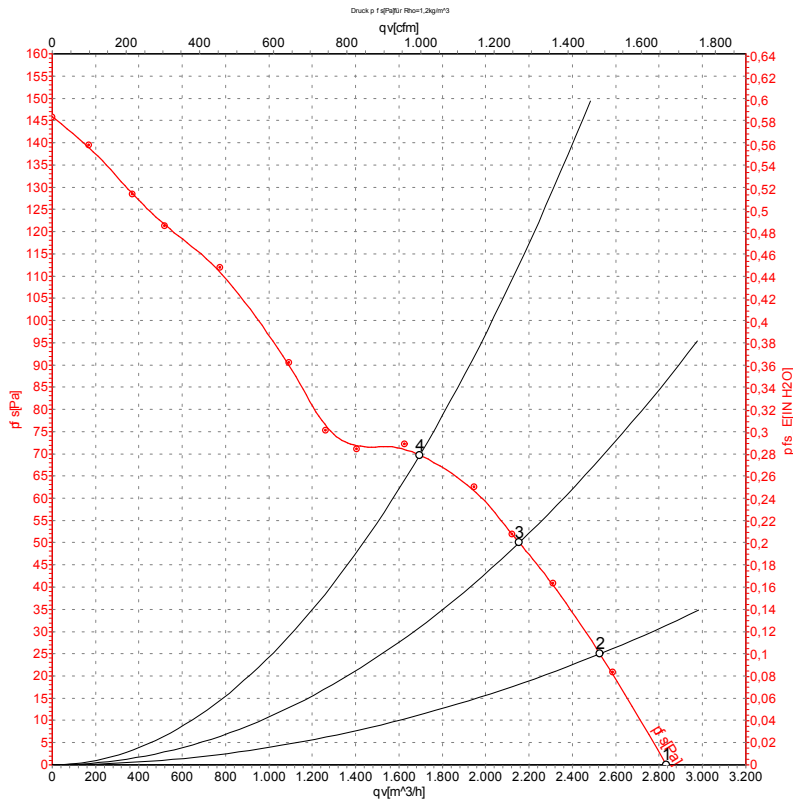

Measurement: LU-32943

Air performance measured as per ISO 5801 Installation category A. For detailed information on the measuring set-up, please contact ebm-papst. Suction-side noise levels: L_{wA} measured as per ISO 13347 / L_{pA} measured with 1m distance to fan axis. The values given are valid under the measuring conditions mentioned above and may vary according to the actual installation situation. With any deviation from the standard set-up, the specific values have to be checked and reviewed with the unit installed.

Measured values

	U	f	n	P _e	I	qv	p _{fs}
	V	Hz	min ⁻¹	W	A	m ³ /h	Pa
1	230	50	1390	120	0.57	2835	0
2	230	50	1375	122	0.58	2525	25
3	230	50	1355	130	0.61	2155	50
4	230	50	1330	140	0.64	1695	70

U = Supply voltage · f = Frequency · n = Speed · P_e = Power input · I = Current draw · qv = Air flow · p_{fs} = Pressure increase



Charts: Air flow 60 Hz

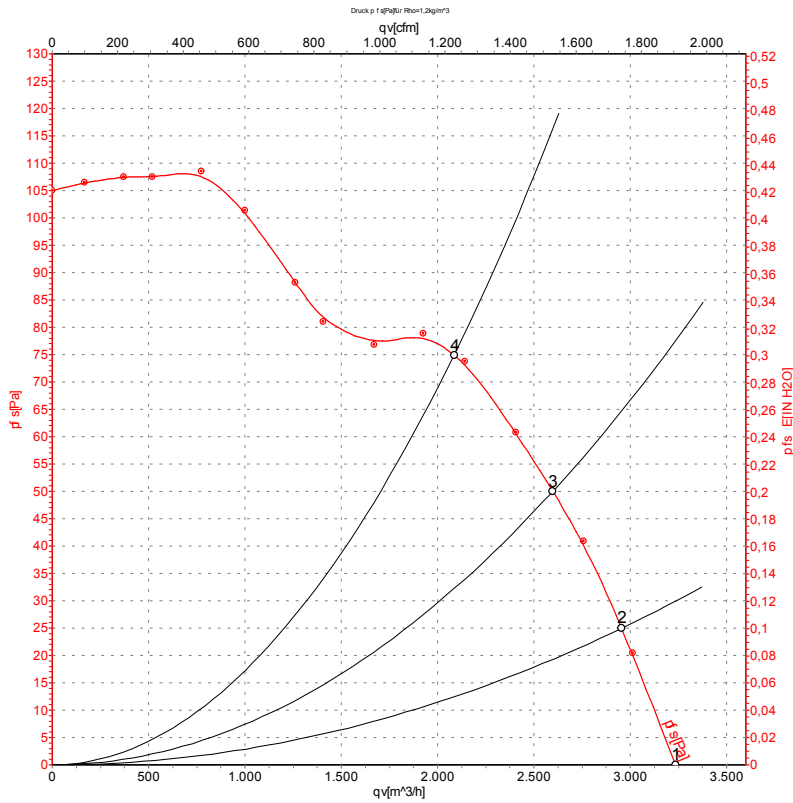

Measurement: LU-32944

Air performance measured as per ISO 5801 Installation category A. For detailed information on the measuring set-up, please contact ebm-papst. Suction-side noise levels: LwA measured as per ISO 13347 / LpA measured with 1m distance to fan axis. The values given are valid under the measuring conditions mentioned above and may vary according to the actual installation situation. With any deviation from the standard set-up, the specific values have to be checked and reviewed with the unit installed.

Measured values

	U	f	n	Pe	I	qv	Pfs
	V	Hz	min ⁻¹	W	A	m ³ /h	Pa
1	230	60	1600	140	0.61	3235	0
2	230	60	1575	150	0.65	2955	25
3	230	60	1530	163	0.71	2600	50
4	230	60	1470	179	0.78	2085	75

U = Supply voltage · f = Frequency · n = Speed · Pe = Power input · I = Current draw · qv = Air flow · Pfs = Pressure increase

