

ASIA PACIFIC SHENGRUI LIMITED

Phone +00852 56261528

info@apacfan.com

www.apacfan.com

Nominal data

Type	A2S130-AB03-11		
Motor	M2S052-CA		
Phase		1~	1~
Nominal voltage	VAC	230	230
Nominal voltage range	VAC	220 .. 240	
Frequency	Hz	50	60
Method of obtaining data		fa	fa
Valid for approval/standard		CE	UL
Speed (rpm)	min ⁻¹	2800	3250
Power consumption	W	50	44
Current draw	A	0.3	-
Min. ambient temperature	°C	-25	-25
Max. ambient temperature	°C	-	60
Starting current	A		0.40

ml = Max. load · me = Max. efficiency · fa = Free air · cs = Customer specification · ce = Customer equipment
Subject to change



Technical description

Weight	0.9 kg
Fan size	130 mm
Rotor surface	Painted black
Blade material	Sheet steel, painted black
Number of blades	7
Airflow direction	"V"
Direction of rotation	Counterclockwise, viewed toward rotor
Degree of protection	IP44
Insulation class	"B"
Max. permitted ambient temp. for motor (transport/storage)	+ 80 °C
Min. permitted ambient temp. for motor (transport/storage)	- 40 °C
Installation position	Any
Condensation drainage holes	None
Mode	S1
Motor bearing	Ball bearing
Touch current according to IEC 60990 (measuring circuit Fig. 4, TN system)	< 0.75 mA
Motor protection	Thermal overload protector (TOP) internally connected
With cable	Variable
Protection class	I (with customer connection of protective earth)
Conformity with standards	EN 60335-1; CE
Approval	UL 1004-1; CCC; EAC; CSA C22.2 No. 100

Product drawing

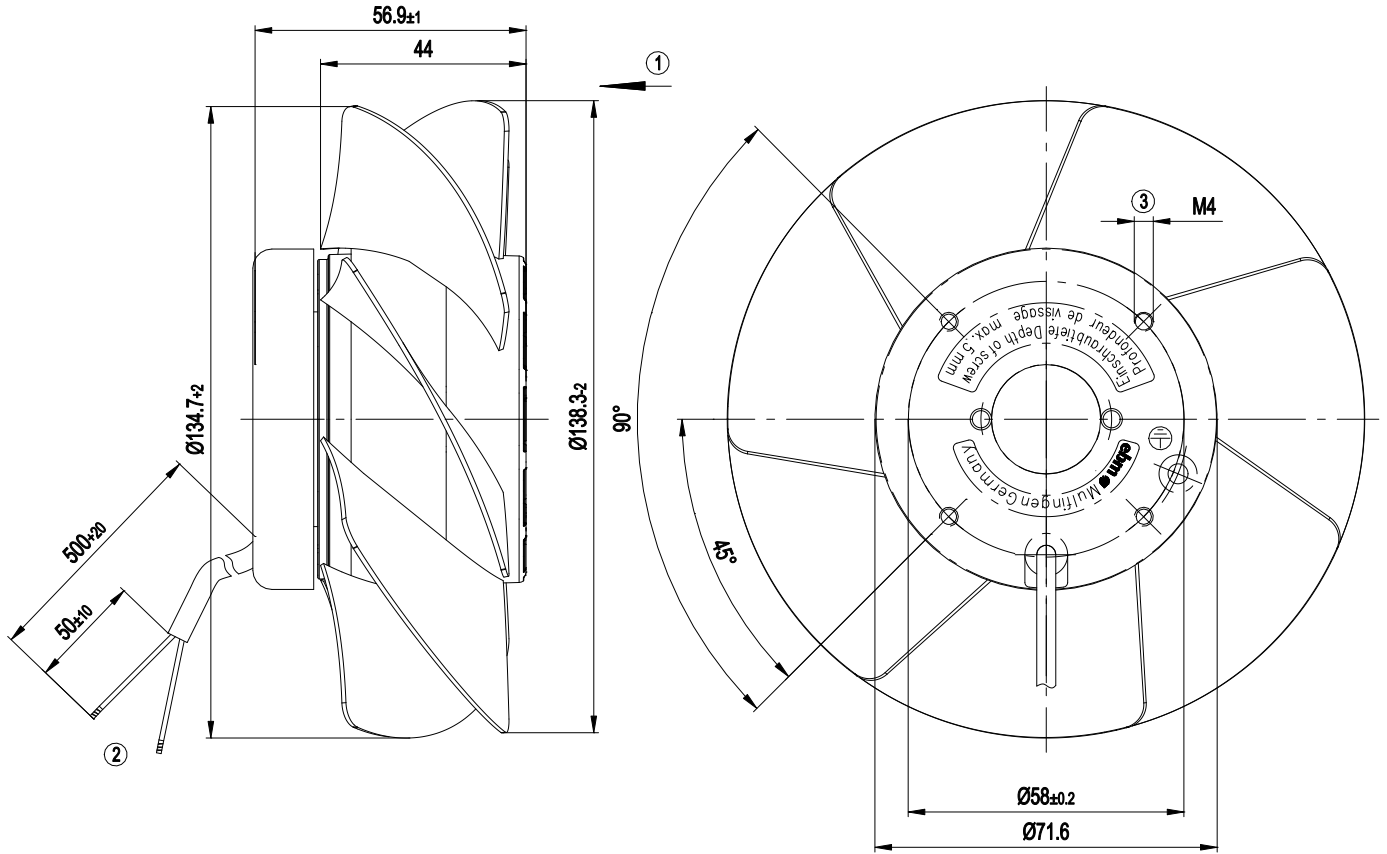

1	Direction of air flow "V"
2	Cable AWG 20, 2x crimped ferrules
3	Max. clearance for screw 5 mm

Connection diagram

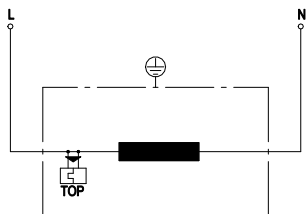

L	= black
N	= black
TOP	= thermal overload protector

Curves: Air performance 50 Hz

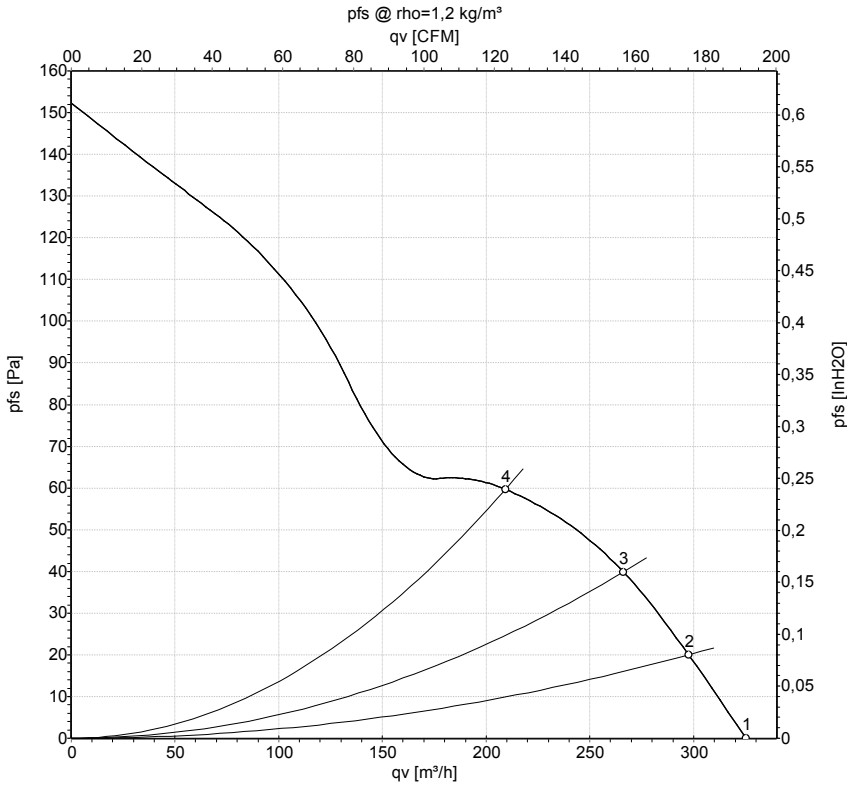

Measurement: LU-11003-1

Air performance measured according to ISO 5801 installation category A. For detailed information on the measurement setup, contact ebm-papst. Intake sound level: Sound power level according to ISO 13347 / sound pressure level measured at 1 m distance from fan axis. The values given are valid under the specified measuring conditions and may vary due to conditions of installation. For deviations from the standard configuration, the parameters have to be checked on the installed unit.

Measured values

	U	f	n	P _e	I	qv	p _{fs}	qv	p _{fs}
	V	Hz	min ⁻¹	W	A	m ³ /h	Pa	CFM	inH ₂ O
1	240	50	2800	50	0.30	325	0	190	0.00
2	240	50	2790	50	0.30	300	20	175	0.08
3	240	50	2775	50	0.30	265	40	155	0.16
4	240	50	2760	50	0.30	210	60	125	0.24

U = Power supply · f = Frequency · n = Speed (rpm) · P_e = Power consumption · I = Current draw · qv = Air flow · p_{fs} = Pressure increase



Curves: Air performance 60 Hz

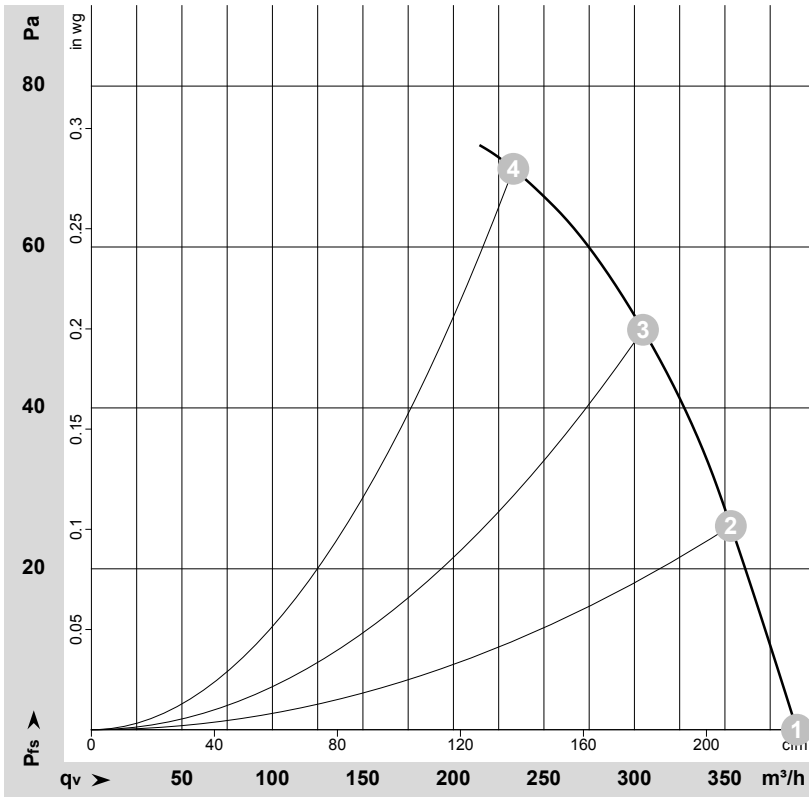

$\rho = 1.15 \text{ kg/m}^3 \pm 2 \%$

Measurement: LU-58476-1

Air performance measured according to ISO 5801 installation category A. For detailed information on the measurement setup, contact ebm-papst. Intake sound level: Sound power level according to ISO 13347 / sound pressure level measured at 1 m distance from fan axis. The values given are valid under the specified measuring conditions and may vary due to conditions of installation. For deviations from the standard configuration, the parameters have to be checked on the installed unit.

Measured values

	U	f	n	P _e	I	q _v	p _{fs}	q _v	p _{fs}
	V	Hz	min ⁻¹	W	A	m ³ /h	Pa	CFM	inH ₂ O
1	230	60	3250	39	0.25	390	0	230	0.00
2	230	60	3200	42	0.25	355	25	210	0.10
3	230	60	3165	43	0.26	305	50	180	0.20
4	230	60	3145	44	0.26	235	70	135	0.28

U = Power supply · f = Frequency · n = Speed (rpm) · P_e = Power consumption · I = Current draw · q_v = Air flow · p_{fs} = Pressure increase