

# AC axial fan

straight blades (A series)

**ASIA PACIFIC SHENGRUI LIMITED**  
 Phone +00852 56261528  
 info@apacfan.com  
 www.apacfan.com



## Nominal data

Type	A2D250-AA02-01		
Motor	M2D068-DF		
Phase		3~	3~
Nominal voltage	VAC	400	400
Connection		Y	Y
Frequency	Hz	50	60
Type of data definition		fa	fa
Valid for approval / standard		CE	CE
Speed	min <sup>-1</sup>	2650	2950
Power input	W	110	160
Current draw	A	0.22	0.26
Max. back pressure	Pa	205	300
Max. ambient temperature	°C	70	40

ml = max. load · me = max. efficiency · fa = running at free air · cs = customer specs · cu = customer unit  
 Subject to alterations

## Data according to ErP directive

Installation category	A	Overall efficiency $\eta_{es}$	Actual	Request 2013	Request 2015
Efficiency category	Static	Efficiency grade N	28.1	24.1	28.1
Variable speed drive	No	Power input $P_e$	40	36	40
Specific ratio*	1.00	Power input $P_e$	kW	0.13	
		Air flow $q_v$	m <sup>3</sup> /h	1050	
		Pressure increase $p_{fs}$	Pa	121	
		Speed n	min <sup>-1</sup>	2600	

Data established at point of optimum efficiency



# AC axial fan

straight blades (A series)

## Technical features

<b>Mass</b>	2.05 kg
<b>Size</b>	250 mm
<b>Surface of rotor</b>	Coated in black
<b>Material of impeller</b>	Sheet steel, coated in black
<b>Number of blades</b>	5
<b>Direction of air flow</b>	"V"
<b>Direction of rotation</b>	Counter-clockwise, seen on rotor
<b>Type of protection</b>	IP 44
<b>Insulation class</b>	"B"
<b>Humidity class</b>	F1-2
<b>Max. permissible ambient motor temp. (transp./ storage)</b>	+ 80 °C
<b>Min. permissible ambient motor temp. (transp./storage)</b>	- 40 °C
<b>Mounting position</b>	Shaft horizontal or rotor on bottom; rotor on top on request
<b>Condensate discharge holes</b>	Rotor-side
<b>Operation mode</b>	S1
<b>Motor bearing</b>	Ball bearing
<b>Touch current acc. IEC 60990 (measuring network Fig. 4, TN system)</b>	< 0.75 mA
<b>Cable exit</b>	Lateral
<b>Protection class</b>	I (if protective earth is connected by customer)
<b>Product conforming to standard</b>	EN 60335-1
<b>Approval</b>	CCC

Product drawing

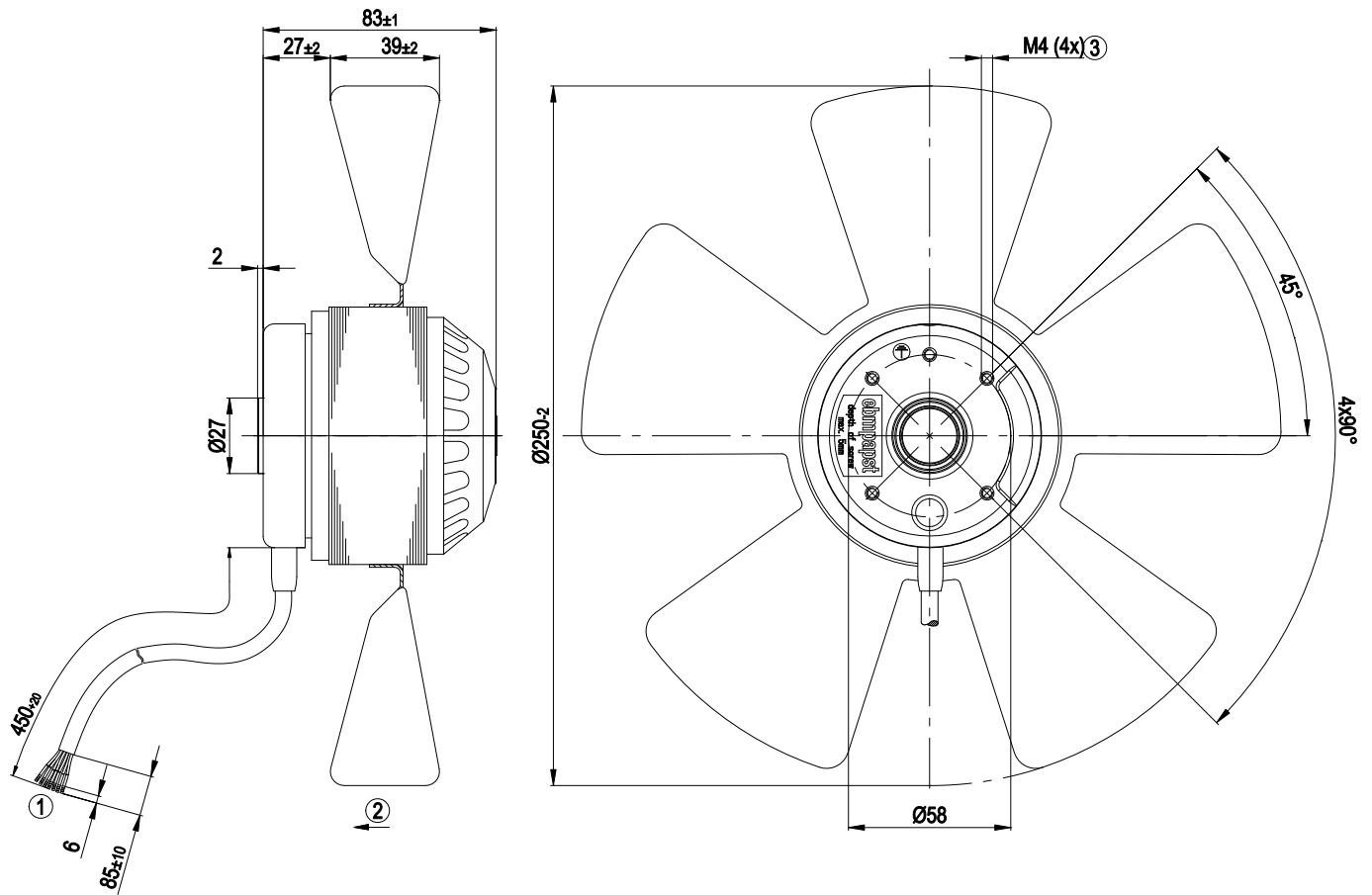

1	Connection line PVC 7 x 0.5 mm <sup>2</sup> ; 7 x brass lead tips crimped
2	Direction of air flow "V"
3	Depth of screw max. 5 mm

## Connection screen

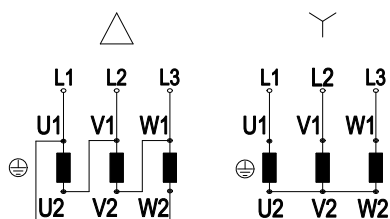

Note: Direction of rotation changes when two phases are reversed

Δ	Delta connection	Y	Star connection	L1	black
L2	blue	L3	brown	U1	black
V1	blue	W1	brown	U2	green
V2	white	W2	yellow		

## Charts: Air flow 50 Hz Y

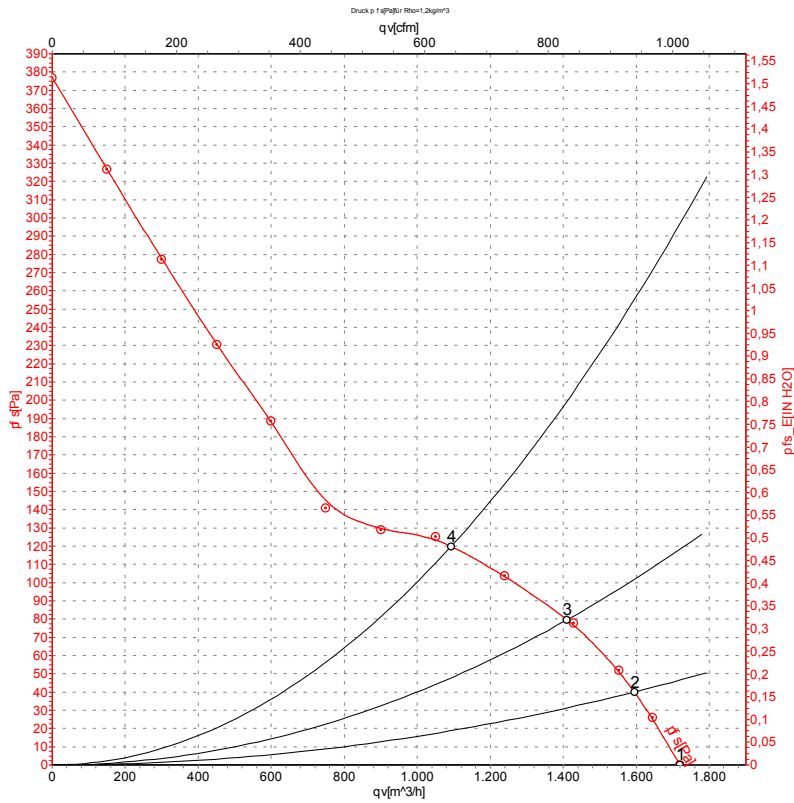

Measurement: LU-69121

Air performance measured as per ISO 5801 Installation category A. For detailed information on the measuring set-up, please contact ebm-papst. Suction-side noise levels: L<sub>wA</sub> measured as per ISO 13347 / L<sub>pA</sub> measured with 1m distance to fan axis. The values given are valid under the measuring conditions mentioned above and may vary according to the actual installation situation. With any deviation from the standard set-up, the specific values have to be checked and reviewed with the unit installed.

## Measured values

	Conn.	U	f	n	P <sub>e</sub>	I	qv	p <sub>fs</sub>
		V	Hz	min <sup>-1</sup>	W	A	m <sup>3</sup> /h	Pa
1	Y	400	50	2650	110	0.22	1720	0
2	Y	400	50	2620	126	0.23	1595	40
3	Y	400	50	2600	131	0.24	1410	80
4	Y	400	50	2595	131	0.24	1090	120

Conn. = Connection · U = Supply voltage · f = Frequency · n = Speed · P<sub>e</sub> = Power input · I = Current draw · qv = Air flow · p<sub>fs</sub> = Pressure increase



## Charts: Air flow 60 Hz Y

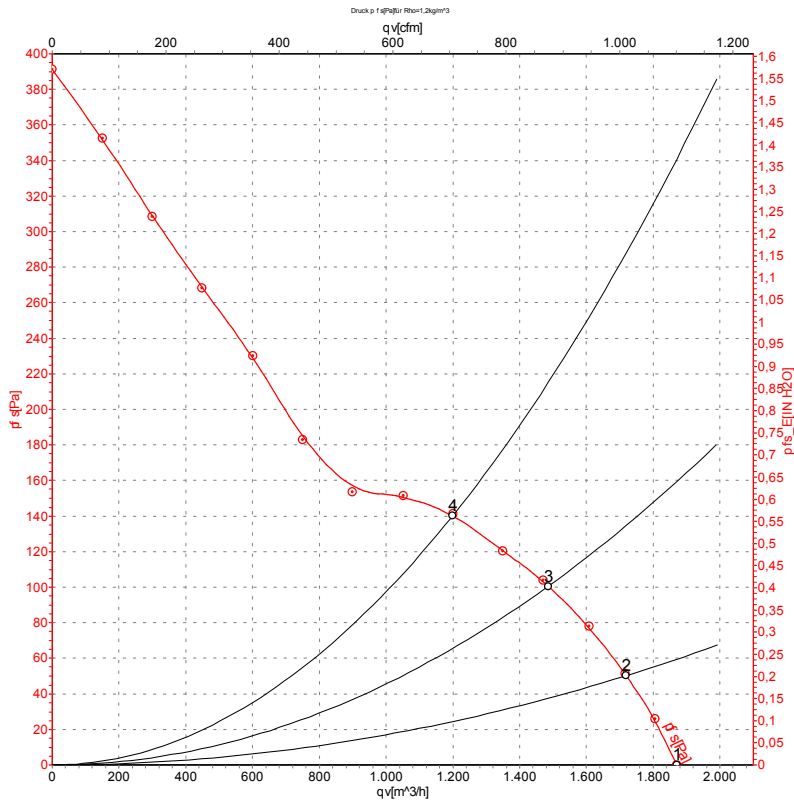

Measurement: LU-69123

Air performance measured as per ISO 5801 Installation category A. For detailed information on the measuring set-up, please contact ebm-papst. Suction-side noise levels: LwA measured as per ISO 13347 / LpA measured with 1m distance to fan axis. The values given are valid under the measuring conditions mentioned above and may vary according to the actual installation situation. With any deviation from the standard set-up, the specific values have to be checked and reviewed with the unit installed.

## Measured values

	Conn.	U	f	n	Pe	I	qv	Pfs
		V	Hz	min <sup>-1</sup>	W	A	m <sup>3</sup> /h	Pa
1	Y	400	60	2950	160	0.26	1870	0
2	Y	400	60	2850	177	0.28	1720	50
3	Y	400	60	2810	184	0.29	1485	100
4	Y	400	60	2805	184	0.29	1200	140

Conn. = Connection · U = Supply voltage · f = Frequency · n = Speed · Pe = Power input · I = Current draw · qv = Air flow · Pfs = Pressure increase

