

Product Data Sheet 4656 NU

ebmpapst

The engineer's choice



4656 NU

INDEX

1 General 3

2 Mechanics 3

2.1 GENERAL..... 3

2.2 CONNECTIONS 4

3 Operating Data 5

3.1 ELECTRICAL OPERATING DATA 5

3.2 OPERATING DATA - ELECTRICAL INTERFACE - OUTPUT..... 6

3.3 ELECTRICAL FEATURES 6

3.4 AERODYNAMICS 6

3.5 SOUND DATA 8

4 Environment..... 8

4.1 GENERAL..... 8

4.2 CLIMATIC REQUIREMENTS*)..... 8

5 Safety 9

5.1 ELECTRICAL SAFETY 9

5.2 APPROVAL TESTS 9

6 Reliability..... 9

6.1 GENERAL..... 9

1 General

Fan type	Fan
Rotating direction looking at rotor	Clockwise
Airflow direction	Air intake over struts
Bearing system	Ball bearing
Mounting position	Any
Balancing grade	2,5

2 Mechanics**2.1 General**

Width	119,0 mm	
Height	119,0 mm	
Depth	38,0 mm	
Diameter	0,0 mm	
Mass	0,550 kg	
Housing material	Metal	
Impeller material	Metal	
Max. torque when mounted across both mounting flanges	wire outlet corner: 190 Ncm remaining corners: 310 Ncm	
Screw size	ISO 4762 - M4 degreased, without an additional brace and without washer	

2.2 Connections

Electrical connection	Plug	
Lead wire length	See drawing	
Tolerance		
Tube length	See drawing	
Tolerance		
Wire size (AWG)		
Insulation diameter		
Plug	See drawing	
Contact	See drawing	

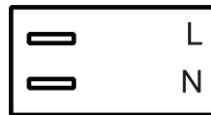

3 Operating Data

3.1 Electrical Operating Data

Measurement conditions: Normal air density = 1,2 kg/m³; Temperature 23°C +/- 3°C; Motor axis horizontal; warm-up time before measuring 5 minutes (unless otherwise specified).
In the intake and outlet area should not be any solid obstruction within 0,5 m.

$\Delta p = 0$: corresp. to free air flow (see section 3.4)

I: corresp. to RMS line current

230,0 V 230 V

3.2 Operating Data - Electrical Interface - Output

Tacho type	None
------------	------

3.3 Electrical Features

Locked rotor protection	Impedance
Locked rotor current at U_n	

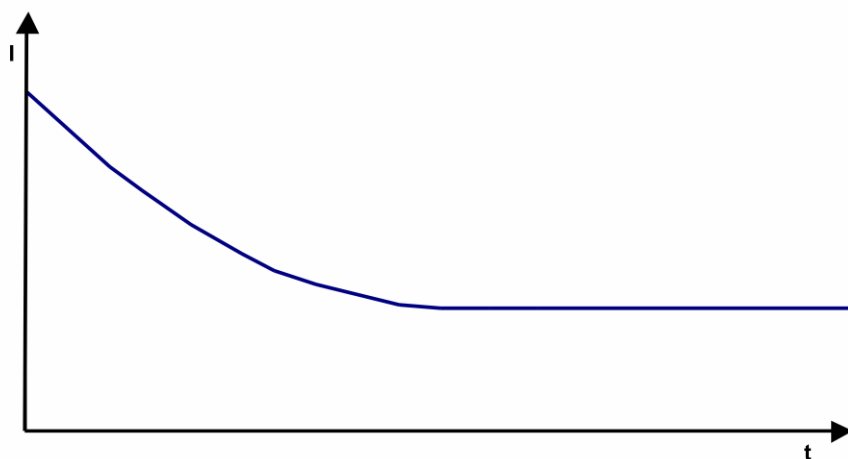

3.4 Aerodynamics

Measurement conditions: Measured with a double chamber intake rig acc. to DIN EN ISO 5801.
 Normal air density = 1,2 kg/m³; Temperature 23°C +/- 3°C;
 In the intake and outlet area should not be any solid obstruction within 0,5 m.
 The information is only valid under the specified test conditions and may be changed by the installation conditions. If there are deviations from the standard test conditions, the characteristic values must be checked under the installed conditions.

a.) Operation condition:
 2.600 1/min at free air flow Frequency: 50 Hz

Max. free-air flow ($\Delta p = 0 / \dot{V} = \text{max.}$)	146,0 m ³ /h
Max. static pressure ($\Delta p = \text{max.} / \dot{V} = 0$)	78 Pa

b.) Operation condition:
 2.950 1/min at free air flow Frequency: 60 Hz

Max. free-air flow ($\Delta p = 0 / \dot{V} = \text{max.}$)	170,0 m ³ /h
Max. static pressure ($\Delta p = \text{max.} / \dot{V} = 0$)	90 Pa

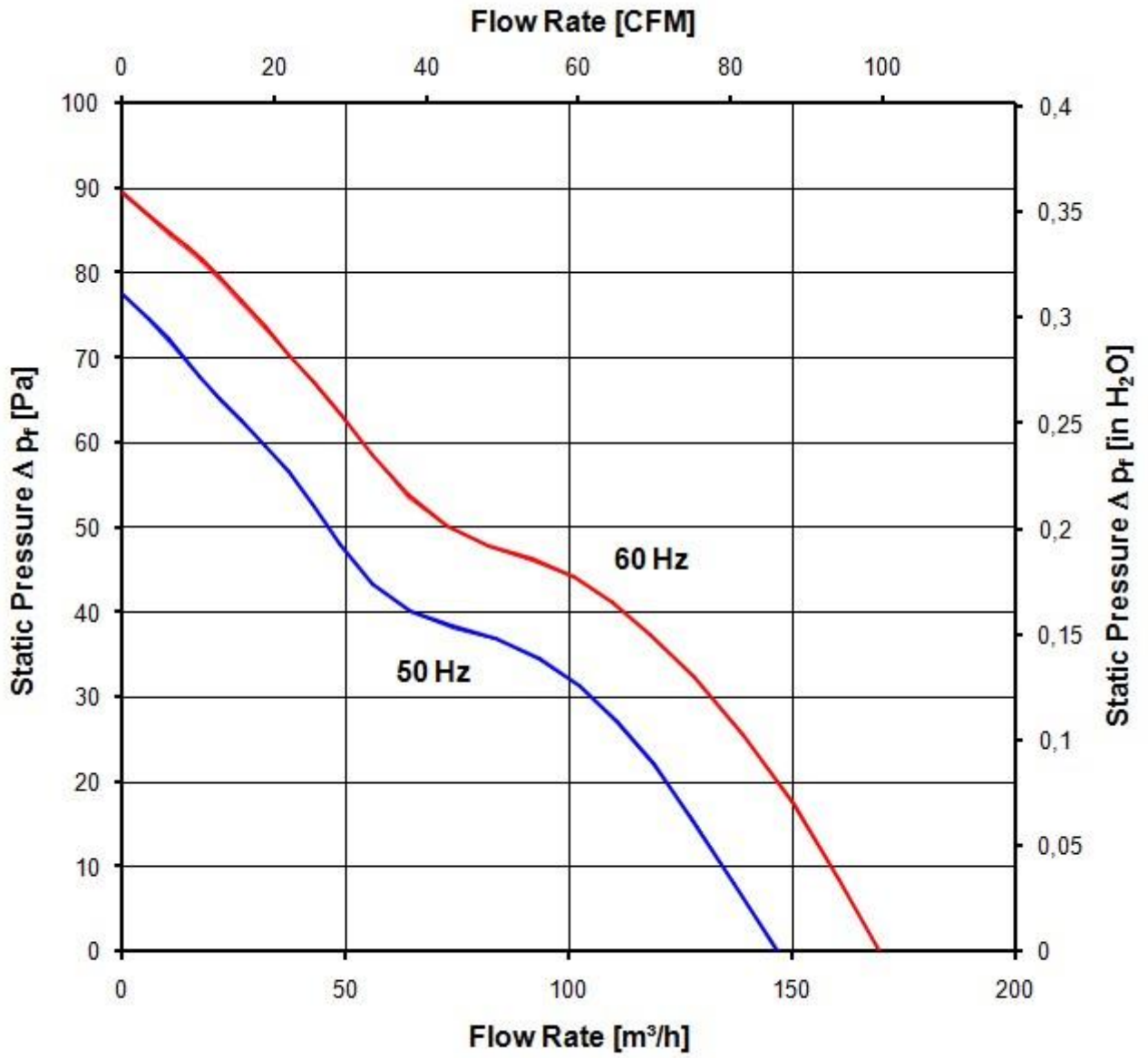

3.5 Sound Data

Measurement conditions: Sound pressure level: 1 Meter distance between microphone and the air intake.
 Sound power level: Acc. to DIN 45635 part 38 (ISO 10302)
 Measured in a semianchoic chamber with a background noise level of $L_p(A) < 5 \text{ dB}(A)$
 For further measurement conditions see section 3.4

a.) Operation condition:

2.600 1/min at free air flow

Frequency: 50 Hz

Optimal operating point	110,0 m ³ /h @ 25 Pa	
Sound power level at the optimal operating point	5,4 bel(A)	
Sound pressure level at free air flow, measured in rubber bands	44,0 dB(A)	

b.) Operation condition:

2.950 1/min at free air flow

Frequency: 60 Hz

Optimal operating point	120,0 m ³ /h @ 31 Pa	
Sound power level at the optimal operating point	5,7 bel(A)	
Sound pressure level at free air flow, measured in rubber bands	48,0 dB(A)	

4 Environment

4.1 General

Min. permitted ambient temperature TU min.	-40 °C / 50 Hz -40 °C / 60 Hz	
Max. permitted ambient temperature TU max.	85 °C / 50 Hz 90 °C / 60 Hz	
Min. permitted storage temperature TL min.	-40 °C	
Max. permitted storage temperature TL max.	100 °C	

4.2 Climatic Requirements *)

Humidity requirements	humid temperature, cyclic; according to DIN EN 60068-2-38, 10 cycle and condensation water check; according to DIN EN ISO 6270-2, 14 days	
Water exposure	Splash water check IPX4; according to DIN EN 60529 VDE 0470, not certified	
Dust requirements	Dust check IP5X; according to DIN EN 60529 VDE 0470, not certified	
Salt fog requirements	None	

*) Permitted application area:

The product is for the use in partial sheltered rooms or open, roofed areas. Direct exposure to water is allowed provided that this does not prevent the normal operation. Saline ambient conditions must be avoided.

Pollution degree 3 (according DIN EN 60664-1)

It occurs conductive pollution or dry non-conductive pollution which becomes conductive due to condensation.

5 Safety

5.1 Electrical Safety

Dielectric strength DIN EN 60950 (VDE 0805) and DIN EN 60335 (VDE 0700) A.) Type test Measuring conditions: After 48h of storage at 95% R.H. and 25°C. No arcing or breakdown is allowed! All connections together to ground. B.) Routine test Measuring conditions: At indoor climate. No arcing or breakdown is allowed! All connections together to ground.	1500 VAC / 1 Min. 1500 VAC / 1 Sec.
Isolation resistance Measuring conditions: After 48h of storage at 95% R.H. and 25°C measured with U=500 VDC for 1 min.	RI > 50 MOhm
clearance / creepage distance	2,0 mm / 1,8 mm
Protection class	I

5.2 Approval Tests

CE	EC Declaration of Conformity	Yes
EAC	Eurasian Conformity	Yes
UL	Underwriters Laboratories	Yes / UL507, Electric Fans
VDE	Association for Electrical, Electronic and Information Technologies	Yes / Approval acc. to EN 60950 (VDE 0805) - Information technology equipment
CSA	Canadian Standards Association	Yes / C22.2 No. 113 Fans and Ventilators
CCC	China Compulsory Certification	Yes / GB 12350 Safety Requirements for small Power Motors

The approval tests are observed to:

U approval max.: 230 V / f: 60 Hz @ TU approval max.: 90 °C

6 Reliability

6.1 General

Life expectancy L10 at TU = 40 °C	37.500 h / 50 Hz 40.000 h / 60 Hz	
Life expectancy L10 at TU max.	15.000 h / 50 Hz 15.000 h / 60 Hz	

Copying of this document, and giving it to others and the use or communication of the contents thereof, are prohibited without the written consent of the manufacturer. All rights are reserved in the event of the grant of a patent or the registration of a utility model or design.

Schutzvermerk nach DIN 34, beachten

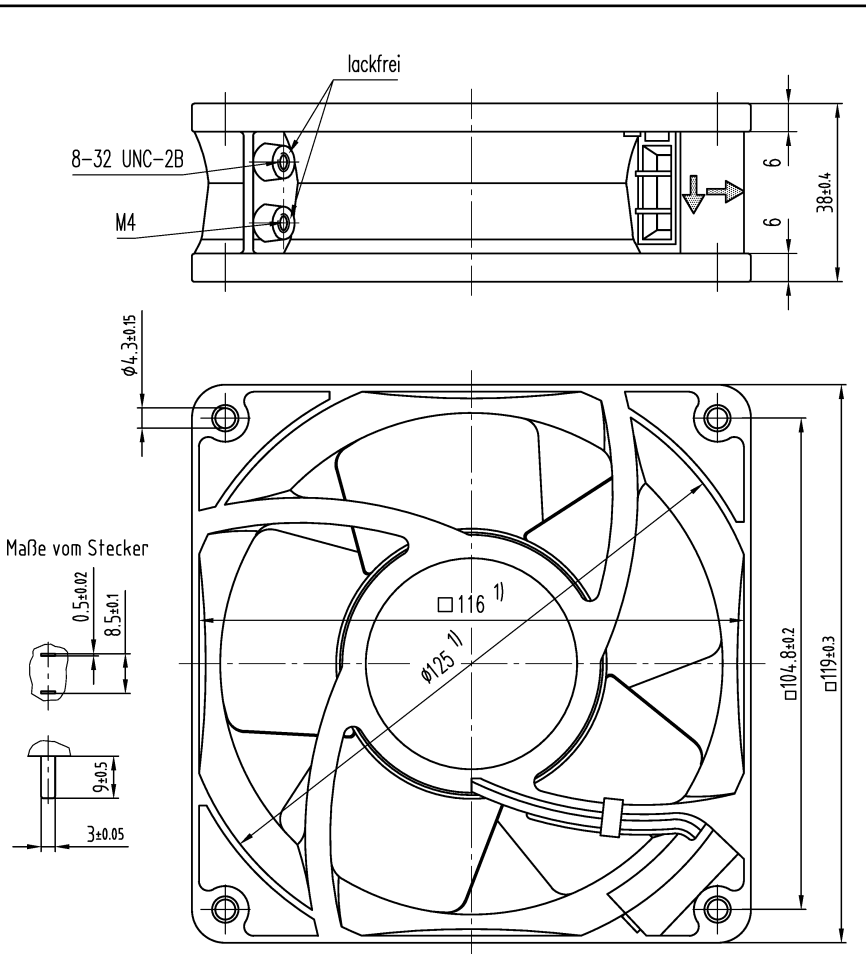

Maße vom Stecker

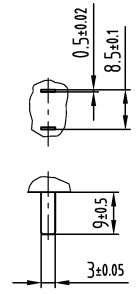

1) Maße für Montagewand
 - Axialspiel: mit Feder spielfrei verspannt

Allgemeintoleranzen

516					Datum	Name	Artikel	Maßstab
210					Erstellt			
232					Geprüft			
235								
240					PAPST		Zchg.-Nr.	Blatt
082	Zur Verwendung im Verteiler freigegeben von	Änd.-Nr.	Datum	Geändert von	PAPST-MOTOREN GmbH & Co KG D-78112 St.Georgen Germany		Ers.f.Zchg.:	