



The engineer's choice

**ebmpapst**

# 4656 EZ

## INDEX

<b>1</b>	<b>General</b> .....	<b>3</b>
<b>2</b>	<b>Mechanics</b> .....	<b>3</b>
2.1	GENERAL .....	3
2.2	CONNECTIONS .....	4
<b>3</b>	<b>Operating Data</b> .....	<b>5</b>
3.1	ELECTRICAL OPERATING DATA .....	5
3.2	OPERATING DATA - ELECTRICAL INTERFACE -OUTPUT .....	6
3.3	ELECTRICAL FEATURES .....	6
3.4	AERODYNAMIC .....	6
3.5	SOUND DATA .....	8
<b>4</b>	<b>Environment</b> .....	<b>8</b>
4.1	GENERAL .....	8
4.2	CLIMATIC REQUIREMENTS*) .....	8
<b>5</b>	<b>Safety</b> .....	<b>9</b>
5.1	ELECTRICAL SAFETY .....	9
5.2	APPROVAL TESTS .....	9
<b>6</b>	<b>Reliability</b> .....	<b>9</b>
6.1	GENERAL .....	9

## 1 General

Fan type	Fan without chassis
Rotational direction looking at rotor	clockwise
Airflow direction	Air outlet over flange
Bearing system	Ball bearing
Mounting position	any
Balancing grade	2,5

## 2 Mechanics

### 2.1 General

Width	0,0 mm	
Height	0,0 mm	
Depth	39,0 mm	
Diameter	108,0 mm	
Weight	0,380 kg	
Housing material	--	
Impeller material	Metal	

## 2.2 Connections

Electrical connection	Wires	
Length of lead wire	L = 375,0 mm	
Tolerance	+/- 10,0 mm	
Length of tube	see drawing	
Tolerance		
Wire gauge (AWG)	18	
Insulation diameter	2,06 mm	
Plug	see drawing	
Contact	see drawing	



	Colour	Operation
Wire 1	black	L
Wire 2	black	N

### 3 Operating Data

#### 3.1 Electrical Operating Data

For checking purposes the electrical data can be specified without an intake nozzle / aperture plate as well. For this the data have to be defined by the appropriate quality assurance.

#### Electrical Operating Data with intake nozzle (For checking purposes)

Measurement conditions: Normal air density = 1,2 kg/m<sup>3</sup>; Temperature 23°C +/- 3°C; Motor axis horizontal; warm-up time before measuring 5 minutes (unless otherwise specified).  
In the intake and outlet area should not be any solid obstruction within 0,5 m.

Measurement setup:	Measured with an aperture plate
Aperture plate diameter:	109 mm
Distance between mounting traverse and aperture plate:	20,5 mm

$\Delta p = 0$ : corresp. to free air flow (see section 3.4)

I: corresp. to RMS line current

Features	Condition	Symbol	Values	
			50 Hz	60 Hz
Frequency	$\Delta p = 0$	f	230,0 V	230,0 V
Nominal voltage	$\Delta p = 0$	$U_N$	230,0 V	230,0 V
Tolerance			+ 6,0 %      - 10,0 %	+ 6,0 %      - 10,0 %
Power consumption	$\Delta p = 0$	P	19,0 W	18,0 W
Tolerance			+ - 10,0 %	+ - 10,0 %
Speed	$\Delta p = 0$	n	2.600 1/min	2.950 1/min
Tolerance			+ - 3,0 %	+ - 3,0 %

### 3.2 Operating Data - Electrical Interface -Output

Tacho type	None
------------	------

### 3.3 Electrical Features

Locked rotor protection	Impedance
Locked rotor current at Un	

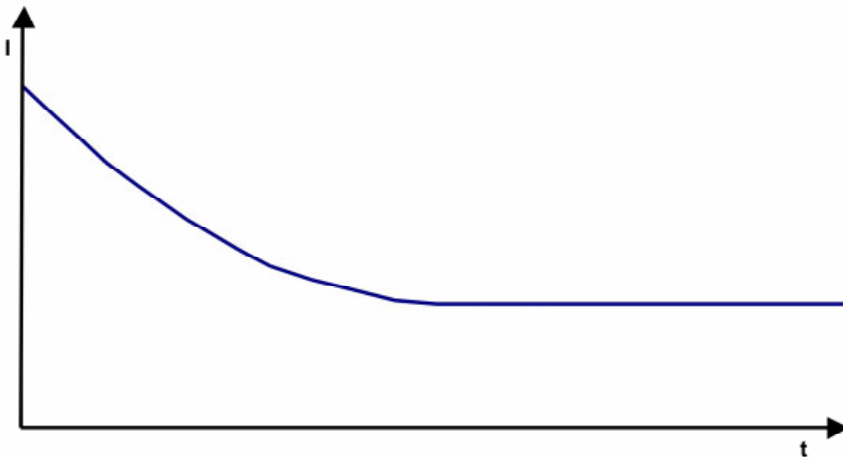

### 3.4 Aerodynamic

Measurement conditions: Measured with a double chamber intake rig acc. to DIN EN ISO 5801. Normal air density = 1,2 kg/m<sup>3</sup>; Temperature 23°C +/- 3°C; In the intake and outlet area should not be any solid obstruction within 0,5 m. The information is only valid under the specified test conditions and may be changed by the installation conditions. If there are deviations from the standard test conditions, the characteristic values must be checked under the installed conditions.

Measurement setup:	Measured with an aperture plate
Aperture plate diameter:	109 mm
Distance between mounting traverse and aperture plate:	20,5 mm

a.) Operation condition:  
 2.600 1/min at free air flow                      Frequency: 50 Hz

Max. free-air flow ( $\Delta p = 0 / \dot{V} = \text{max.}$ )	124,0 m <sup>3</sup> /h
Max. static pressure ( $\Delta p = \text{max.} / \dot{V} = 0$ )	72 Pa

b.) Operation condition:  
 2.950 1/min at free air flow                      Frequency: 60 Hz

Max. free-air flow ( $\Delta p = 0 / \dot{V} = \text{max.}$ )	142,0 m <sup>3</sup> /h
Max. static pressure ( $\Delta p = \text{max.} / \dot{V} = 0$ )	77 Pa

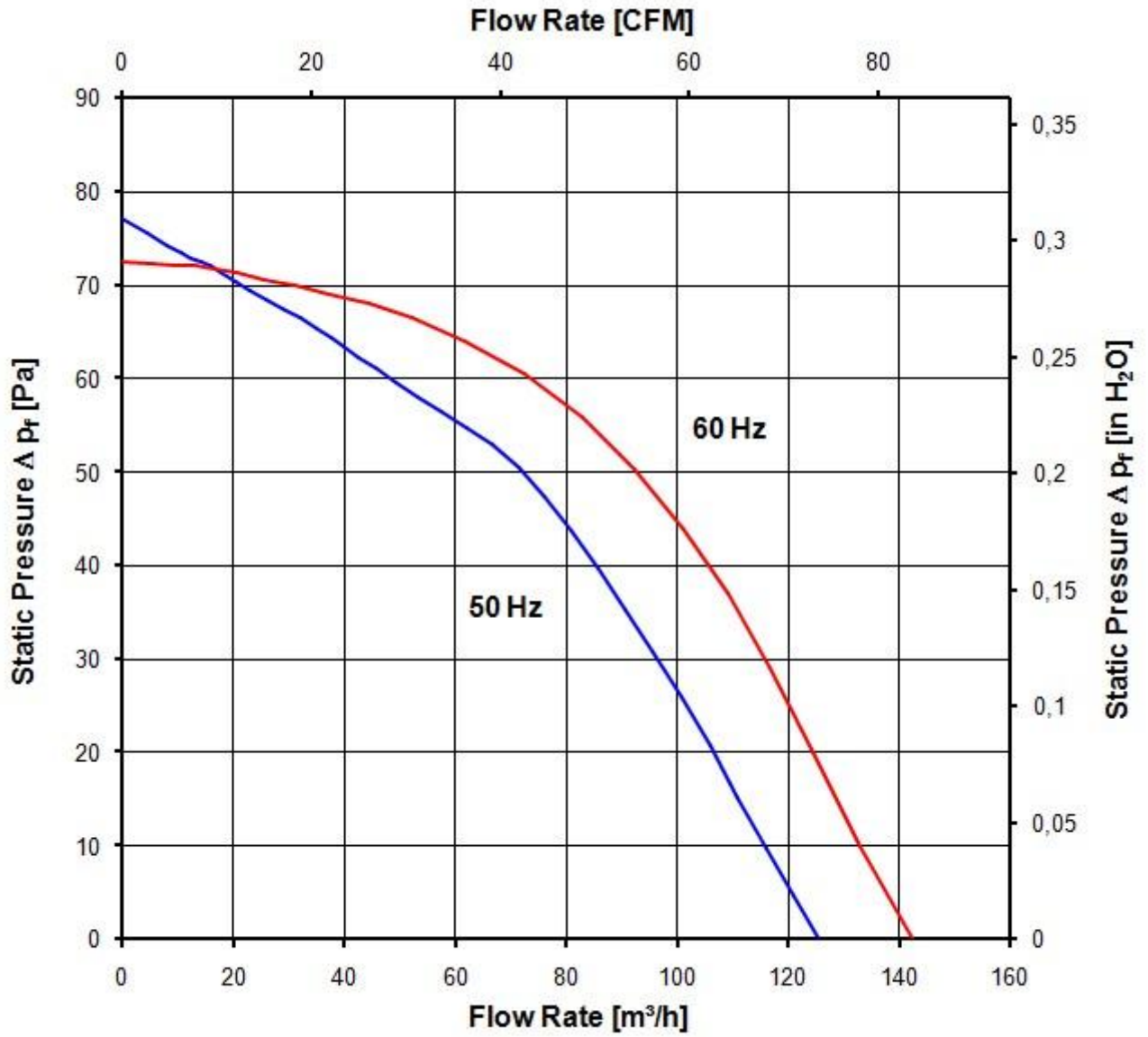

### 3.5 Sound Data

Measurement conditions: Sound pressure level: 1 Meter distance between microphone and the air intake.  
 Sound power level: Acc. to DIN 45635 part 38 (ISO 10302)  
 Measured in a semianchoic chamber with a background noise level of  $L_p(A) < 5 \text{ dB(A)}$   
 For further measurement conditions see section 3.4

a.) Operation condition:  
 2.600 1/min at free air flow Frequency: 50 Hz

Sound pressure level at free air flow, measured in rubber bands	39,0 dB(A)	
---	------------	--

b.) Operation condition:  
 2.950 1/min at free air flow Frequency: 60 Hz

Sound pressure level at free air flow, measured in rubber bands	42,0 dB(A)	
---	------------	--

## 4 Environment

### 4.1 General

Min. permitted ambient temperature TU min.	-40 °C / 50 Hz -40 °C / 60 Hz	
Max. permitted ambient temperature TU max.	65 °C / 50 Hz 70 °C / 60 Hz	
Min. permitted storage temperature TL min.	-40 °C	
Max. permitted storage temperature TL max.	100 °C	

### 4.2 Climatic requirements\*)

Humidity requirements	humid heat, constant; according to DIN EN 60068-2-78, 14 days	
Water exposure	None	
Dust requirements	None	
Salt fog requirements	None	

\*) Permitted application area:

The product is intended for use in sheltered rooms with controlled temperature and controlled humidity. Directly exposure to water must be avoided.

Pollution degree 1 (according DIN EN 60664-1)

There is either no pollution or it occurs only dry, non-conductive pollution. The pollution has no negative impact.



## 5 Safety

### 5.1 Electrical Safety

Dielectric strength DIN EN 60950 (VDE 0805) and DIN EN 60335 (VDE 0700) A.) Type test Measuring conditions: After 48h of storage at 95% R.H. and 25°C. No arcing or breakdown is allowed! All connections together to ground. B.) Routine test Measuring conditions: At indoor climate. No arcing or breakdown is allowed! All connections together to ground.	1500 VAC / 1 Min.  1500 VAC / 1 Sec.
Isolation resistance Measuring conditions: After 48h of storage at 95% R.H. and 25°C measured with U=500 VDC for 1 min.	RI > 50 MOhm
clearance / creepage distance	2,0 mm / 1,8 mm
Protection class	I

### 5.2 Approval Tests

CE	Yes
UL	Yes / UL507, Electric Fans
VDE	Yes / Approval acc. to EN 60950 (VDE 0805) - Information technology equipment
CSA	No
CCC	Yes / GB 12350 Safety Requirements for small Power Motors

The approval tests are observed to:

U approval max.: 230 V / f: 60 Hz @ TU approval max.: 65 °C

## 6 Reliability

### 6.1 General

Life expectancy L10 at TU = 40 °C	37.500 h / 50 Hz	
Life expectancy L10 at TU max.	15.000 h / 50 Hz	

Copying of this document, and giving it to others and the use or communication of the contents thereof, are forbidden without express authority. Offences are liable to the payment of damages. All rights are reserved. In the event of the grant of a patent, or the registration of a utility model or design.

Schutzmerk nach DIN 24, beachten

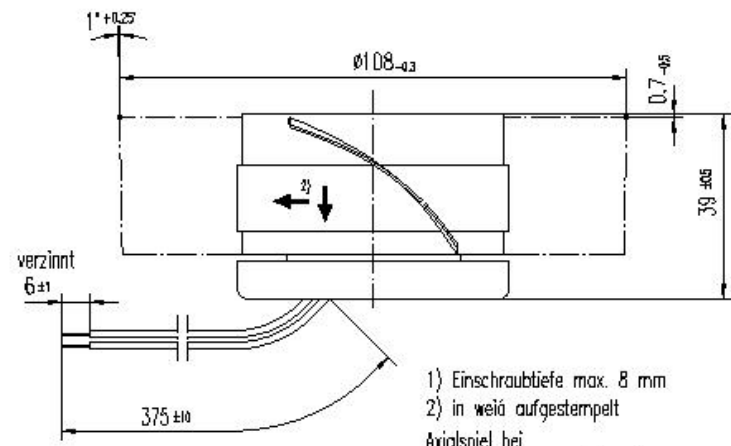
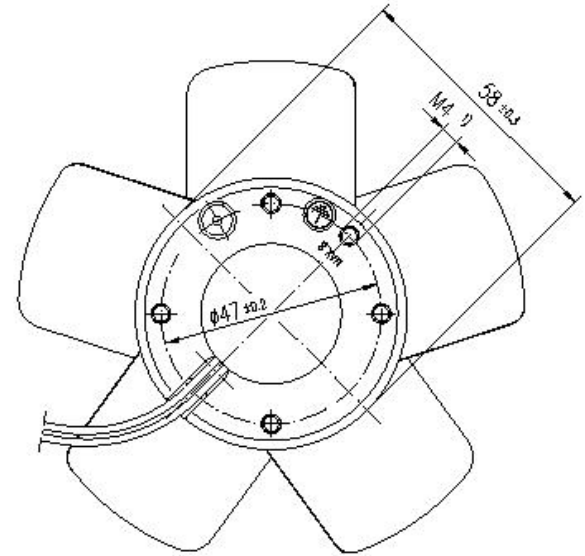

- 1) Einschraubtiefe max. 8 mm
  - 2) in weiß aufgestempelt
- Axialspiel bei
- Kugellagerung (K): 0 (mit Federausgleich)
  - Gleitlagerung (G): 0.1 - 0.6

084  
210  
232  
235  
240  
516

Allgemeintoleranzen				DIN 2768 - mK		gilt für: 924 4014 942 (K) 4656 EZ 924 4014 945 (K) 4656 EZR 924 4014 951 (G) 4580 EZ-951 ① 924 4014 007 (K) 4656 EZU	
			Datum	Name	Artikel	Notstab	
			Erstellt	01.09.95	Kieninger	1:1	
			Geprüft	29.04.96	Winkel G.		
0	Erzeugung	25.03.97	Koletzki M.	<b>PAPST</b> PAPST-MOTOREN GmbH & Co KG D-78112 St.Georgen Germany		Zchg.-Nr.	924 4014 942
Index	Znd.-Nr.	Datum	Geändert von			Ers.f.Zchg.	K 2, 924, 4014
Zur Verwendung im Verteiler freigegeben von Koletzki M. am 25.03.97						Blatt 2	