

AC centrifugal fan

forward curved, dual inlet
with housing (flange)

ASIA PACIFIC SHENGRUI LIMITED

Phone +00852 56261528

info@apacfan.com

www.apacfan.com

Limited partnership · Headquarters Muldingen
County court Stuttgart · HRA 590344

General partner Elektrobau Muldingen GmbH · Headquarters Muldingen
County court Stuttgart · HRB 590142



Nominal data

Type	D2D160-BE02-14				
Motor	M2D074-LA				
Phase		3~	3~	3~	3~
Nominal voltage	VAC	230	230	400	400
Connection		Δ	Δ	Y	Y
Frequency	Hz	50	60	50	60
Type of data definition		ml	ml	ml	ml
Valid for approval / standard		CE	CE	CE	CE
Speed	min ⁻¹	2700	3000	2700	3000
Power input	W	700	1055	700	1055
Current draw	A	2.2	3.0	1.28	1.7
Min. back pressure	Pa	400	500	400	500
Min. ambient temperature	°C	-25	-25	-25	-25
Max. ambient temperature	°C	75	75	75	75
Starting current	A	5.34	5.54	5.34	5.54

ml = max. load · me = max. efficiency · fa = running at free air · cs = customer specs · cu = customer unit
Subject to alterations

Data according to ErP directive

Installation category	A
Efficiency category	Static
Variable speed drive	No
Specific ratio*	1.01

* Specific ratio = $1 + p_{fs} / 100\,000\text{ Pa}$

	Actual	Request 2013	Request 2015
Overall efficiency η_{es}	32.4	28.5	35.5
Efficiency grade N	40.9	37	44
Power input P_e	kW	0.46	
Air flow q_v	m ³ /h	1000	
Pressure increase p_{fs}	Pa	538	
Speed n	min ⁻¹	2820	

Data established at point of optimum efficiency



D2D160-BE02-14

AC centrifugal fan

forward curved, dual inlet

with housing (flange)

Technical features

Mass	10.82 kg
Size	160 mm
Surface of rotor	Coated in black
Material of impeller	Sheet steel, galvanised
Housing material	Sheet steel, galvanised
Material of guard grille	Steel, galvanised and plastic-coated in white aluminium (RAL 9006)
Motor suspension	Motor mounted anti-vibration on both sides
Direction of rotation	Counter-clockwise, seen on rotor
Type of protection	IP 00
Insulation class	"F"
Humidity class	F2-1
Max. permissible ambient motor temp. (transp./ storage)	+ 80 °C
Min. permissible ambient motor temp. (transp./storage)	- 40 °C
Mounting position	Any
Condensate discharge holes	None, open rotor
Operation mode	S1
Motor bearing	Ball bearing
Touch current acc. IEC 60990 (measuring network Fig. 4, TN system)	< 0.75 mA
Electrical leads	With plug
Motor protection	Thermal overload protector (TOP) brought out
Cable exit	Axial
Protection class	I (if protective earth is connected by customer)
Product conforming to standard	EN 60335-1; CE
Approval	CCC; UL 1004-1; CSA C22.2 Nr.100



D2D160-BE02-14

AC centrifugal fan

forward curved, dual inlet
with housing (flange)

Product drawing

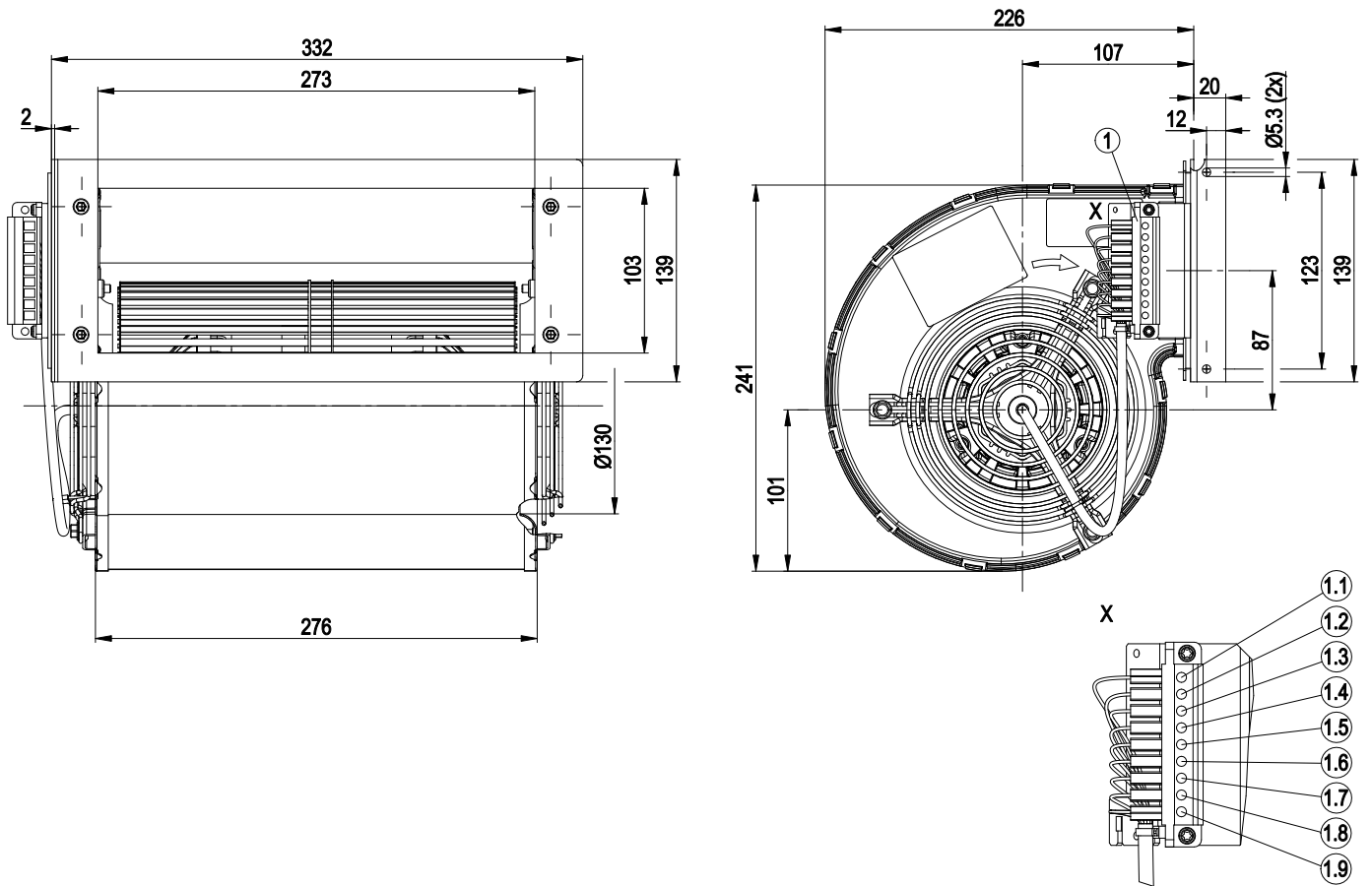

1	Connection line PFA AWG20, strip Weidmüller STV S 9 SS and 9x brass lead tips crimped
1.1	black
1.2	Blue
1.3	brown
1.4	grey
1.5	green / yellow
1.6	grey
1.7	green
1.8	white
1.9	yellow



AC centrifugal fan

forward curved, dual inlet
with housing (flange)

Connection screen

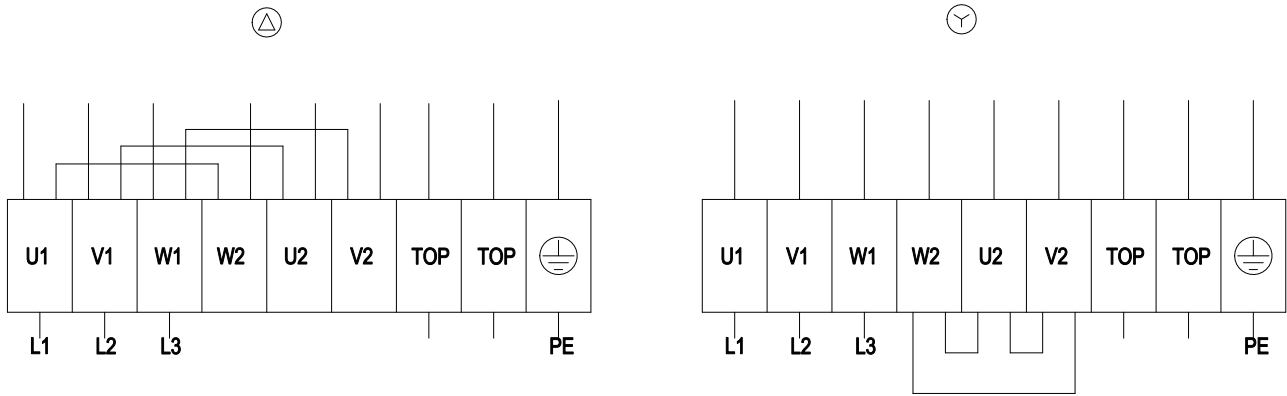

Δ	Delta-connection	Y	Star connection	L1	= U1 = black
L2	= V1 = blue	L3	= W1 = brown	W2	yellow
U2	green	V2	white	TOP	2 x grey
PE	green / yellow				

AC centrifugal fan

forward curved, dual inlet

with housing (flange)

Charts: Air flow 50 Hz

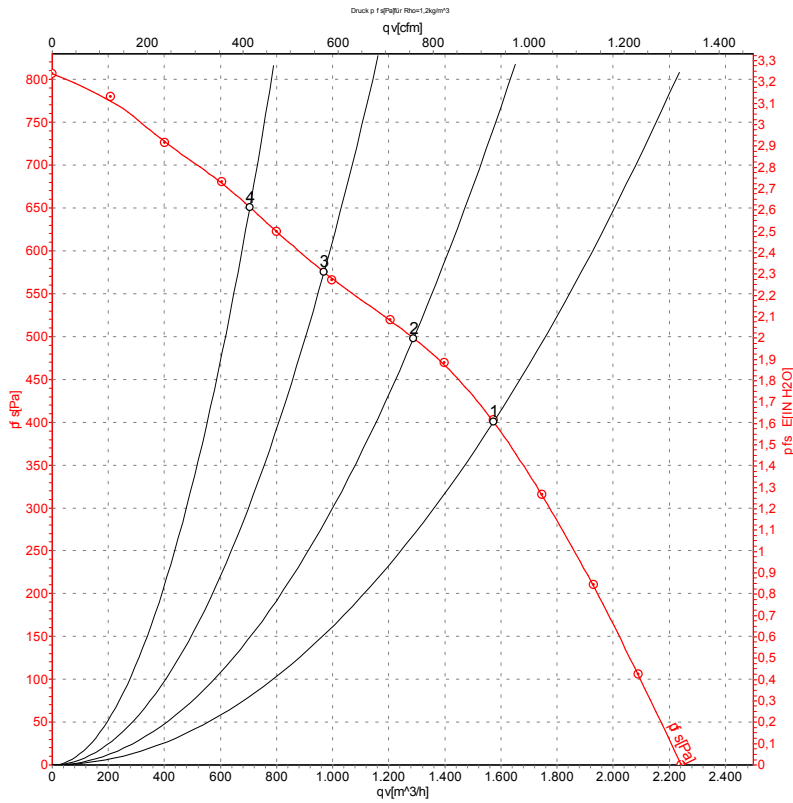

Measurement: LU-112482

Air performance measured as per ISO 5801 Installation category A. For detailed information on the measuring set-up, please contact ebm-papst. Suction-side noise levels: L_{wA} measured as per ISO 13347 / L_{pA} measured with 1m distance to fan axis. The values given are valid under the measuring conditions mentioned above and may vary according to the actual installation situation. With any deviation from the standard set-up, the specific values have to be checked and reviewed with the unit installed.

Measured values

	U	f	n	P _e	I	qv	P _{fs}
	V	Hz	min ⁻¹	W	A	m ³ /h	Pa
1	400	50	2700	700	1.28	1575	400
2	400	50	2775	564	1.10	1290	500
3	400	50	2825	454	0.96	970	575
4	400	50	2855	387	0.89	705	650

U = Supply voltage · f = Frequency · n = Speed · P_e = Power input · I = Current draw · qv = Air flow · p_{fs} = Pressure increase



AC centrifugal fan

forward curved, dual inlet

with housing (flange)

Charts: Air flow 60 Hz

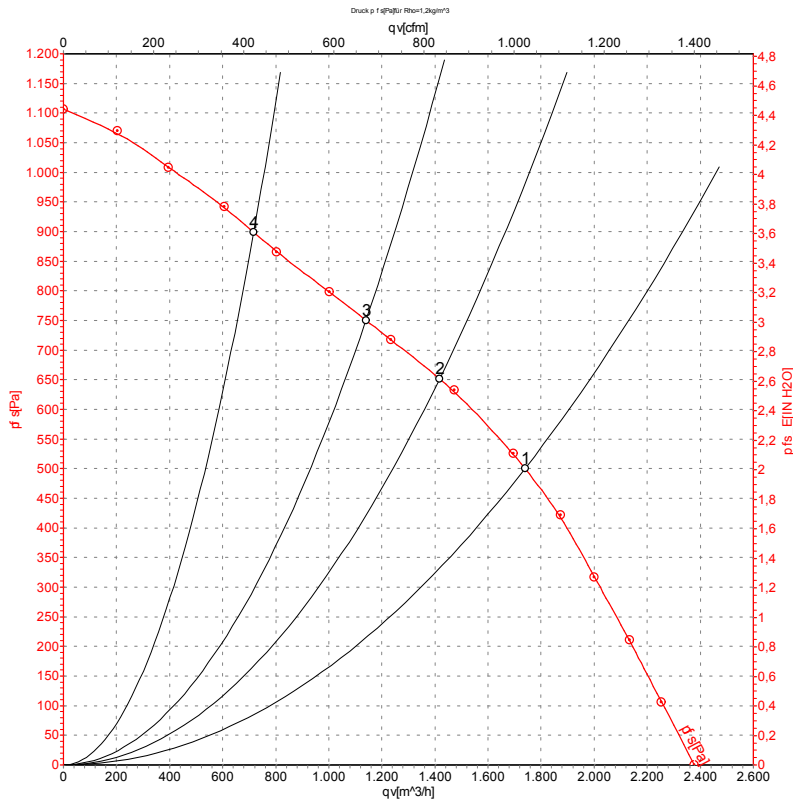

Measurement: LU-112483

Air performance measured as per ISO 5801 Installation category A. For detailed information on the measuring set-up, please contact ebm-papst. Suction-side noise levels: LwA measured as per ISO 13347 / LpA measured with 1m distance to fan axis. The values given are valid under the measuring conditions mentioned above and may vary according to the actual installation situation. With any deviation from the standard set-up, the specific values have to be checked and reviewed with the unit installed.

Measured values

	U	f	n	P _e	I	qv	P _{fs}
	V	Hz	min ⁻¹	W	A	m ³ /h	Pa
1	400	60	3000	1055	1.70	1740	500
2	400	60	3130	851	1.39	1415	650
3	400	60	3215	728	1.21	1140	750
4	400	60	3300	592	1.01	715	900

U = Supply voltage · f = Frequency · n = Speed · P_e = Power input · I = Current draw · qv = Air flow · P_{fs} = Pressure increase

