

G2E160-AY47-01

AC centrifugal fan

forward curved, single inlet

with housing (flange), for solid fuel heating systems



ASIA PACIFIC SHENGRUI LIMITED

Phone +00852 56261528

info@apacfan.com

www.apacfan.com



Nominal data

Type	G2E160-AY47-01		
Motor	M2E068-EC		
Phase		1~	1~
Nominal voltage	VAC	230	230
Frequency	Hz	50	60
Type of data definition		fa	ml
Valid for approval / standard		CE	CE
Speed	min ⁻¹	2100	2100
Power input	W	240	280
Current draw	A	1.05	1.23
Motor capacitor	µF	6	6
Capacitor voltage	VDB	400	400
Min. back pressure	Pa	0	50
Min. ambient temperature	°C	-25	-25
Max. ambient temperature	°C	50	30

ml = max. load · me = max. efficiency · fa = running at free air · cs = customer specs · cu = customer unit
Subject to alterations

Data according to ErP directive

Installation category	A
Efficiency category	Static
Variable speed drive	No
Specific ratio*	1.01

* Specific ratio = $1 + p_{fs} / 100\,000\text{ Pa}$

	Actual	Request 2013	Request 2015
Overall efficiency η_{es}	27.4	25.6	32.6
Efficiency grade N	38.8	37	44
Power input P_e	kW	0.16	
Air flow q_v	m ³ /h	365	
Pressure increase p_{fs}	Pa	442	
Speed n	min ⁻¹	2595	

Data established at point of optimum efficiency



AC centrifugal fan

forward curved, single inlet

with housing (flange), for solid fuel heating systems

Technical features

Mass	4 kg
Size	160 mm
Material of impeller	Sheet steel, galvanised
Housing material	Die-cast aluminium
Direction of rotation	Clockwise, seen on rotor
Type of protection	IP 44; Depending on installation and position
Insulation class	"B"
Humidity class	F0
Max. permissible ambient motor temp. (transp./ storage)	+ 80 °C
Min. permissible ambient motor temp. (transp./storage)	- 40 °C
Mounting position	Any
Condensate discharge holes	None
Operation mode	S1
Motor bearing	Ball bearing
Touch current acc. IEC 60990 (measuring network Fig. 4, TN system)	< 0.75 mA
Motor protection	Thermal overload protector (TOP) wired internally
Cable exit	Variable
Protection class	I (if protective earth is connected by customer)
Product conforming to standard	EN 60335-1; CE
Approval	CCC

AC centrifugal fan

forward curved, single inlet

with housing (flange), for solid fuel heating systems

Product drawing

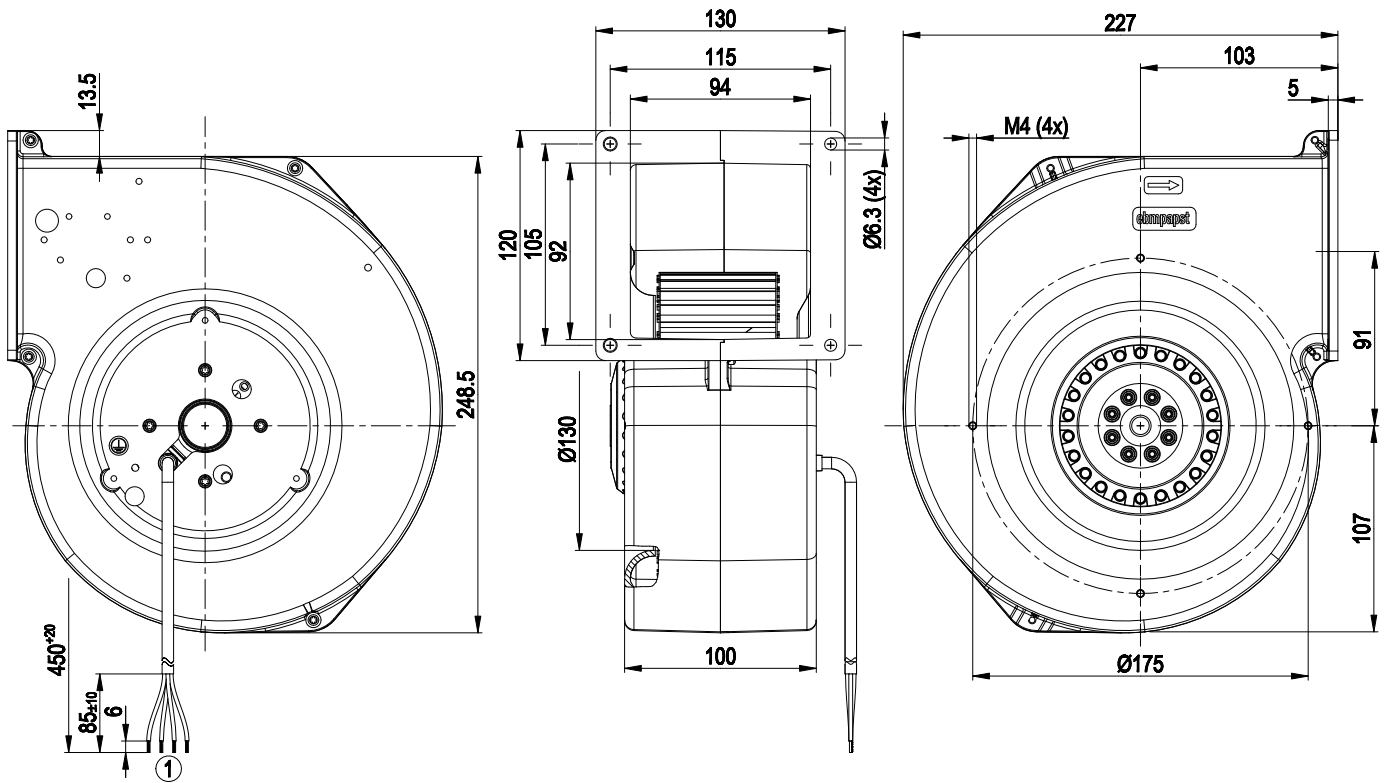

1 Connection line PVC 4G 0.5 mm², 4x brass lead tips crimped

Connection screen

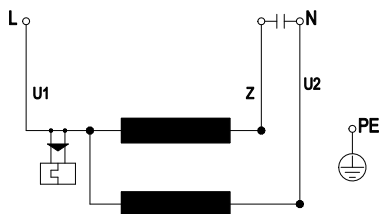

U1	blue	Z	brown	U2	black
PE	green/yellow				

AC centrifugal fan

forward curved, single inlet

with housing (flange), for solid fuel heating systems

Charts: Air flow 50 Hz

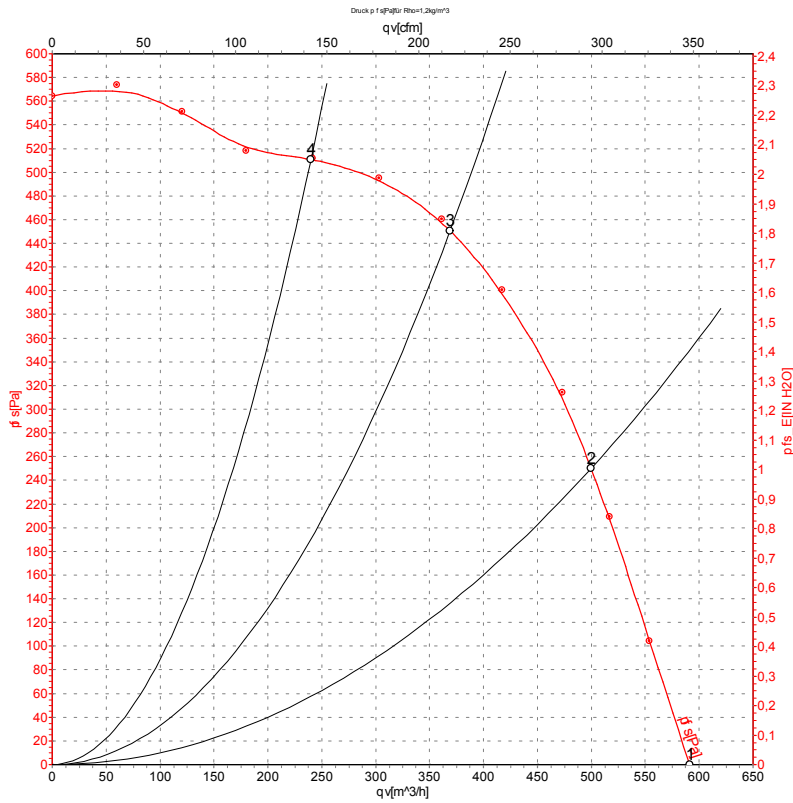

Measurement: LU-104987

Air performance measured as per ISO 5801 Installation category A. For detailed information on the measuring set-up, please contact ebm-papst. Suction-side noise levels: L_{wA} measured as per ISO 13347 / L_{pA} measured with 1m distance to fan axis. The values given are valid under the measuring conditions mentioned above and may vary according to the actual installation situation. With any deviation from the standard set-up, the specific values have to be checked and reviewed with the unit installed.

Measured values

	U	f	n	P _e	I	qv	P _{fs}
	V	Hz	min ⁻¹	W	A	m³/h	Pa
1	230	50	2100	240	1.05	590	0
2	230	50	2375	200	0.87	500	250
3	230	50	2585	164	0.71	370	450
4	230	50	2715	137	0.59	240	510

U = Supply voltage · f = Frequency · n = Speed · P_e = Power input · I = Current draw · qv = Air flow · P_{fs} = Pressure increase



AC centrifugal fan

forward curved, single inlet

with housing (flange), for solid fuel heating systems

Charts: Air flow 60 Hz

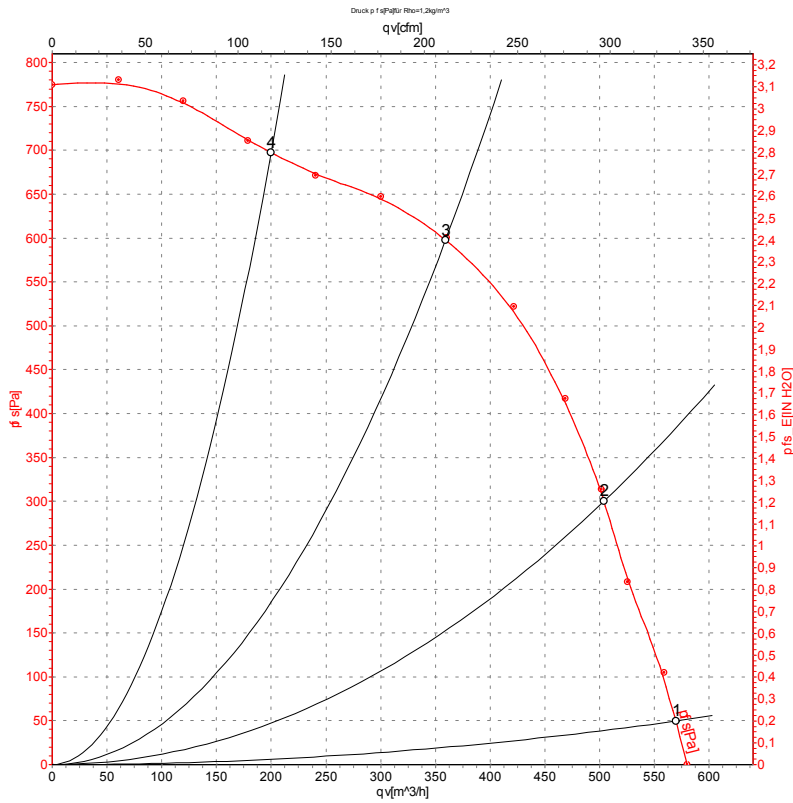

Measurement: LU-104989

Air performance measured as per ISO 5801 Installation category A. For detailed information on the measuring set-up, please contact ebmpapst. Suction-side noise levels: L_{wA} measured as per ISO 13347 / L_{pA} measured with 1m distance to fan axis. The values given are valid under the measuring conditions mentioned above and may vary according to the actual installation situation. With any deviation from the standard set-up, the specific values have to be checked and reviewed with the unit installed.

Measured values

	U	f	n	P _e	I	qv	P _{fs}
	V	Hz	min ⁻¹	W	A	m ³ /h	Pa
1	230	60	2100	280	1.23	570	50
2	230	60	2500	258	1.12	505	300
3	230	60	2940	210	0.94	360	600
4	230	60	3180	172	0.80	200	700

U = Supply voltage · f = Frequency · n = Speed · P_e = Power input · I = Current draw · qv = Air flow · P_{fs} = Pressure increase

