

K3G250-RE21-08

EC centrifugal module - RadiCal

backward-curved, single-intake

with housing

ASIA PACIFIC SHENGRUI LIMITED

Phone +00852 56261528

info@apacshengrui.com

www.apacfan.com

Nominal data

Type	K3G250-RE21-08	
Motor	M3G055-DF	
Phase		1~
Nominal voltage	VAC	115
Nominal voltage range	VAC	100 .. 130
Frequency	Hz	50/60
Method of obtaining data		ml
Speed (rpm)	min ⁻¹	2500
Power consumption	W	163
Current draw	A	2.3
Min. ambient temperature	°C	-25
Max. ambient temperature	°C	60

ml = Max. load · me = Max. efficiency · fa = Free air · cs = Customer specification · ce = Customer equipment
Subject to change



Technical description

Weight	2.7 kg
Fan size	250 mm
Rotor surface	Thick-film passivated
Electronics housing material	Die-cast aluminum
Impeller material	PA plastic, galvanized sheet-metal plate
Housing material	PA plastic
Number of blades	7
Direction of rotation	Clockwise, viewed toward rotor
Degree of protection	IP54
Insulation class	"B"
Moisture (F) / Environmental (H) protection class	H1
Max. permitted ambient temp. for motor (transport/storage)	+ 80 °C
Min. permitted ambient temp. for motor (transport/storage)	- 40 °C
Installation position	Any
Condensation drainage holes	None, open rotor
Mode	S1
Motor bearing	Ball bearing
Technical features	<ul style="list-style-type: none"> - Output 10 VDC, max. 10 mA - Power limiter - Motor current limitation - Soft start - Control input 0-10 VDC / PWM - Control interface with SELV potential safely disconnected from the mains - Overvoltage detection - Thermal overload protection for electronics/motor - Line undervoltage detection
EMC immunity to interference	According to EN 61000-6-2 (industrial environment)
EMC interference emission	According to EN 61000-6-4 (industrial environment)
Touch current according to IEC 60990 (measuring circuit Fig. 4, TN system)	<= 3.5 mA
Motor protection	Electronic motor protection
With cable	Variable
Protection class	I (with customer connection of protective earth)
Conformity with standards	EN 60335-1; CE
Approval	C22.2 No.77 + CAN/CSA-E60730-1; UL 1004-7 + 60730; CCC

Product drawing

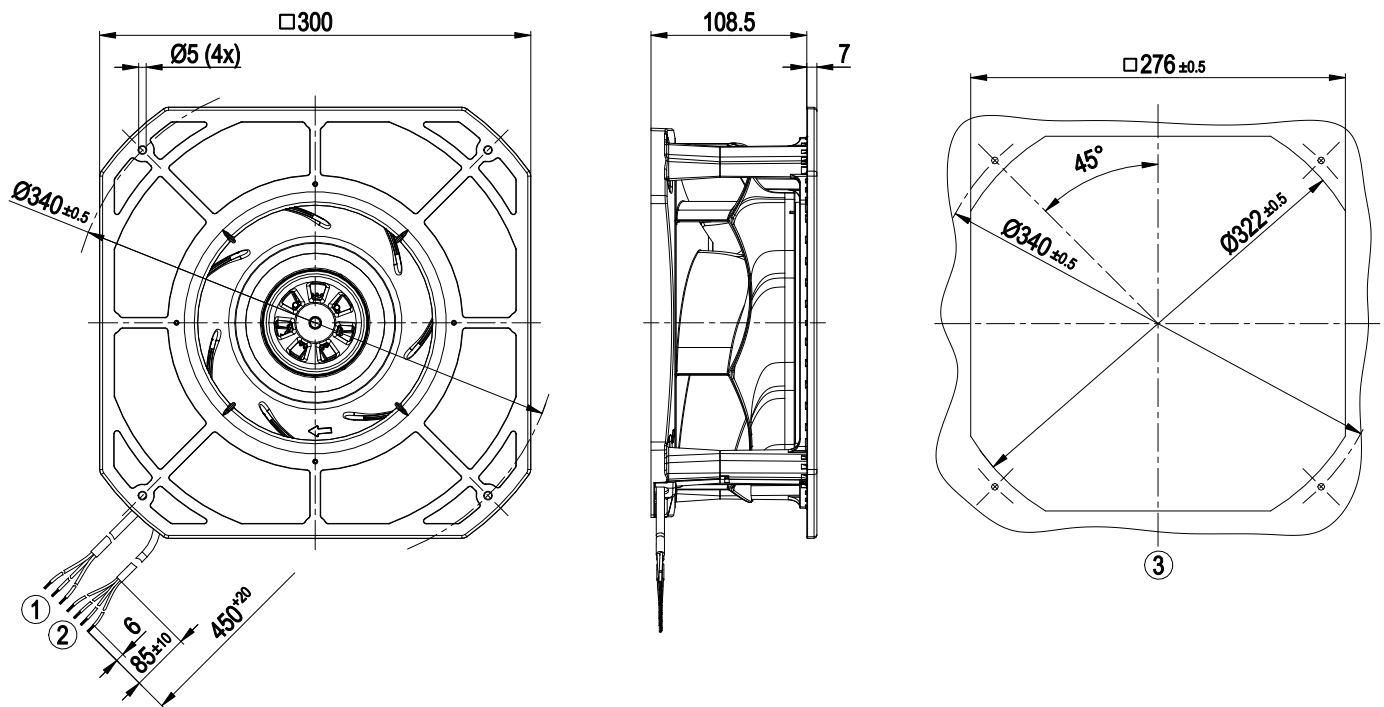

1	Cable PVC AWG20, 3x crimped splices
2	Cable PVC AWG22, 4x crimped splices
3	Mounting dimensions

EC centrifugal module - RadiCal

backward-curved, single-intake
with housing

Connection diagram

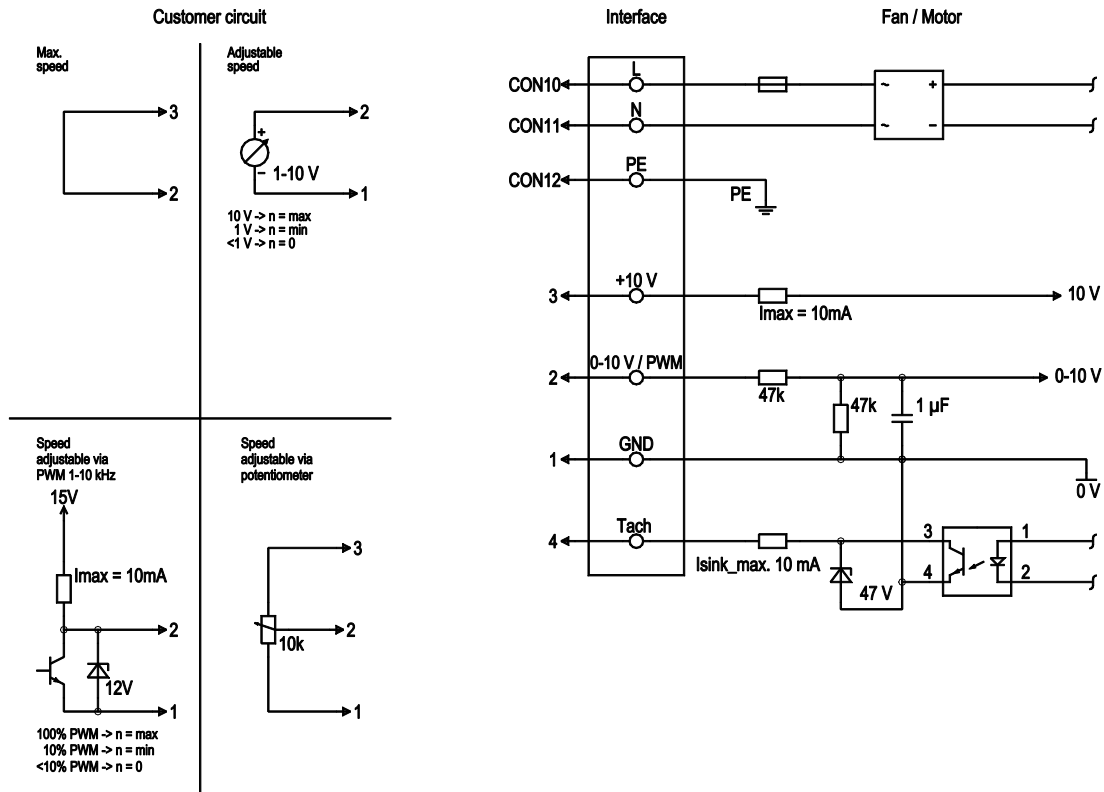

No.	Conn.	Designation	Color	Function/assignment
	CON10	L	black	Supply connection, power supply, phase, see nameplate for voltage range
	CON11	N	blue	Supply connection, power supply, neutral conductor, see nameplate for voltage range
	CON12	PE	green/yellow	Ground connection
	2	0- 10V PWM	yellow	0-10 V / PWM control input, R _i =100 kΩ, SELV
	4	Tach	white	Tach output, open collector, 1 pulse per revolution, I _{sink max} = 10 mA, SELV
	3	+10 V	red	Fixed voltage output 10 VDC +/-3 %, I _{max} . 10 mA, short-circuit-proof, power supply for ext. devices (e.g. pot), SELV
	1	GND	blue	Reference ground for control interface, SELV



Curves: Air performance 50 Hz

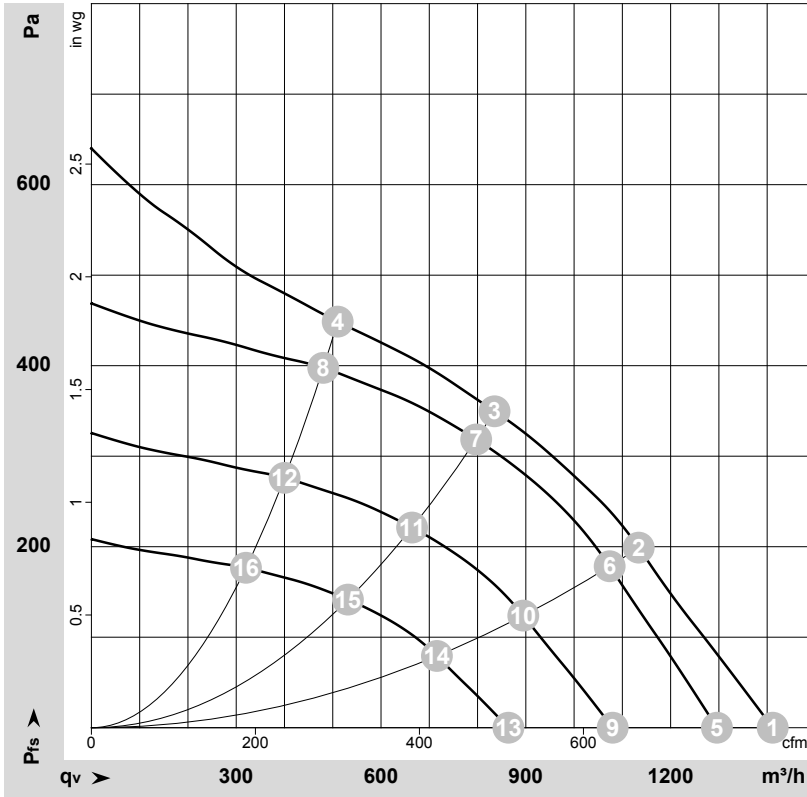

$\rho = 1.15 \text{ kg/m}^3 \pm 2 \%$

Measurement: LU-142364-1

Air performance measured according to ISO 5801 installation category A. For detailed information on the measurement setup, contact ebmpapst. Intake sound level: Sound power level according to ISO 13347 / sound pressure level measured at 1 m distance from fan axis. The values given are valid under the specified measuring conditions and may vary due to conditions of installation. For deviations from the standard configuration, the parameters have to be checked on the installed unit.

Measured values

	U	f	n	P _{ed}	I	q _v	P _{fs}	q _v	P _{fs}
	V	Hz	min ⁻¹	W	A	m ³ /h	Pa	cfm	in. wg
1	115	50	2615	135	2.00	1410	0	830	0.00
2	115	50	2535	155	2.20	1135	200	665	0.80
3	115	50	2500	163	2.30	835	350	490	1.41
4	115	50	2545	148	2.00	510	450	300	1.81
5	115	50	2400	104	1.36	1295	0	765	0.00
6	115	50	2400	131	1.71	1075	179	630	0.72
7	115	50	2400	140	1.80	795	319	470	1.28
8	115	50	2400	124	1.62	480	398	285	1.60
9	115	50	2000	60	0.79	1080	0	635	0.00
10	115	50	2000	76	0.99	895	124	525	0.50
11	115	50	2000	81	1.04	665	221	390	0.89
12	115	50	2000	72	0.94	400	277	235	1.11
13	115	50	1600	31	0.40	865	0	510	0.00
14	115	50	1600	39	0.51	715	79	420	0.32
15	115	50	1600	41	0.53	530	142	315	0.57
16	115	50	1600	37	0.48	320	177	190	0.71

U = Power supply · f = Frequency · n = Speed (rpm) · P_{ed} = Power consumption · I = Current draw · q_v = Air flow · p_{fs} = Pressure increase