

## ASIA PACIFIC SHENGRUI LIMITED

Phone +00852 56261528

info@apacfan.com

www.apacfan.com

## Nominal data

Type	W2E250-HJ32-18			
Motor	M2E068-DF			
Phase		1~	1~	1~
Nominal voltage	VAC	115	115	115
Frequency	Hz	50	60	60
Method of obtaining data		fa	fa	fa
Valid for approval/standard		-	UL 1004-3	-
Speed (rpm)	min <sup>-1</sup>	2600	2850	2850
Power consumption	W	115	175	160
Current draw	A	1.02	1.47	1.42
Capacitor	μF	12	12	12
Capacitor voltage	VDB	220	220	220
Capacitor standard		S0 (CE)	UL	S0 (CE)
Max. back pressure	Pa	150	120	120
Max. back pressure	in. wg	0.6	0.48	0.48
Min. ambient temperature	°C	-25	-25	-25
Max. ambient temperature	°C	70	55	55
Starting current	A	2	2.1	2.1

ml = Max. load · me = Max. efficiency · fa = Free air · cs = Customer specification · ce = Customer equipment  
Subject to change



## Technical description

Weight	3.6 kg
Size	250 mm
Motor size	68
Rotor surface	Painted black
Blade material	Sheet steel, galvanized
Fan housing material	Sheet steel, galvanized
Guard grille material	Steel, coated with white-aluminum plastic (RAL 9006)
Number of blades	7
Airflow direction	V
Direction of rotation	Counterclockwise, viewed toward rotor
Degree of protection	IP44; installation- and position-dependent
Insulation class	"B"
Moisture (F) / Environmental (H) protection class	H1
Max. permitted ambient temp. for motor (transport/storage)	+80 °C
Min. permitted ambient temp. for motor (transport/storage)	-40 °C
Installation position	Any
Condensation drainage holes	None
Mode	S1
Motor bearing	Ball bearing
Touch current according to IEC 60990 (measuring circuit Fig. 4, TN system)	< 0.75 mA
Electrical hookup	Terminal strip; Capacitor connected
Motor protection	Thermal overload protector (TOP) internally connected
With cable	Variable
Protection class	I (with customer connection of protective earth)
Motor capacitor according to EN 60252-1 in safety protection class	S0
Conformity with standards	EN 60034-1; EN 60204-1; EN 60335-1
Comment on CE	Commissioning not permitted in the European Economic Area
Approval	CSA C22.2 No. 77; UL 1004-3

## Product drawing

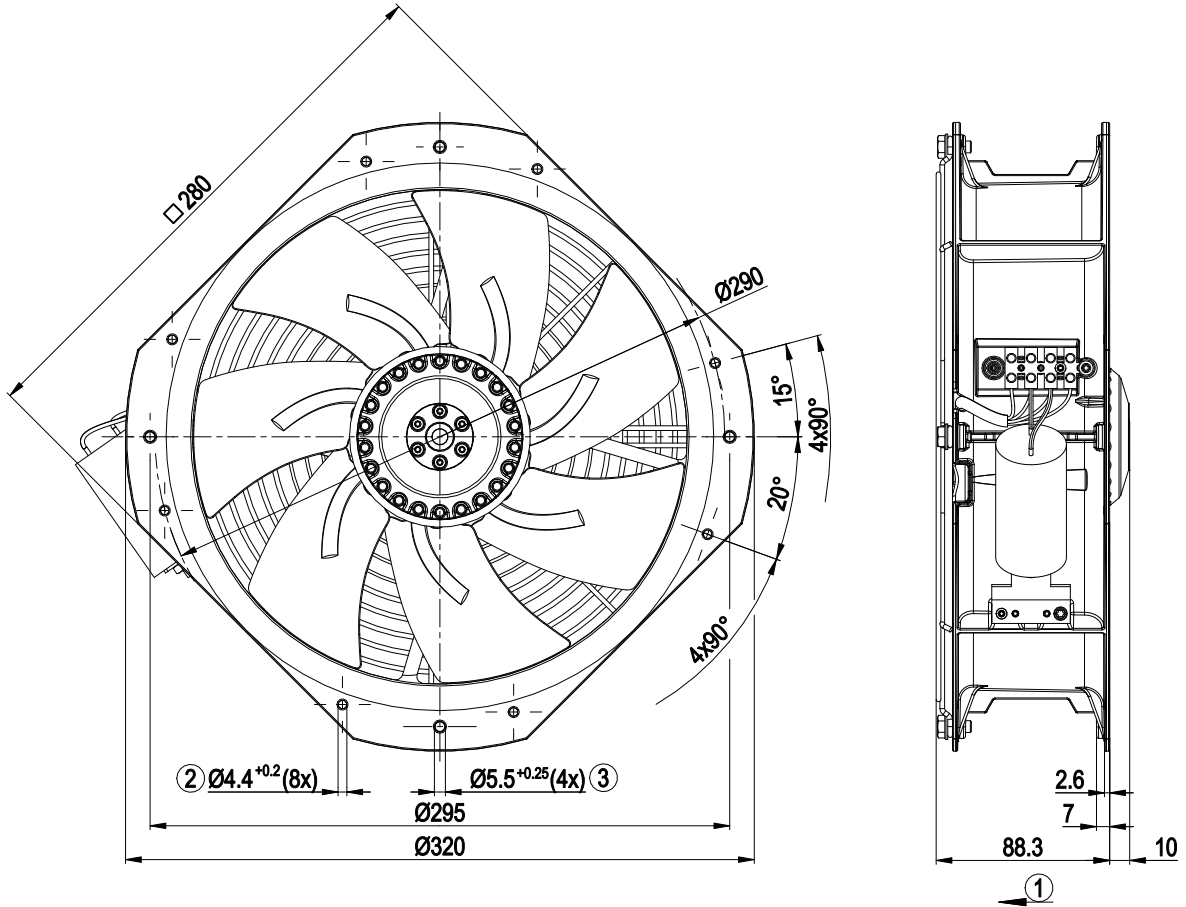

1	Airflow direction "V"
2	For self-tapping M5 screws
3	For self-tapping M6 screws

## Connection diagram

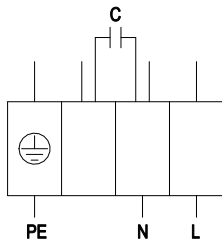

PE	green/yellow	N	black	L	blue
----	--------------	---	-------	---	------

## Curves: Air performance 50 Hz

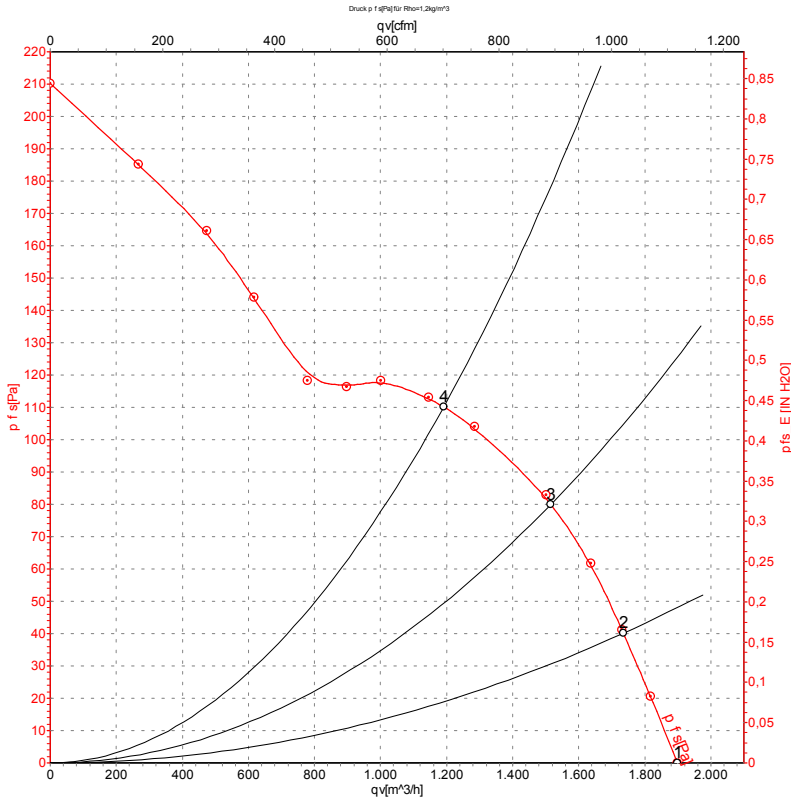

Measurement: LU-29333-1

Air performance measured according to ISO 5801 installation category A. For detailed information on the measurement setup, contact ebm-papst. Intake sound level: Sound power level according to ISO 13347 / sound pressure level measured at 1 m distance from fan axis. The values given are valid under the specified measuring conditions and may vary due to conditions of installation. For deviations from the standard configuration, the parameters have to be checked on the installed unit.

## Measured values

	U	f	n	P <sub>e</sub>	I	q <sub>v</sub>	p <sub>fs</sub>	q <sub>v</sub>	p <sub>fs</sub>
	V	Hz	min <sup>-1</sup>	W	A	m³/h	Pa	cfm	in. wg
1	115	50	2600	115	1.02	1900	0	1120	0.00
2	115	50	2570	128	1.12	1735	40	1020	0.16
3	115	50	2505	137	1.20	1515	80	890	0.32
4	115	50	2435	147	1.29	1190	110	700	0.44

U = Voltage · f = Frequency · n = Speed (rpm) · P<sub>e</sub> = Power consumption · I = Current draw · q<sub>v</sub> = Air flow · p<sub>fs</sub> = Pressure increase



## Curves: Air performance 60 Hz

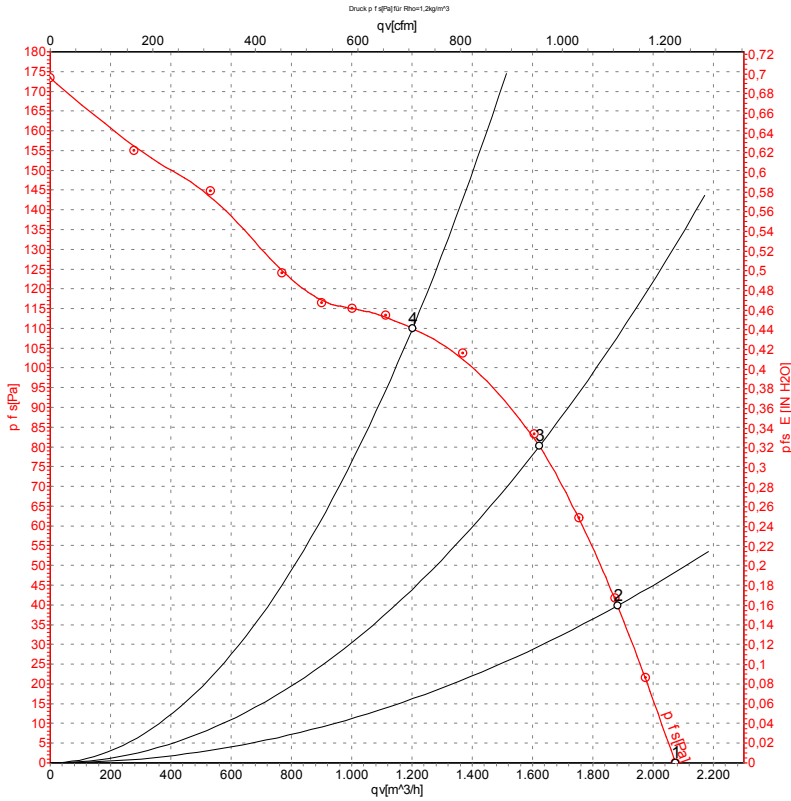

Measurement: LU-29334-1

Air performance measured according to ISO 5801 installation category A. For detailed information on the measurement setup, contact ebm-papst. Intake sound level: Sound power level according to ISO 13347 / sound pressure level measured at 1 m distance from fan axis. The values given are valid under the specified measuring conditions and may vary due to conditions of installation. For deviations from the standard configuration, the parameters have to be checked on the installed unit.

## Measured values

	U	f	n	P <sub>e</sub>	I	q <sub>V</sub>	P <sub>fs</sub>	q <sub>V</sub>	P <sub>fs</sub>
	V	Hz	min <sup>-1</sup>	W	A	m³/h	Pa	cfm	in. wg
1	115	60	2850	160	1.42	2075	0	1220	0.00
2	115	60	2760	178	1.53	1880	40	1105	0.16
3	115	60	2620	185	1.60	1620	80	955	0.32
4	115	60	2445	194	1.68	1200	110	705	0.44

U = Voltage · f = Frequency · n = Speed (rpm) · P<sub>e</sub> = Power consumption · I = Current draw · q<sub>V</sub> = Air flow · P<sub>fs</sub> = Pressure increase

