

AC axial fan - HyBlade

sickle-shaped blades (S series)

with square full nozzle

ASIA PACIFIC SHENGRUI LIMITED

Phone +00852 56261528

info@apacfan.com

www.apacfan.com

Nominal data

Type	W6D710-DH01-07				
Motor	M6D138-HF				
Phase		3~	3~	3~	3~
Nominal voltage	VAC	400	400	480	480
Wiring		Δ	Y	Δ	Y
Frequency	Hz	50	50	60	60
Method of obtaining data		ml	ml	ml	ml
Valid for approval/standard		CE	CE	CE	CE
Speed (rpm)	min ⁻¹	905	730	1060	780
Power consumption	W	1030	690	1700	1030
Current draw	A	2.35	1.34	2.87	1.72
Max. back pressure	Pa	125	80	170	92
Max. back pressure	in. wg	0.5	0.32	0.68	0.37
Min. ambient temperature	°C	-40	-40	-40	-40
Max. ambient temperature	°C	80	80	60	60
Starting current	A	9	3	10	3.5

ml = Max. load · me = Max. efficiency · fa = Free air · cs = Customer specification · ce = Customer equipment
Subject to change

Data according to Commission Regulation (EU) 327/2011 (EN 17166)

		Actual	Req. 2015		
01 Overall efficiency η_{es}	%	33.9	33.6	09 Power consumption P_e	kW 0.98
02 Measurement category	A			09 Air flow q_v	m ³ /h 11515
03 Efficiency category	Static			09 Pressure increase p_{fs}	Pa 112
04 Efficiency grade N	40.3	40		10 Speed (rpm) n	min ⁻¹ 915
05 Variable speed drive	No			11 Specific ratio*	1.00

Data obtained at optimum efficiency level.
The ErP data is determined using a motor-impeller combination in a standardized measurement setup.

* Specific ratio = $1 + p_{fs} / 100\,000\text{ Pa}$

LU-199790



AC axial fan - HyBlade

sickle-shaped blades (S series)

with square full nozzle

Technical description

Weight	40.1 kg
Size	710 mm
Motor size	138
Rotor surface	Cast in aluminum
Terminal box material	Die-cast aluminum
Blade material	Sheet aluminum insert, sprayed with PP plastic
Fan housing material	Sheet steel, galvanized and coated with black plastic (RAL 9005)
Guard grille material	Steel, coated with black plastic (RAL 9005)
Number of blades	5
Blade pitch	-5°
Airflow direction	A
Direction of rotation	Counterclockwise, viewed toward rotor
Degree of protection	IP54
Insulation class	"F"
Moisture (F) / Environmental (H) protection class	H2
Ambient temperature note	Occasional start-up at temperatures between -40°C and -25°C is permitted. For continuous operation at ambient temperatures below -25°C (such as refrigeration applications), use must be made of a fan design with special low-temperature bearings.
Max. permitted ambient temp. for motor (transport/storage)	+ 80 °C
Min. permitted ambient temp. for motor (transport/storage)	- 40 °C
Installation position	Any
Condensation drainage holes	On rotor and stator sides
Mode	S1
Motor bearing	Ball bearing
Touch current according to IEC 60990 (measuring circuit Fig. 4, TN system)	≤ 3.5 mA
Electrical hookup	Terminal box
Motor protection	Thermal overload protector (TOP) with basic insulation
With cable	Axial
Protection class	I (with customer connection of protective earth)
Conformity with standards	EN 60034-1 (2010); CE
Approval	VDE; EAC



AC axial fan - HyBlade

sickle-shaped blades (S series)

with square full nozzle

Product drawing

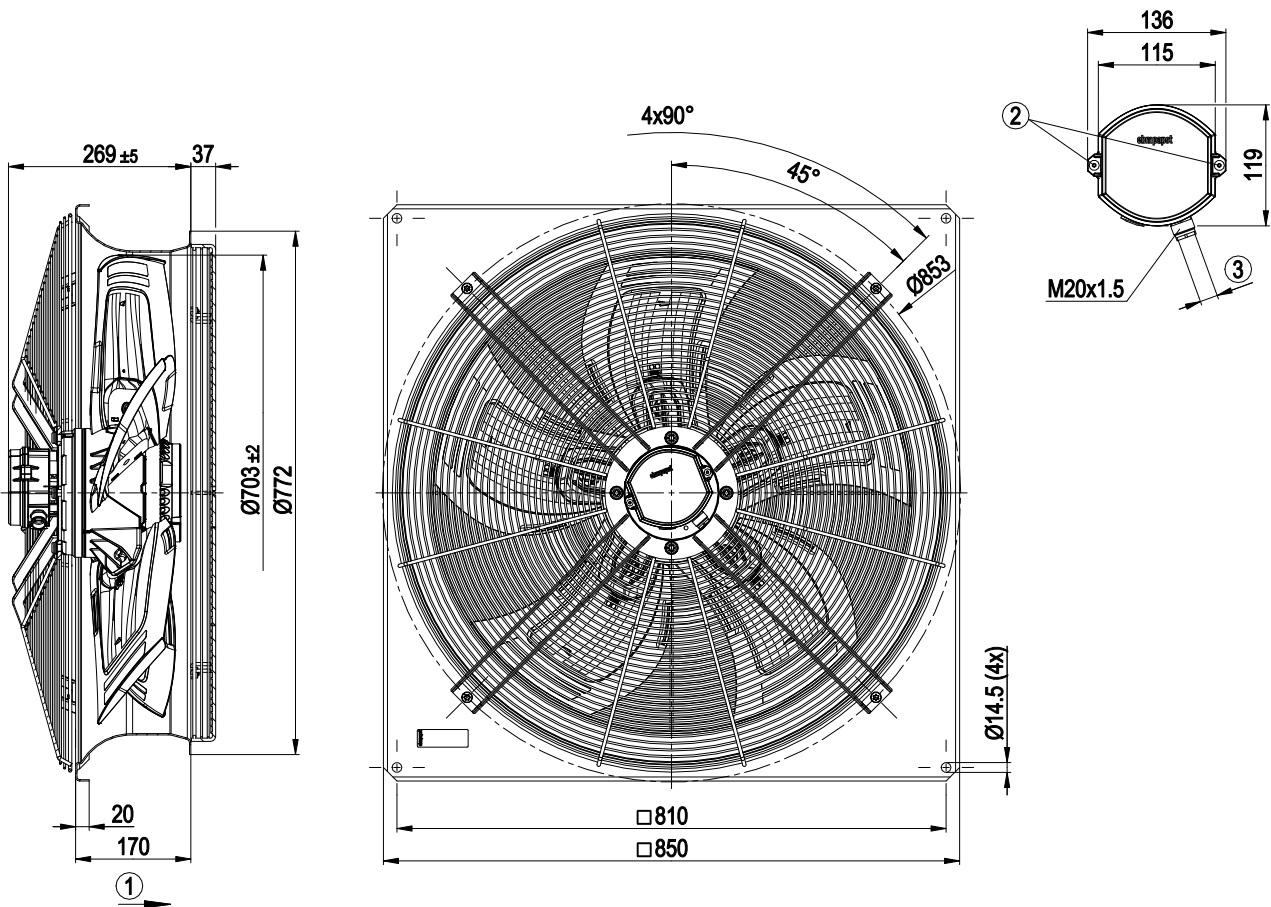

1	Direction of air flow "A"
2	Tightening torque 2.5 ± 0.4 Nm
3	Cable diameter: min. 7 mm, max. 14 mm; tightening torque 2.0 ± 0.3 Nm

AC axial fan - HyBlade

sickle-shaped blades (S series)

with square full nozzle

Connection diagram

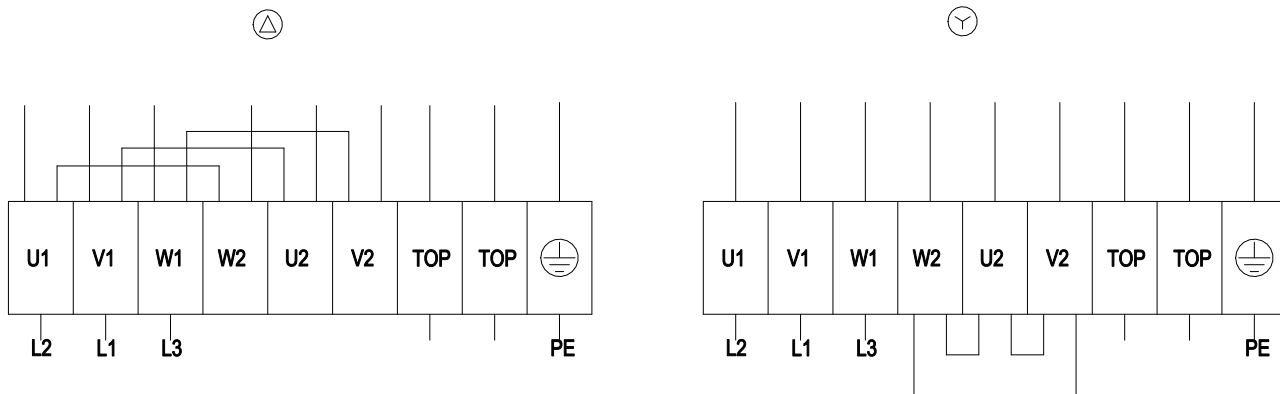

Δ	Delta connection	Y	Star connection	L1	= V1 = blue
L2	= U1 = black	L3	= W1 = brown	W2	yellow
U2	green	V2	white	TOP	2x gray
PE	green/yellow				

AC axial fan - HyBlade

sickle-shaped blades (S series)

with square full nozzle

Curves: Air performance 50 Hz

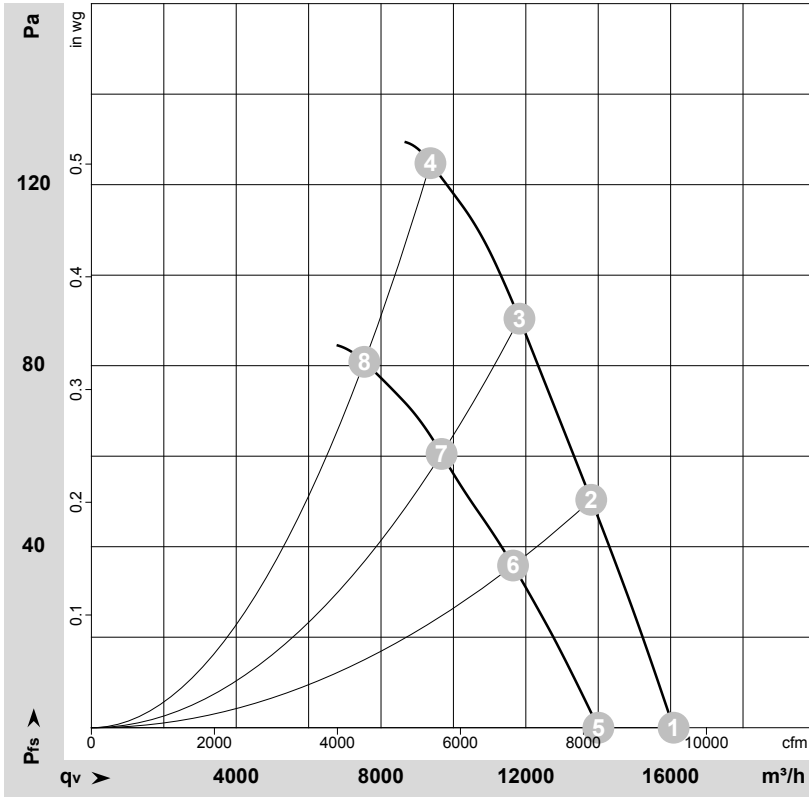

$\rho = 1.15 \text{ kg/m}^3 \pm 2 \%$

Measurement: LU-113715-1
Measurement: LU-113738-1

Air performance measured according to ISO 5801 installation category A. For detailed information on the measurement setup, contact ebm-papst. Intake sound level: Sound power level according to ISO 13347 / sound pressure level measured at 1 m distance from fan axis. The values given are valid under the specified measuring conditions and may vary due to conditions of installation. For deviations from the standard configuration, the parameters have to be checked on the installed unit.

Measured values

	Wired	U	f	n	P _e	I	LpA _{in}	LwA _{in}	LwA _{out}	q _v	p _{fs}	q _v	p _{fs}
		V	Hz	min ⁻¹	W	A	dB(A)	dB(A)	dB(A)	m ³ /h	Pa	cfm	in. wg
1	Δ	400	50	940	725	2.07	64	71	70	16080	0	9465	0.00
2	Δ	400	50	925	866	2.19	62	69	69	13805	50	8125	0.20
3	Δ	400	50	915	947	2.27	64	70	69	11825	90	6960	0.36
4	Δ	400	50	905	1030	2.35	68	75	74	9365	125	5510	0.50
5	Y	400	50	820	542	1.05	61	67	67	14005	0	8245	0.00
6	Y	400	50	780	620	1.19	58	65	64	11650	36	6855	0.14
7	Y	400	50	755	661	1.27	59	65	64	9675	60	5695	0.24
8	Y	400	50	730	690	1.34	62	69	68	7540	81	4435	0.33

Wired = Wiring · U = Voltage · f = Frequency · n = Speed (rpm) · P_e = Power consumption · I = Current draw · LpA_{in} = Sound pressure level intake side · LwA_{in} = Sound power level intake side
LwA_{out} = Sound power level outlet side · q_v = Air flow · p_{fs} = Pressure increase



AC axial fan - HyBlade

sickle-shaped blades (S series)

with square full nozzle

Curves: Air performance 60 Hz

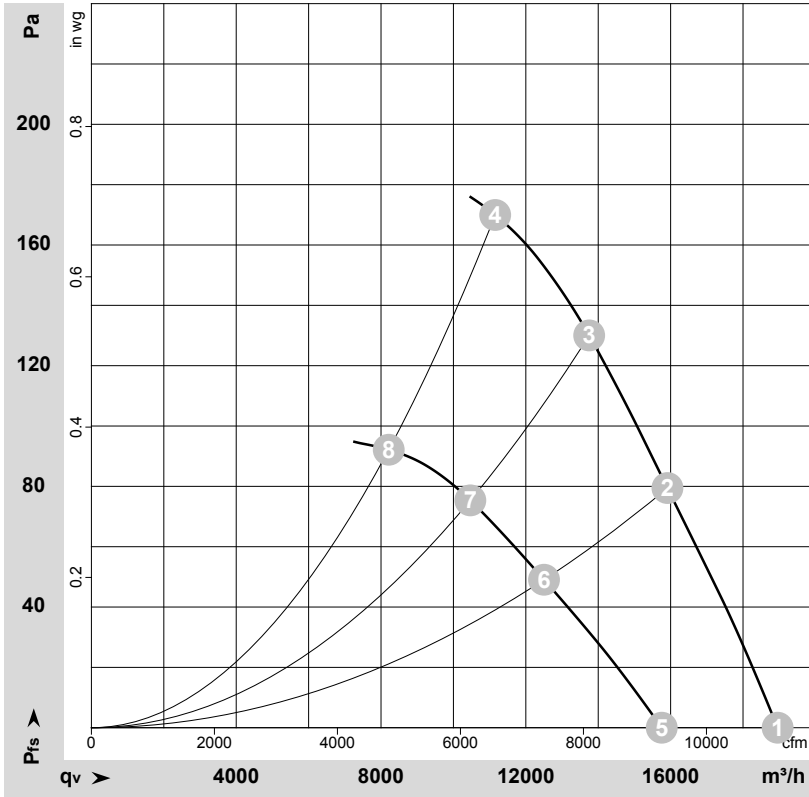

$\rho = 1.15 \text{ kg/m}^3 \pm 2 \%$

Measurement: LU-121540-1
Measurement: LU-121544-1

Air performance measured according to ISO 5801 installation category A. For detailed information on the measurement setup, contact ebm-papst. Intake sound level: Sound power level according to ISO 13347 / sound pressure level measured at 1 m distance from fan axis. The values given are valid under the specified measuring conditions and may vary due to conditions of installation. For deviations from the standard configuration, the parameters have to be checked on the installed unit.

Measured values

	Wired	U	f	n	P _e	I	LpA _{in}	LwA _{in}	LwA _{out}	q _v	p _{fs}	q _v	p _{fs}
		V	Hz	min ⁻¹	W	A	dB(A)	dB(A)	dB(A)	m ³ /h	Pa	cfm	in. wg
1	Δ	480	60	1115	1191	2.37	67	74	74	18955	0	11155	0.00
2	Δ	480	60	1085	1444	2.60	66	73	73	15910	80	9365	0.32
3	Δ	480	60	1075	1563	2.71	68	75	74	13750	130	8095	0.52
4	Δ	480	60	1060	1700	2.87	72	79	78	11155	170	6565	0.68
5	Y	480	60	930	853	1.37	63	70	69	15755	0	9275	0.00
6	Y	480	60	855	959	1.57	60	67	66	12505	49	7360	0.20
7	Y	480	60	820	996	1.65	61	67	66	10465	75	6160	0.30
8	Y	480	60	780	1030	1.72	64	70	70	8215	93	4835	0.37

Wired = Wiring · U = Voltage · f = Frequency · n = Speed (rpm) · P_e = Power consumption · I = Current draw · LpA_{in} = Sound pressure level intake side · LwA_{in} = Sound power level intake side
LwA_{out} = Sound power level outlet side · q_v = Air flow · p_{fs} = Pressure increase

