

ASIA PACIFIC SHENGRUI LIMITED

Phone +00852 56261528

info@apacfan.com

www.apacfan.com

Nominal data

Type	R2D225-RA26-23				
Motor	M2D068-DF				
Phase		3~	3~	3~	3~
Nominal voltage	VAC	400	400	415	415
Wiring		Y	Y	Y	Y
Frequency	Hz	50	60	50	60
Method of obtaining data		ml	ml	ml	ml
Valid for approval/standard		CE	CE	CE	CE
Speed (rpm)	min ⁻¹	2530	2700	2550	2720
Power consumption	W	150	200	155	210
Current draw	A	0.27	0.33	0.28	0.35
Min. back pressure	Pa	0	0	0	0
Min. back pressure	in. wg	0	0	0	0
Min. ambient temperature	°C	-25	-25	-25	-25
Max. ambient temperature	°C	80	55	80	55
Starting current	A	0.74	0.72		

ml = Max. load · me = Max. efficiency · fa = Free air · cs = Customer specification · ce = Customer equipment
Subject to change

Data according to Commission Regulation (EU) 327/2011 (EN 17166)

		Actual	Req. 2015			
01 Overall efficiency η_{es}	%	43.6	42.6	09 Power consumption P_e	kW	0.14
02 Measurement category		A		09 Air flow q_v	m ³ /h	705
03 Efficiency category		Static		09 Pressure increase p_{fs}	Pa	318
04 Efficiency grade N		63	62	10 Speed (rpm) n	min ⁻¹	2555
05 Variable speed drive		No		11 Specific ratio*		1.00

Data obtained at optimum efficiency level.
The ErP data is determined using a motor-impeller combination in a standardized measurement setup.

* Specific ratio = $1 + p_{fs} / 100\,000\text{ Pa}$

LU-140430



Technical description

Weight	2.17 kg
Size	225 mm
Motor size	68
Rotor surface	Painted black
Impeller material	PA plastic
Number of blades	7
Direction of rotation	Clockwise, viewed toward rotor
Degree of protection	IP44; installation- and position-dependent
Insulation class	"F"
Moisture (F) / Environmental (H) protection class	H1+
Max. permitted ambient temp. for motor (transport/storage)	+ 80 °C
Min. permitted ambient temp. for motor (transport/storage)	- 40 °C
Installation position	Any
Condensation drainage holes	None
Mode	S1
Motor bearing	Ball bearing
Touch current according to IEC 60990 (measuring circuit Fig. 4, TN system)	< 0.75 mA
Electrical hookup	Connector with cable
Motor protection	Thermal overload protector (TOP) with basic insulation
With cable	Lateral
Protection class	I (with customer connection of protective earth)
Conformity with standards	EN 60335-1; CE
Approval	UL 1004-1; CSA C22.2 No. 100

Product drawing

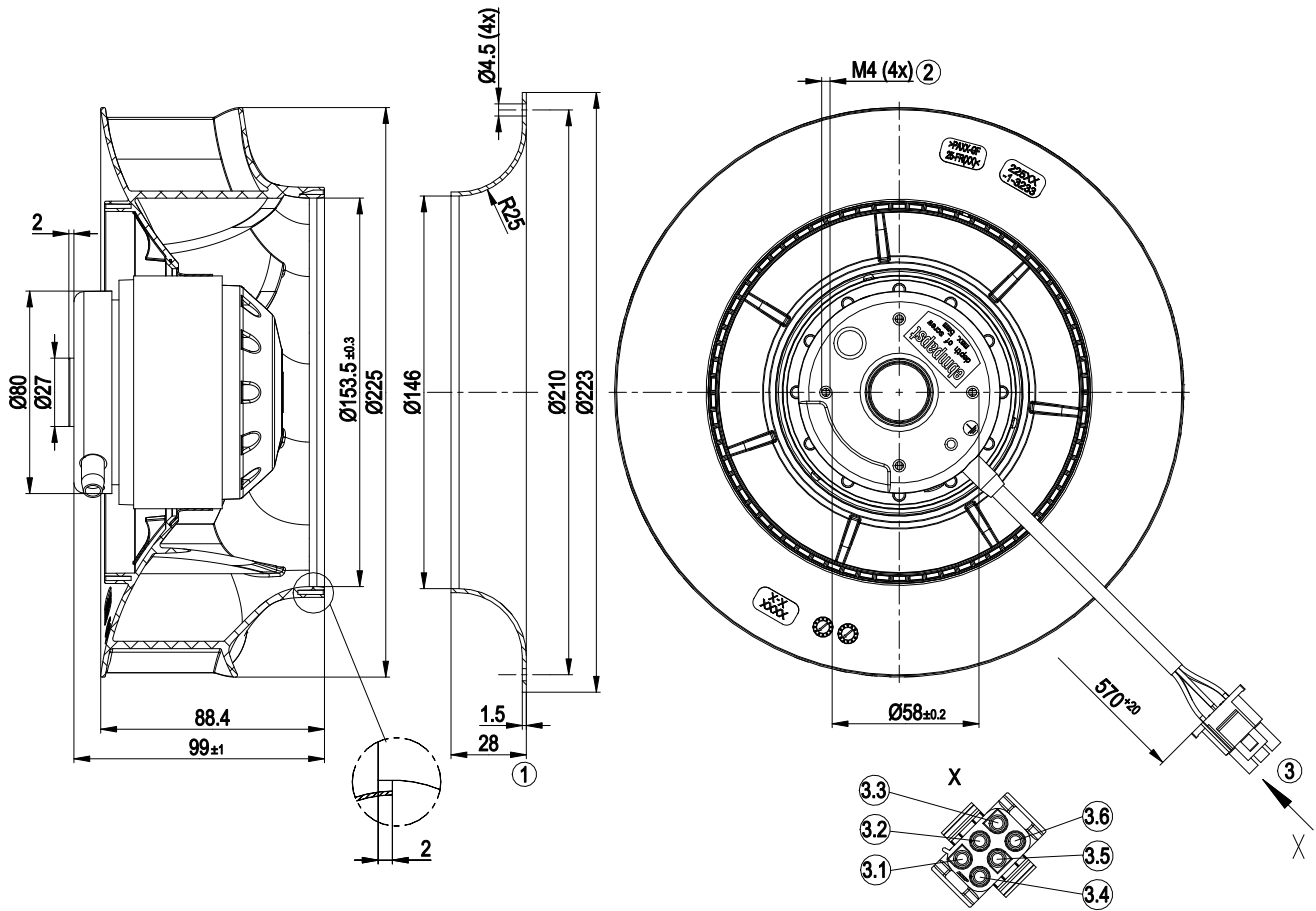

1	Accessory part: inlet ring 96358-2-4013 not included in scope of delivery
2	Max. clearance for screw 5 mm
3	Cable PFA AWG20 (green/yellow AWG18), 6-pole connector housing tyco 1586846-1, 6x plug pin tyco 926885-1
3.1	black
3.2	blue
3.3	brown
3.4	green/yellow
3.5	gray (TOP)
3.6	gray (TOP)

Connection diagram

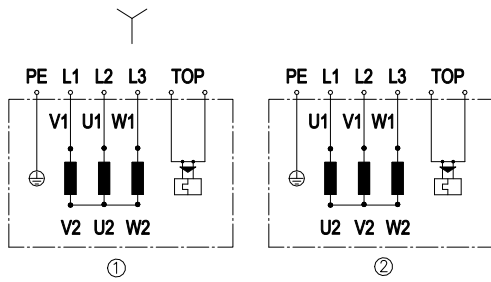

Change of rotation direction by reversing two phases

	Three-phase motor
Y	Star connection
1	Counterclockwise operation
L1	= V1 = blue
L2	= U1 = black
L3	= W1 = brown
2	Clockwise operation
L1	= U1 = black
L2	= V1 = blue
L3	= W1 = brown
PE	green/yellow
TOP	2x gray

Curves: Air performance 50 Hz

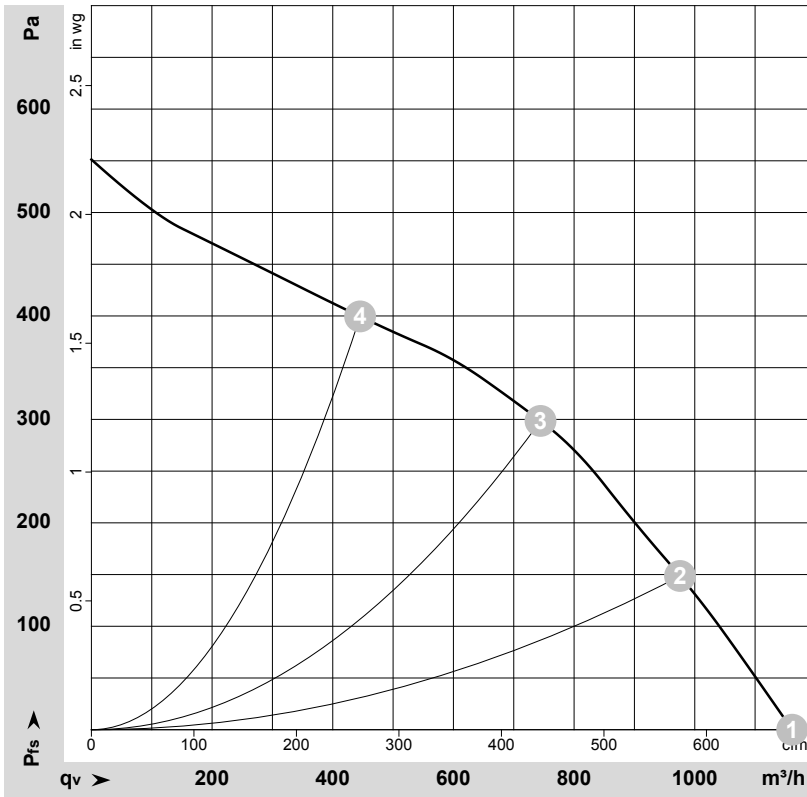

$\rho = 1.15 \text{ kg/m}^3 \pm 2 \%$

Measurement: LU-140430-1

Air performance measured according to ISO 5801 installation category A. For detailed information on the measurement setup, contact ebmpapst. Intake sound level: Sound power level according to ISO 13347 / sound pressure level measured at 1 m distance from fan axis. The values given are valid under the specified measuring conditions and may vary due to conditions of installation. For deviations from the standard configuration, the parameters have to be checked on the installed unit.

Measured values

	Wired	U	f	n	P_e	I	LpA_{in}	LwA_{in}	q_v	P_{fs}	q_v	P_{fs}
		V	Hz	min^{-1}	W	A	dB(A)	dB(A)	m^3/h	Pa	cfm	in. wg
1	Y	400	50	2645	122	0.24	66	74	1160	0	685	0.00
2	Y	400	50	2560	142	0.26	62	69	975	150	575	0.60
3	Y	400	50	2530	150	0.27	57	65	745	300	440	1.20
4	Y	400	50	2595	130	0.24	61	69	445	400	260	1.61

Wired = Wiring · U = Voltage · f = Frequency · n = Speed (rpm) · P_e = Power consumption · I = Current draw · LpA_{in} = Sound pressure level intake side · LwA_{in} = Sound power level intake side
 q_v = Air flow · P_{fs} = Pressure increase

Curves: Air performance 60 Hz

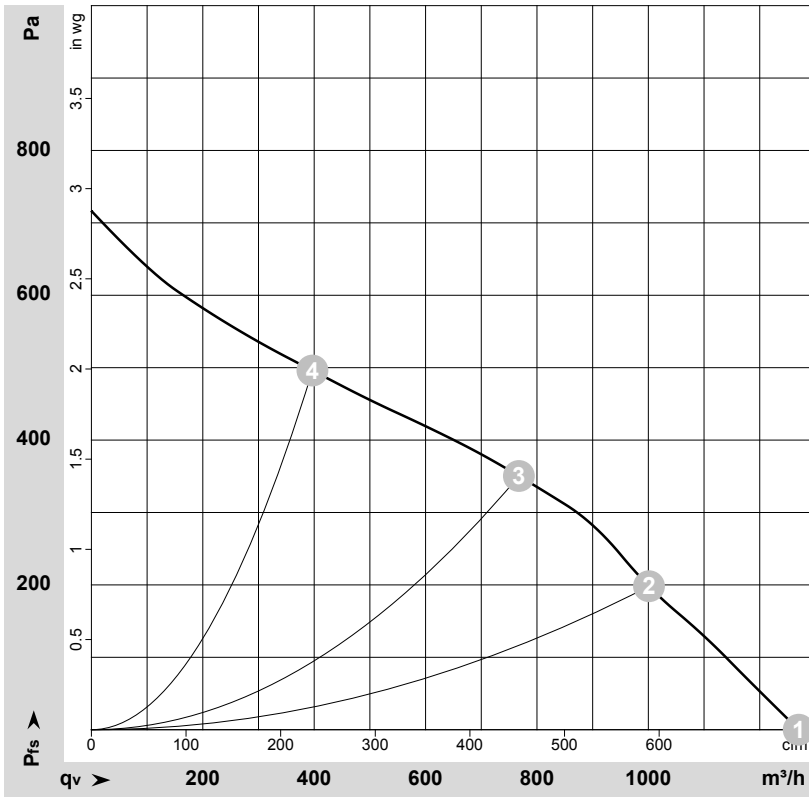

$\rho = 1.15 \text{ kg/m}^3 \pm 2 \%$

Measurement: LU-140433-1

Air performance measured according to ISO 5801 installation category A. For detailed information on the measurement setup, contact ebm-papst. Intake sound level: Sound power level according to ISO 13347 / sound pressure level measured at 1 m distance from fan axis. The values given are valid under the specified measuring conditions and may vary due to conditions of installation. For deviations from the standard configuration, the parameters have to be checked on the installed unit.

Measured values

	Wired	U	f	n	Pe	I	qv	Pfs	qv	Pfs
		V	Hz	min ⁻¹	W	A	m ³ /h	Pa	cfm	in. wg
1	Y	400	60	2880	171	0.28	1270	0	745	0.00
2	Y	400	60	2700	201	0.32	1000	200	590	0.80
3	Y	400	60	2700	200	0.33	770	350	450	1.41
4	Y	400	60	2845	174	0.28	395	500	235	2.01

Wired = Wiring · U = Voltage · f = Frequency · n = Speed (rpm) · Pe = Power consumption · I = Current draw · qv = Air flow · Pfs = Pressure increase